

RENAULT

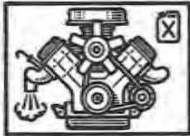

R 30

1 10 ⇨ 19



2 20 ⇨ 29

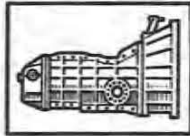

3 31 ⇨ 38

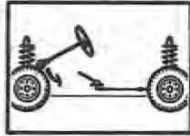

4 40 ⇨ 48

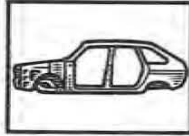

5 50 ⇨ 59



6 60 ⇨ 69

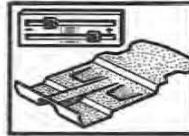

7 71 ⇨ 79

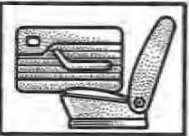

8 80 ⇨ 88



9 90 ⇨ 97

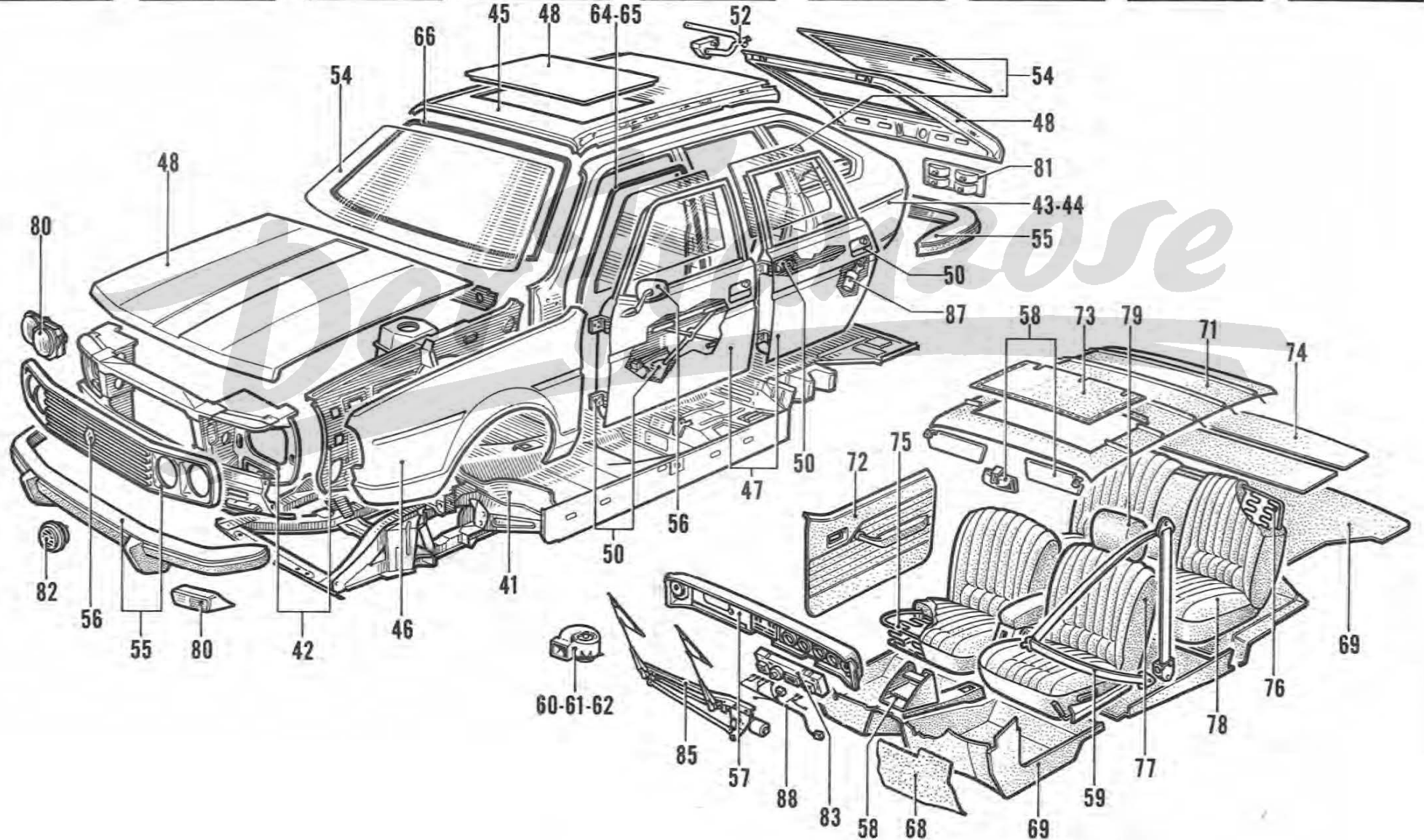
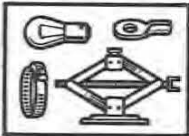

01.10

A P.R.1030

01.10

A P.R.1030

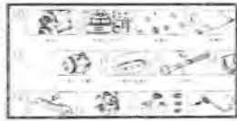

01.02 A - 01.03 A
01.10 A ⇨ 01.14 A



01.20 A

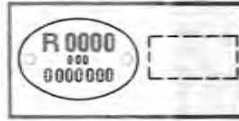

02.01 A - 02.02



03.01 ⇨ 03.04

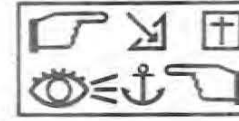

05.01 ⇨ 05.13

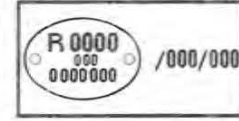

05.40 A

10



10.01 A

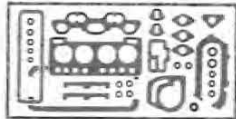

10.10 A - 10.15 A

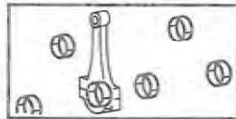

10.30 A



10.40 A

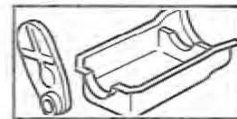

10.50 A

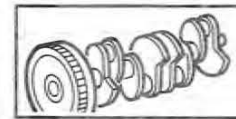

10.60 A



10.70 A

10

11

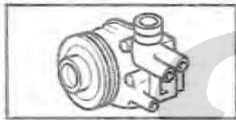

11.01 A - 12.50 A

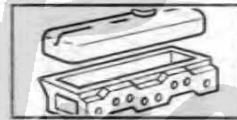

11.20 A - 11.30 A



11.40 A

11

12

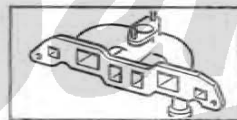

12.01 A

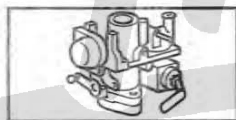

12.10 A - 12.15 A
12.45 A



12.35 A

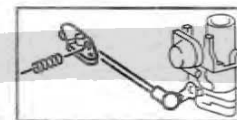

12.70 A

12

13

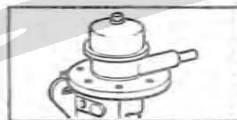

13.01 A - 13.40 A

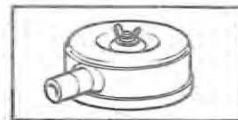

13.20 A



13.30 A

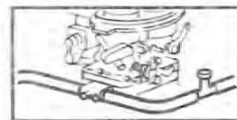

13.50 A

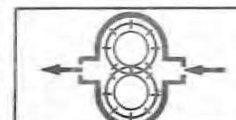

13.80 A - 13.90 A

13

16

17

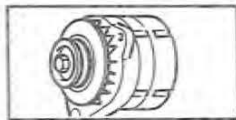

16.10 A - 16.16 A

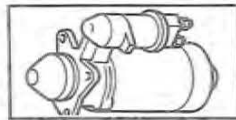

16.20 A

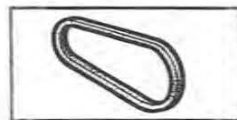

16.30 A

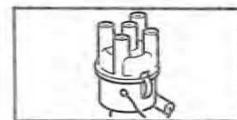

17.01 A

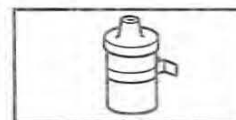

17.10 A

16

17

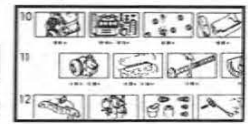

19
20

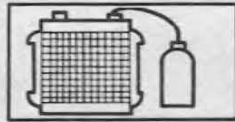

19.01 A—19.10 A



19.20 A



19.30 A

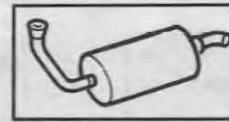

19.50 A—19.60 A



19.80 A

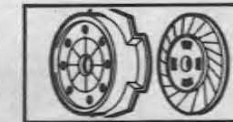

20.01 A

19
20

21



21.01 A—21.20 A
21.30 A

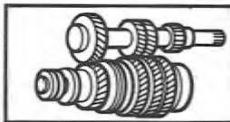

21.40 A

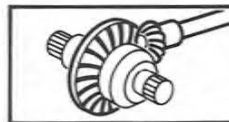

21.50 A

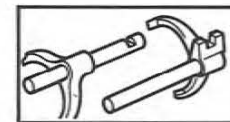

21.60 A

21

23
29



23.01 A—23.20 A
23.40 A



23.30 A

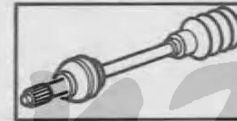

29.01 A

23
29

31
34



31.01 A—31.30 A



31.40 A



32.01 A—34.01 A



32.10 A—34.10 A

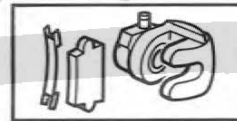

32.30 A—34.30 A



33.01 A



33.40 A

31
34

35
36



35.01 A



35.10 A

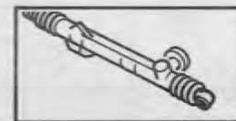

36.01 A—36.20 A
36.30 A



36.40 A

35
36

37

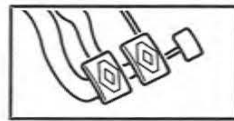

37.01 A—37.10 A
37.20 A—37.30 A

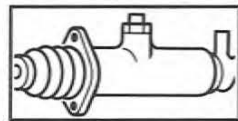

37.40 A



37.60 A

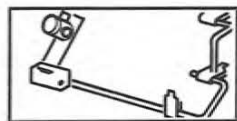

37.70 A

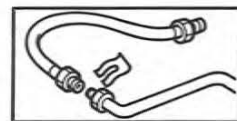

37.80 A

37

38



38.01 A



38.20 A



38.30 A

38



40
41
42

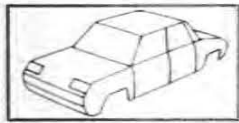

40.01 A

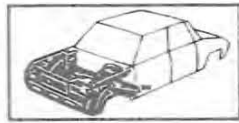

40.10 A

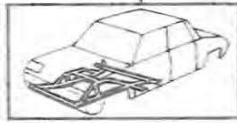

41.10 A

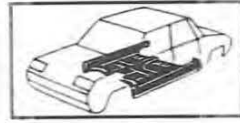

41.20 A

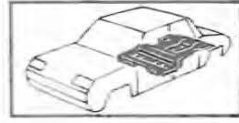

41.30 A



42.01 A



42.10 A

40
41
42

43
46

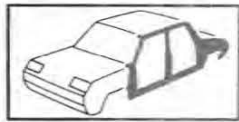

43.01 A

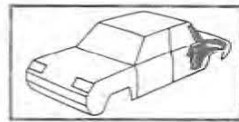

44.01 A

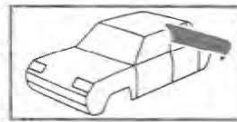

44.20 A

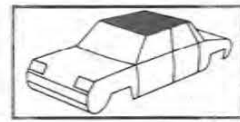

45.01 A



46.01 A

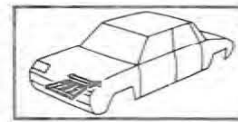

46.10 A

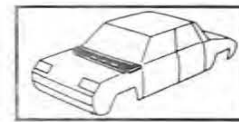

46.20 A

43
46

47
48

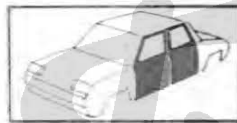

47.01 A

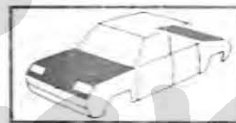

48.01 A

47
48

50
52

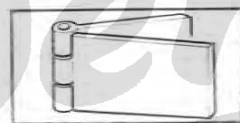

50.01 A



50.15 A - 50.25 A
52.01 A

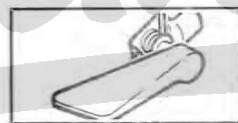

50.40 A - 50.50 A

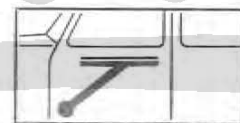

50.60 A - 50.70 A

50
52

52
53
54

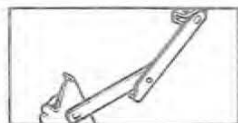

52.20 A

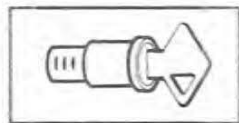

53.01 A

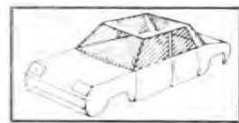

54.01 A

52
53
54

55
56

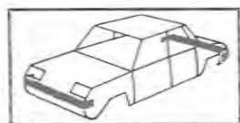

55.01 A - 55.10 A



55.20 A - 55.30 A
64.01 A



55.40 A



56.01 A



56.20 A - 58.20 A



56.40 A

55
56

57
58
59

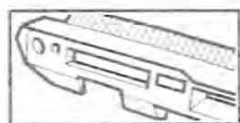

57.01 A - 57.10 A

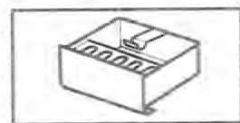

57.30 A

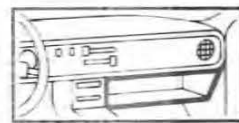

58.01 A



58.30 A

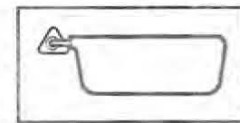

58.40 A



59.20 A

57
58
59



60
⇩
66

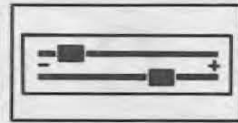

60.10 A—61.30 A



60.20 A

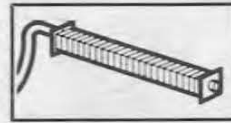

61.01 A



65.01 A—66.01 A

60
⇩
66

68
⇩
79



68.01 A—71.01 A
74.01 A

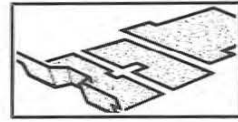

69.01 A

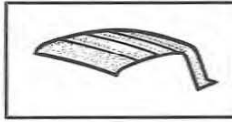

71.10 A



72.01 A



75.01 A—76.01 A



77.01 A—77.10 A—78.01 A
78.10 A—79.01 A

68
⇩
79

80
81

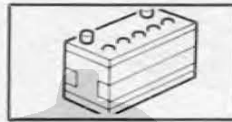

80.01 A

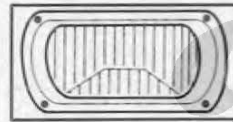

80.10 A—80.20 A

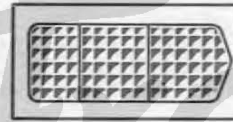

80.30 A—81.10 A



81.20 A

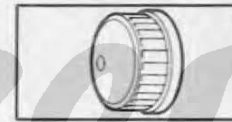

81.40 A

80
81

82
83
84



82.01 A

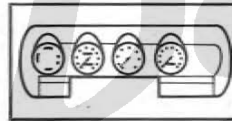

83.01 A

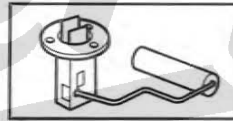

83.10 A



84.01 A

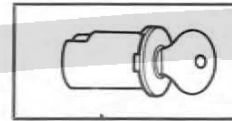

84.10 A

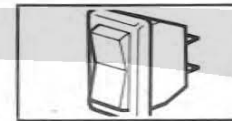

84.20 A

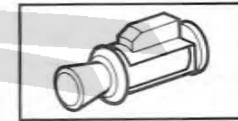

84.30 A

82
83
84

85
86
87



85.01 A—85.10 A
85.20 A

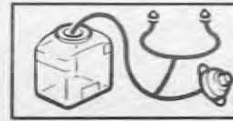

86.01 A

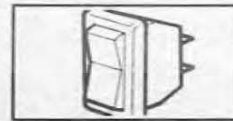

86.20 A

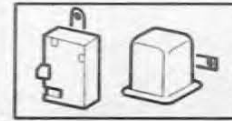

87.01 A—87.30 A

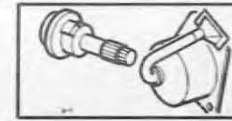

87.50 A

85
86
87

88

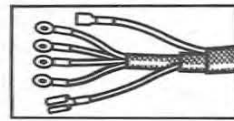

88.01 A

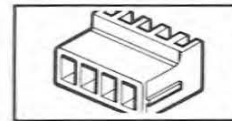

88.20 A

88

90

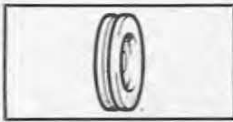

90.10 B—90.15 B



90.20 B—90.25 C



90.30 C

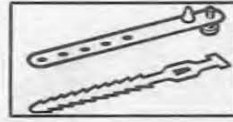

90.35 B



90.40 A



90.50 A—90.55 B

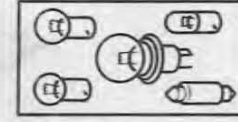

90.60 A

90

01.14

A PR 1030

01.14

A PR 1030



94
↓
130

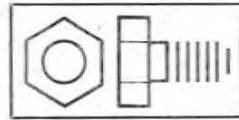

94.01 A

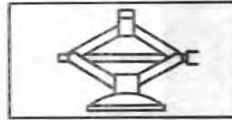

97.01 A

8023100252	5201	04	80240
8023100257	5202	04	80240
8023100302	1430	04	80240
8023100302	1430	10	80240
8023100302	1470	02	80240
8023100302	1675	02	80240
8023100302	1805	10	80240
8023100302	1810	02	80240

120



130.50

94
↓
130

Der Franzose

01.20
A P.R.1030

P.R.000
R0000-R0000

1	2	3	4	5	6	1975
7	8	9	10	11	12	

 **RENAULT 30**
R1273

1975

Der Franzose

P.R.1030 ①

77 01 438 103

Pièces de rechange - Reservedels

Ersatzteil - Spare parts

Piezas de repuesto - Pezzi di ricambio

Onderdelenboek - Reservdels

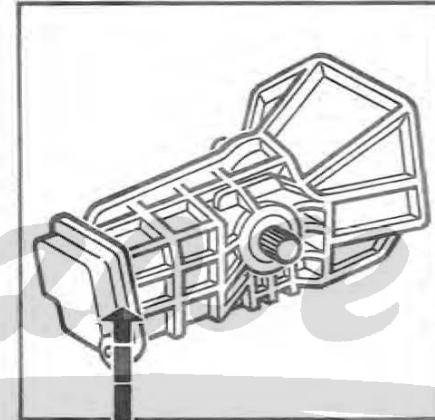
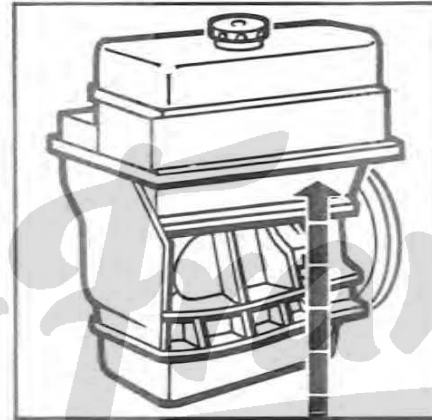
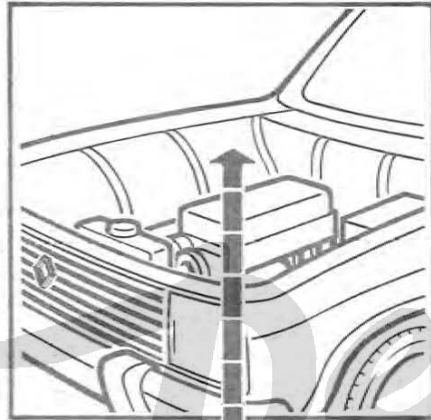
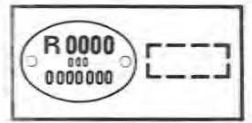

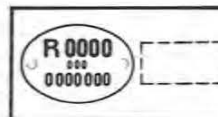

①

R 0000

②

/0...

③

n° 0...

④

n° 0...

⑤

77 03 001 022

⑥

43.30

C P.R.0..

FRANÇAIS

POUR COMMANDER DES PIÈCES DE RECHANGE, VEUILLEZ INDIQUER :

- ① Le type du véhicule
- ② Le numéro de l'équipement
- ③ Le numéro de fabrication du véhicule
- ④ Le type et le numéro de fabrication de l'organe
- ⑤ Le numéro de la pièce
- ⑥ Facultatif : le numéro du catalogue, le numéro de la planche

Si les autres N^{os} du véhicule sont détruits : le numéro dans la série du type (voir carte de garantie)

DANSK

VED BESTILLING AF RESERVEDELEBEDES DE VENLIGST OPGIVE :

- ① Vogntypen
- ② Udstyrsnummeret
- ③ Serienummeret
- ④ Fabrikationsnummeret på det samlede aggregat
- ⑤ Delnummeret
- ⑥ Undtagelsesvis Katalognummeret Planchenummeret

Hvis numrene på vognen er ødelagte, opgiv chassisnummer (se garantibeviset)

DEUTSCH

BEI DER BESTELLUNG VON ERSATZTEILEN IMMER ANGEBEN :

- ① Der Typ des Fahrzeuges
- ② Die Ausrüstungsnummer
- ③ Die Fabrikationsnummer des Fahrzeuges
- ④ Typ und Fabrikationsnummer des Aggregats
- ⑤ Die Teilnummer
- ⑥ Wenn erforderlich : Die Nummer des Kataloges, Die Nummer der Bildtafel

Wenn die anderen Fahrzeugnummern nicht mehr zu ermitteln sind : die Fahrzeugstellnummer (siehe Garantiekarte)

ENGLISH

WHEN ORDERING SPARE PARTS, WILL YOU PLEASE MENTION :

- ① The vehicle type
- ② The version number
- ③ The vehicle fabrication number
- ④ The unit type and fabrication number
- ⑤ The part number
- ⑥ And optionally : the catalogue number and page number

If the other vehicle numbers have been destroyed, the chassis number (see guarantee card)

ESPAÑOL

AL SOLICITAR PIEZAS DE REPUESTO, SIRVANSE INDICAR :

- ① El tipo del vehículo
- ② El número de su equipo
- ③ El número de fabricación del vehículo
- ④ El tipo y el número de fabricación del órgano
- ⑤ El número de la pieza
- ⑥ Facultativo el número del catálogo, el número de la lámina

Si los otros N^{os} del vehículo están destruidos : el número en la serie del tipo (véase el certificado de garantía)

ITALIANO

NELLE ORDINAZIONI DEI PEZZI DI RICAMBIO RICORDATE DI INDICARE :

- ① Il tipo del veicolo
- ② Il numero dell'equipaggiamento
- ③ Il numero di fabbricazione del veicolo
- ④ Il tipo ed il numero di fabbricazione dell'organo
- ⑤ Il numero del pezzo
- ⑥ Facoltativamente il numero di catalogo, il numero dell'illustrazione

Nel caso in cui gli altri Numeri del veicolo siano andati distrutti : il numero nella serie del tipo (vedere tessera di garanzia)

NEDERLANDS

GELIEVE BIJ HET BESTELLEN VAN ONDERDELEN HET VOLGENDE OP TE GEVEN :

- ① Het wagentype
- ② Het uitrustingsnummer
- ③ Het fabricagenummer van de wagen
- ④ Het type en het fabricagenummer van het orgaan
- ⑤ Het onderdeelnummer
- ⑥ Naar goedvinden : het onderdelenboeknummer, het afbeeldingsnummer

Wanneer de andere nummers van de wagen niet meer leesbaar zijn, moet opgegeven worden : het chassis-nummer (zie het garantiebewijs)

SVENSKA

VID BESTÄLLNING AV RESERVDEL OMBEDS NI ATT ANGE :

- ① Vagntyp
- ② Utrustningsnummer
- ③ Vagnens fabrikationsnummer
- ④ Enhetens typbeteckning och fabrikationsnummer
- ⑤ Delnummer
- ⑥ Dessutom och valfritt Katalognummer, Planschnummer

Om dessa uppgifter saknas eller ovala plåten försvunnit, uppges det på garantikortet stampade chassisnumret

INTRODUCTION

Le présent document contient tous les ensembles et pièces détachées vendables en rechange ; il permet de déterminer avec précision leurs numéros et de les identifier facilement par les illustrations.

Ces ensembles et ces pièces sont répartis par planches suivant l'organe ou l'élément d'organe auquel ils se rattachent.

Chaque **planche est identifiée** par un numéro à 4 chiffres dont les deux premiers correspondent à un code organe déterminé ; elle peut être caractérisée par une variante ou un point de départ dans le cas où elle s'identifie avec une planche similaire.

Une planche se compose :

de l'illustration des pièces et ensembles de l'organe détaillé qui diffèrent de forme ; à chaque pièce illustrée correspond un ou plusieurs numéros de pièces caractérisés entre eux par une variante ou un signe codifié et, éventuellement, de **tableaux** comportant des renseignements complémentaires tels que points de départ et consignes. Ces tableaux figurent soit en bas de l'illustration, soit sur une page annexe à l'illustration.

Remarque : la signification des signes et expressions codifiés utilisés dans chaque planche, est indiquée dans la planche n° 05-01.

Certaines pièces (vis, rondelles, écrous....) sont vendues en quantités déterminées (collections) sous un numéro nouveau, voir planche 94.01

Un **répertoire des planches** illustré indiqué sous chaque vignette représentée le numéro de planche à consulter.

Un **répertoire numérique** en fin de catalogue donne la correspondance entre les numéros de pièces et les numéros de planches ainsi que les quantités de pièces par véhicule dans la planche considérée.

Le document « P.R. 830 Renault » donne les caractéristiques des numéros de la boulonnerie normalisée.

UTILISATION

Détermination du numéro d'une pièce connaissant la nature de celle-ci

1. Rechercher dans le **répertoire des planches** la planche correspondant à l'organe ou l'élément d'organe auquel cette pièce peut se rattacher.
2. Compulser le catalogue pour y retrouver cette planche en tenant compte éventuellement, du point de départ ou de la variante caractérisant la planche.
3. La planche étant déterminée, rechercher l'illustration de la pièce désirée.

A cette illustration correspond un ou plusieurs numéros. Choisir celui qui convient, compte tenu des signes ou expressions codifiés les caractérisant.

Les renvois numériques ou alphabétiques affectés aux numéros de pièces, assurent la liaison entre ces numéros et les renseignements complémentaires contenus dans les tableaux situés soit en bas de l'illustration soit en page annexe.

Vérification, par les Succursales, Concessionnaires ou Centres importateurs, d'un bon de commande, rédigé par un Agent ou un client ayant utilisé la documentation en sa possession.

1. Rechercher dans le **répertoire numérique**, au numéro de pièce donné par le bon de commande, les numéros de planches correspondantes.
2. Consulter ces planches pour vérifier si le numéro de pièce est bien celui qui convient compte tenu des points de départ affectés à ce numéro et du numéro de véhicule ou d'organe pour lequel la pièce est commandée.

Identification par l'illustration d'une pièce dont on connaît le numéro.

1. Rechercher dans le **répertoire numérique**, au numéro de pièce donné, le numéro des planches correspondantes.
2. Consulter ces planches.

CONDITIONS GÉNÉRALES DE VENTE

Voir les tarifs de pièces de rechange.

INDLEDNING

Nærværende katalog indeholder alle enheder samt alle monterede originale løsele, som er salgbare ved udskiftning; det er med lethed muligt at identificere delene ved hjælp af illustrationerne. Disse samlede enheder, og løsele er fordelt på plancher, idet de er vist i forbindelse med vogndelen eller enheden, hvorpå de skal monteres.

Hver planche er mærket med et nummer bestående af 4 tal, hvorat de to første svarer til et kodetal på en bestemt vogndel; hvor flere plancher er identiske er disse yderligere tilføjet bemærkning med angivelse af afvigelse eller begrænsninger af delenes anvendelse.

En planche består af :

en illustration af de forskellige dele og sæt; til hver del svarer et eller flere numre, som skelnes fra hinanden ved en afvigelse eller et kodetegn.

eventuelt **tabeller**, som indeholder oplysninger om begrænsninger af delenes anvendelse, om delenes dimensioner o. l. Disse tabeller er anført enten forneden på illustrationen eller på en tillægsside.

Bemærk : Forklaring på kodetegn og kodeudtryk, som avendes på plancherne, findes på planche nr. 05-01...

Visse dele (bolte, skiver, møtrikker....) leveres i bestemte kvanta under nyt nummer, se planche 94.01

På en oversigt over de illustrerede plancher er under hvert billede anført den pågældende enheds planchenummer.

En **nummerfortegnelse** bagest i kataloget viser, hvorledes reservedelsnumre og planchenumre svarer til hinanden samt delantal pr. vogn på den pågældende planche (I kataloget « P.R. 830 » findes specifikationer over numrene på standardiserede boltevarer).

ANVENDELSE

Fastsættelse af nummeret på en del man kender :

1. Find i registeret over plancher den planche, som svarer til den vogndel, eller enhed på hvilken reservedelen er beregnet til at blive monteret.
2. Slå op i kataloget og find denne planche, idet. De holder Dem til eventuelle afvigelser og kodetegn der måtte stå på planchen.
3. Når den rigtige planche er fundet, find da billedet af den ønskede del; til dette billede svarer et eller flere numre; vælg det, der passer i henhold til kodetegn eller kodeudtryk.

De meld tal eller bogstaver mærkede henvisninger ved del nummeret gør det muligt at finde forbindelsen mellem disse numre og de yderligere oplysninger der findes enten nederst på planchen eller på tillægssiden.

Ordresedler, der udstedes af en agent eller en kunde ved hjælp af vedlagte reservedelskatalog, skal kontrolleres af den koncessionerede forhandler eller af importøren.

1. Find i registeret over reservedelsnumre nummeret på den planche, som reservedelsnummeret henviser til.
2. Se på plancherne for at afgøre om det er de rigtige numre, idet De holder Dem til eventuelle afvigelser of kodetegn samt vognnummeret, som delene er bestilt til.

Fastsættelse ved hjælp af illustration af en del, hvis nummer man kender.

1. Find i registeret over reservedelsnumre nummeret på den planche, som reservedelsnummeret henviser til.
2. Slå op på planchen.

ALMINDELIGE SALGSBETINGELSER

Se reservedels-orislisten

VORWORT

Die vorliegende Ausgabe enthält alle montierten Einzelteile, die als Ersatzteile verkäuflich sind. Sie ermöglicht es, die Nummern mit Genauigkeit zu bestimmen und sie anhand der Abbildungen zu identifizieren.

Diese Aggregate und Teile sind in **Bildtafeln** aufgeteilt, und zwar ihrer Zugehörigkeit entsprechend.

Jede **Bildtafel** ist mit einer vierstelligen Nummer versehen, wovon die ersten zwei Ziffern einem bestimmten Organ-Schlüssel entsprechen; sie kann durch eine Variante oder einen Ausgangspunkt der Ersatzteilnummer gekennzeichnet sein, wenn sie mit einer gleichartigen Bildtafel übereinstimmt.

Eine **Bildtafel** setzt sich zusammen aus: den Abbildungen der Aggregate und Teile, die in der Form voneinander abweichen; jedem dargestellten Teil entsprechen eine oder mehrere Teilnummern, untereinander gekennzeichnet durch eine Variante oder ein verschlüsseltes Zeichen, sowie gegebenenfalls Tabellen mit zusätzlichen Angaben wie z.B. Ausgangspunkt einer Ersatzteilnummer und besondere Hinweise. Diese **Tabellen** sind entweder unten auf der Bildtafel oder aber auf einer gesonderten Anhangseite aufgeführt.

Anmerkung: Die Erklärung der verschlüsselten Zeichen und Ausdrücke, die auf den Bildtafeln erscheinen, finden Sie auf Seite 05.01...

Einige Teile (Schrauben, Unterlegscheiben, Muttern....) werden unter neuer Bestellnummer nur in Verpackungseinheiten geliefert, siehe Seite 94.01

Auf einem Bildverzeichnis finden Sie unter der Umrisszeichnung der einzelnen Aggregate die Nummer der Bildtafel, auf der die entsprechenden Teile zu finden sind.

Am Ende des Kataloges finden Sie ein numerisches Sachregister nach Teilnummern mit den dazugehörigen Bildtafeln sowie der Anzahl gleicher Teile pro Fahrzeug auf der Bildtafel.

(Ausgenommen sind die Nummern des genormten Schraubenzubehörs, die dem Katalog PR 830 zu entnehmen sind.)

GEBRAUCHSANWEISUNG

Bestimmung der Nummer eines Teiles, dessen Beschaffenheit bekannt ist:

1. Im **Bildtafelverzeichnis** die Nummer der Bildtafel suchen, zu der das Teil oder Aggregat gehört.
2. Im Katalog diese Bildtafel nachschlagen und gegebenenfalls die Variante oder den Ausgangspunkt, die die Bildtafel kennzeichnen, berücksichtigen.
3. Für das Teil sind — auf der Bildtafel — eine oder mehrere Nummern angegeben. Bei der Wahl der richtigen Nummer sind eventuelle verschlüsselte Zeichen und Ausdrücke zu berücksichtigen. Anstelle der Ersatzteilnummer erscheint sehr oft eine einzelne Zahl. Dieselbe wird unten auf der Bildtafel wiederholt und weist auf zusätzliche Angaben hin.

Prüfen eines Bestellscheines, den ein Unterhändler oder Kunde mit der ihm zur Verfügung stehenden Fachliteratur (Katalog usw.) ausgestellt hat.

1. Im **numerischen Sachregister** unter der auf dem Bestellschein angegebenen Teilnummer die entsprechende Bildtafel suchen.
2. Die Bildtafel aufschlagen und prüfen, ob die angegebene Nummer richtig ist. Daher müssen die vorher schon genannten besonderen Hinweise beachtet werden.

Identifizierung eines Teiles, dessen Nummer bekannt ist, anhand der Abbildung:

1. Im numerischen Sachregister unter der bekannten Teilnummer die Nummer der entsprechenden Bildtafel herausuchen.
2. Diese Bildtafel zu Rate ziehen.

ALLGEMEINE VERKAUFSBEDINGUNGEN

Siehe Ersatzteil-Preisliste.

INTRODUCTION

This document contains all the assemblies and parts sold as spares; it enables one to determine with precision their numbers and to identify them easily by the illustrations.

These assemblies and these parts are set out in **illustrated plates** according to the unit or sub-assembly to which they belong. Each **plate** is identified by a four figure number, the first two of which correspond to a specified unit code; it may be distinguished by a variant or a starting point in the case where it is identifiable with a similar plate.

A plate consists of:

the illustration of parts and assemblies of the unit shown which differ in shape; one or several numbers correspond to each part illustrated and these are distinguished one from the other by a variant or symbol and if necessary **tables** showing additional information such as starting points and instructions. These tables are found on the bottom of the illustration or on a page added to the illustration.

Note: the meanings of the symbols and coded expressions used on each plate are listed on Plate No. 05.01...

Some parts (bolts, washers, nuts....) are sold in fixed quantities (sets) under a new Part Number, see plate 94.01

A **list of illustrated plates** gives the Plate Number to refer to under each square.

A **numerical index** at the end of the catalogue gives the relationship between the part numbers and the plate numbers also the parts quantity required per vehicle in the plate concerned. (The « Renault — P.R. 830 » catalogue gives the specifications for all the standard bolt part numbers).

USE

Ascertaining a part Number knowing the nature of this part:

1. In the **plate index**, find the plate corresponding to the unit or sub-assembly to which this part may be attached.
2. Consult the catalogue to find this plate, when necessary taking into account the starting point or the variant distinguishing this plate.
3. Having found the plate, look for the illustration of the desired part. One or several numbers correspond to this illustration; choose the suitable number, taking into account code signs or expressions which distinguish them.

The numerical or alphabetical reference marks added to the part number, ensure the connection between these numbers and the additional information appertaining to them, included in the tables found at the bottom of the illustration or on the additional page.

Checking by Branches, Distributors or Importation Centres of an Order Form which has been filled in by an Agent or by a client using the documents in his possession.

1. In the **numerical index**, at the part number indicated on the order form, find the corresponding plate numbers.
2. Examine these plates to check that the part number given is correct taking into account the starting points added to this number and the number of the vehicle or unit for which the part has been ordered.

Identifying by the illustration a part the number of which is known.

1. In the numerical index, at the given part number find the corresponding plate numbers.
2. Consult these plates.

GENERAL SALES CONDITIONS

See the spare parts price lists.

INTRODUCCION

Este documento contiene todos los conjuntos y las piezas sueltas vendidas como repuestos; con él, los números se hallan con precisión y por medio de las láminas se les puede identificar con toda facilidad.

Estos conjuntos y piezas van repartidos por láminas, según el órgano o el elemento de órgano al que pertenecen.

Todas las láminas llevan un número de cuatro cifras, las dos primeras de las cuales corresponden a la anotación codificada del órgano; cuando la lámina pueda confundirse con otra similar, lleva especificada la variante en cuestión o el número del punto de partida.

Una lámina se compone :

de la ilustración de las piezas y conjuntos del órgano detallado que difieren de forma ; a cada pieza ilustrada corresponde uno o varios números de piezas que se caracterizan entre ellos por una variante o un signo codificado y, eventualmente, de cuadros en los que se indican informaciones complementarias tales como puntos de partida y consignas. Estos cuadros figuran, ya sea debajo de la ilustración, ya sea en una página anexa a la ilustración.

Observación : la significación de los signos y expresiones codificados utilizados en cada lámina, va indicada en la lámina n° 05.01...

Ciertas piezas (tornillos, arandelas, tuercas, etc.) son vendidas por cantidades determinadas (colecciones) bajo un número nuevo, ver la lámina 94.01

Un repertorio de las láminas ilustradas indica, debajo de cada figura representada el número de la lámina que hay que consultar.

Al final del catálogo existe un repertorio numérico que indica la correspondencia entre los números de las piezas y los números de las láminas, así como las cantidades de piezas por vehículo en la lámina considerada (El documento « P.R. 830 Renault » da las características de los números de la tornillería normalizada).

MODO DE EMPLEO

Determinación del número de una pieza, conociendo la naturaleza de la misma :

1. Buscar en la lista de láminas, la lámina correspondiente al órgano o al elemento de órgano al que la pieza puede pertenecer.

2. Consultar el Catálogo y buscar la lámina, teniendo en cuenta en caso preciso, el punto de partida o la variante característica de la lámina.

3. Una vez encontrada la lámina, buscar la ilustración de la pieza deseada. A esta ilustración corresponde uno o varios números; elegir entre ellos el que conviene, habida cuenta de los signos o expresiones convencionales que le acompañan. Las citas numéricas o alfabéticas que acompañan al número de pieza sirven para unirlos a los informes complementarios que le conciernen ; estos informes se hallan en la parte inferior de la página o en hoja anexa (cuadros).

Verificación por las Sucursales, Concesionarios o los Centros Importadores, de un vale de pedido, redactado por un agente o un cliente, a base de la documentación que posee.

1. Buscar en la lista numérica, en el número de pieza señalado por el pedido, los números de las láminas correspondientes.

2. Consultar las láminas para comprobar si el número de la pieza es el que conviene, habida cuenta de los puntos de partida correspondientes a ese número y del número del vehículo o del órgano para el que se pide la pieza.

Identificación por la ilustración de una pieza cuyo número se conoce.

1. Buscar en la lista numérica, en el número de pieza dado, el número de las láminas correspondientes.

2. Consultar estas láminas.

CONDICIONES GENERALES DE VENTA

Véanse las tarifas de las piezas de recambio.

PREMESSA

La presente raccolta contiene tutti i gruppi e i pezzi staccati, venduti come ricambi ; permette di determinare con precisione i loro numeri e identificarli facilmente per mezzo delle illustrazioni. Questi gruppi e questi pezzi sono ripartiti per Tavole secondo l'organo o l'elemento di organo al quali si riferiscono.

Ogni Tavola è identificata da un numero a 4 cifre delle quali le prime due corrispondono ad un determinato gruppo di organi ; può essere caratterizzata da una variante od un punto di partenza nel caso in cui essa si identifichi con una tavola analoga.

Una tavola si compone :

dell'illustrazione dei particolari e dei complessivi dell'organo particolareggiato che si differenziano dalla forma ; ad ogni particolare illustrato corrisponde uno o più numeri di particolari caratterizzati tra loro da una variazione o da un segno codificato e, eventualmente, da tabelle che contengono informazioni complementari come dei punti di partenza e delle istruzioni. Queste tabelle si trovano sia sotto l'illustrazione, sia su una pagina allegata all'illustrazione.

Osservazione : il significato dei segni e delle espressioni codificati utilizzati su ogni tavola è indicato nella tavola n. 05-01...

Alcuni particolari (viti, rondelle, dadi,...) sono venduti in determinate quantità (collezioni) con un nuovo numero, vedi tavola 94.01

Una rubrica delle tavole illustrate indica sotto ogni disegno il numero della tavola in riferimento.

Un riepilogo numerico alla fine del catalogo segnala la corrispondenza tra i numeri dei particolari ed i numeri delle tavole così come i quantitativi dei particolari per veicolo sulla tavola considerata. (Il documento « P.R. 830 Renault » dà le caratteristiche dei numeri della bulloneria normalizzata).

USO DEL CATALOGO

Determinazione del numero di un pezzo conoscendo la sua natura :

1. Cercare nell'indice delle tavole, la tavola corrispondente all'organo o all'elemento di organo al quale questo pezzo può riferirsi.

2. Consultare il Catalogo per trovare questa tavola tenendo conto eventualmente, del punto di partenza o della variante che caratterizza la tavola.

3. Determinata la tavola, cercare l'illustrazione del pezzo desiderato. A questa illustrazione corrispondono uno o più numeri; scegliere quello che conviene, tenendo conto dei segni od espressioni codificate che li caratterizzano. I rinvii numerici od alfabetici in corrispondenza del numero del pezzo, assicurano il collegamento fra questi numeri e le informazioni complementari che vi si riferiscono, contenuti nelle tabelle situate sia in calce all'illustrazione, sia nella pagina allegata.

Verifica, da parte delle Succursali, Concessionari o Centri Importatori, di un buono di ordinazione, redatto da un Agente o da un cliente che avrebbe usato la documentazione in suo possesso :

1. Cercare nell'indice numerico, al numero di pezzo dato dal buono di ordinazione, i numeri delle tavole corrispondenti.

2. Consultare queste tavole per controllare se il numero del pezzo è quello che corrisponde tenendo conto dei punti di partenza attribuiti a questo numero e del numero del veicolo o dell'organo per il quale il pezzo è stato ordinato.

Identificazione per mezzo dell'illustrazione di un pezzo del quale si conosce il numero :

1. Cercare nell'indice numerico, al numero di pezzo dato, il numero delle tavole corrispondenti.

2. Consultare queste tavole.

CONDIZIONI GENERALI DI VENDITA

Vedi tariffa pezzi di ricambio.

INLEIDING

In deze catalogus zijn alle onderdeelgroepen en afzonderlijke onderdelen vermeld welke voor repartiedoeleinden worden verkocht. De onderdelen zijn met de juiste nummers aangeduid en kunnen aan de hand van de afbeeldingen gemakkelijk worden geïdentificeerd. De onderdeelgroepen en afzonderlijke onderdelen zijn in elke **plaat** gegroepeerd volgens het orgaan of deel van het orgaan waartoe zij behoren. Iedere **plaat** is aangeduid met een nummer van vier cijfers, waarvan de eerste twee cijfers corresponderen met een code voor het betreffende orgaan. Hiervan kan zijn afgeweken in geval de aanduiding betrekking heeft op een overeenkomstige plaat.

Een bladzijde bestaat uit :

Een afbeelding van de onderdelen en de samenstellende onderdelen van een onderdeelgroep die een verschillende vorm hebben; bij ieder afgebeeld onderdeel behoren een of meerdere nummers.

Bij meerdere nummers wordt een codetecken gebruikt om het verschil aan te geven. In een **tabel** staan eventueel aanvullende gegevens zoals beginnummers en aanwijzingen, deze tabel staat of onderaan of op de volgende bladzijde.

Opmerking : de verklaring van de gebruikte codetekens en afkortingen wordt op blz 05-01 gegeven.

Bepaalde onderdelen (bouten, ringen, moeren....) worden per vaste hoeveelheid (zakje) verkocht onder een nieuw nummer, zie bladzijde 94.01

In de **inhoudsopgave** wordt onder iedere afbeelding het nummer van de bijbehorende bladzijde genoemd.

Met de **numerieke opgave** achterin het boek kunt u verband leggen tussen de onderdeelnummers, de afbeelding en het aantal van deze onderdelen op de betreffende bladzijde.

In de P.R. 830 Renault worden de gegevens en nummers van bouten en moeren genoemd.

GEBRUIKSAANWIJZING

Bepalen van het onderdeelnummer wanneer de soort van het onderdeel bekend is.

1. Zoek in de **inhoudsopgave** de **plaat** welke betrekking heeft op het orgaan waarvan het betreffende onderdeel deel uitmaakt.
2. Zoek in de catalogus deze **plaat** op, rekening houdend met eventueel afwijkende gegevens, zoals begin van uitgave en afwijkende aanduiding welke de plaat kenmerken.
3. Wanneer de plaat gevonden is, zoekt men daarin de afbeelding van het gewenste onderdeel op. Bij deze afbeelding staan één of meer nummers; kies hieruit het juiste nummer, rekening houdend met de kenmerkende codemerktekens of aanduidingen. De aanduidingen in cijfers of letters bij het onderdeelnummer verwijzen naar de aanvullende nummers en aanwijzingen (indien van toepassing), welke zijn vermeld in de tabellen onder de plaat of op de tegenoverliggende bladzijde.

Controle door de filialen, agenten of importeurs van een bestelbon, opgesteld door een subagent of een client, die gebruik heeft gemaakt van de in zijn bezit zijnde documentatie.

1. Zoek in de **numerieke inhoudsopgave** aan de hand van het in de bestelbon gegeven onderdeelnummer de betreffende plaatnummers op.
2. Raadpleeg de platen om te controleren of het opgegeven onderdeelnummer wel het juiste is, rekening houdend met begin van uitgave van het nummer en het wagennummer of nummer van het orgaan waarvoor het onderdeel wordt besteld. **Identificatie van een onderdeel aan de hand van de afbeelding**, wanneer het onderdeelnummer bekend is.

1. Zoek het nummer van de betreffende platen aan de hand van het juiste onderdeelnummer in de numerieke inhoudsopgave.

2. Raadpleeg de platen.

ALGEMENE VERKOOPSVOORWAARDEN

Zie de onderdelentarievenlijsten.

INLEDNING

Föreliggande katalog innehåller en förteckning över reservdelar och kompletta enheter, som kan monteras vid reparation. Den gör det möjligt att exakt-fastställa delarnas nummer och att identifiera dem med ledning av illustrationerna.

Varje detalj och varje enhet kan återfinnas på en bild, föreställande den huvudenhet i vilken detaljen ingår.

Varje **planschsida** har ett 4-siffrigt nummer av vilket de två första siffrorna motsvarar en kodbeteckning för huvudenheten eller organet ifråga; avbildningen kan ha en variant eller en konstruktionsändring med utgång från ett visst fabriktionsnummer och i sådant fall finnes två likartade planscher.

En plansch innehåller :

— **avbildning** av delarna och den enhet i vilken dessa ingår. Varje avbildad detalj kännetecknas av ett eller flera reservdelsnummer, sinsemellan åtskilda med ett variantnummer eller en kodbeteckning.

— eventuellt en tablå som ger kompletterande upplysningar såsom från vilket fabriktionsnummer en viss detalj monteras eller vilka delar som ytterligare erfordras vid utbyte. Dessa tablåer återfinns antinge längst ned på planschen eller på ett annexblad intill.

Anm : Förklaring till de märken och beteckningar som används genomgående i hela boken återfinns på plansch nr. 05-01...

Vissa detaljer (skruvar, brickor, muttrar mm) säljes i fastställt antal (satser) under nytt nummer, se plansch 94.01

Innehållsförteckningen med bilder anger de olika planschnummer på vilka de avbildade detaljerna återfinns.

I slutet av katalogen finns en referenslista över reservdelsnummer och planschnummer samtidigt som uppgift om antalet av varje detalj som avgår. Se P.R. 830 Renault beträffande bultar.

ANVÄNDNING

Fastställande av numret på en viss reservdel tillgår på följande sätt :

1. Sök i **bildregistret** upp den bild som omfattar den huvudenhet i vilken den aktuella delen ingår eller med vilken den sammanhänger.
2. Sök upp denna plansch i katalogen och tag därvid hänsyn till eventuellt förekommande variant- eller fabriktionsnummer.
3. Då den önskade planschen återfunnits skall den eftersökta delen uppsökas. Till den avbildade delen finnes ett eller flera reservdelsnummer och man skall välja det nummer, som motsvarar de märken eller kodbeteckningar som betecknar den del man vill ha.

De siffror eller bokstäver som kan förekomma framför eller efter ett reservdelsnummer hänvisar till kompletterande upplysningar om detaljen och återfinnes i en tablå längst ned på sidan eller på vidstående sida.

Filialers och centralimportörers kontroll av beställningssedel, som utskrivits av en representant eller en kund med ledning av tillgänglig dokumentation.

1. Leta i nummerregistret med ledning av det reservdelsnummer som framgår av beställningssedeln, reda på numret på motsvarande bild.
2. Kontrollera med ledning av planschen att det uppgivna reservdelsnumret är det riktiga med hänsyn till det uppgivna fabriktionsnumret.

Identifiering med ledning av en bild av en detalj vars nummerbeteckning är känd :

1. Sök med ledning av nummerregistret upp numret på den bild som upptar den aktuella detaljen.

2. Slå upp denna bild.

ALLMÄNNA FÖRSÄLNINGSVILKOR

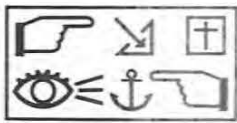

05.01

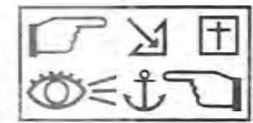

05.01

	FRANÇAIS	DANSK	DEUTSCH	ENGLISH
	ESPAÑOL	ITALIANO	NEDERLANDS	SVENSKA
.../000	Numero d'equipement	Udstyrsnummer	Ausrüstungsnummer	Equipment version number
	Numero de su equipo	Numero di equipaggiamento	Uitrustingsnummer	Utrustningsnummer
	Direction à gauche ☞ 05.40	Venstrestyret ☞ 05.40	Linkslenkung ☞ 05.40	L. H. drive ☞ 05.40
	Dirección a la izquierda ☞ 05.40	Guida a sinistra ☞ 05.40	Links stuur ☞ 05.40	Vänsterstyrd ☞ 05.40
	Direction a droite ☞ 05.40	Højrestyret ☞ 05.40	Rechtslenkung ☞ 05.40	R.H. drive ☞ 05.40
	Dirección a la derecha ☞ 05.40	Guida a destra ☞ 05.40	Rechts stuur ☞ 05.40	Högerstyrd ☞ 05.40
	Véhicule	Vogntype	Fahrzeug	Vehicle
	Vehículo	Veicolo	Auto	Bil
	Groupe	Kraftenhed (motor)	Antriebsgruppe	Power unit
	Grupo	Gruppo	Groep (motor)	Drivaggregat
	Moteur	Motor	Motor	Engine
	Motor	Motore	Motor	Motor
	Boîte pont ou boîte de vitesse	Gearkasse-differentiale eller gearkasse	Getriebe-Differential oder Wechselgetriebe	Gearbox-transmission or gearbox
	Caja-puente o caja de cambios	Scatola differenziale o scatola cambio	Versnellingsbak / differentieel of versnellingsbak	Växellada-bakaxel eller växellada
+	Pièce fournie jusqu'à épuisement des stocks.	Leveres indtil beholdningen er obrugt	Teil wird bis zur Auflösung des Lagerbestandes geliefert	Part supplied until stocks exhausted
	Pieza que se suministrará hasta que se terminen las existencias	Particolare da esaurire	Onderdeel dat geleverd wordt zolang de voorraad strekt	Detaljen utförsäljes
+	Après épuisement, prévoir	Efter udgået lager bestil	Nach Auslaufen vorsehen	After exhaustion of stock, supply
	Una vez agotada, prever	Dopo esaurimento prevedere	Te gebruiken nadat de bestaande voorraad is uitgeput	Efter utförsäljning levereras
	Pièces à prévoir en supplément	Bestilling af ekstradele	Teile zusätzlich vorzusehen	Additional parts to be provided
	Piezas suplementarias	Pezzi da prevedere in supplemento	Aanvullend in voorraad te nemen onderdelen	Supplementdelar
?	Consignes d'interchangeabilité	Når udskiftning tilrådes, bruges følgende tegn	Anweisungen für die Austauschbarkeit symbolisiert durch	Interchangeability instructions
	Consignas de intercambiabilidad, simbolizadas por	Istruzioni per l'intercambiabilità simbolizzate da	Aanwijzingen betreffende verwisselbaarheid, aangeduid door	Anvisningar för utbyte

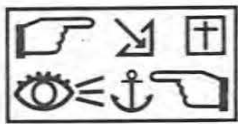

05.02



05.02

	Pour	Til	Für	For
	Para	Per	Voor	För
	Sauf	Uden	Ausser	Except
	Excepto	Eccetto	Uitgezonderd	Utom
	à	til	bis	to
	a	a	tot	till
#	Indique qu'il s'agit d'un chiffre prévisionnel d'application	Angiver at det drejer sig om et beregnet ændringstidspunkt		Indicates that this concerns a provisional application number
	Indica que se trata de una cifra provisional de aplicación	Indica che si tratta d'un numero previsionale d'applicazione	Geeft aan dat dit een voorlopig nummer voor de toepassing is	Ange att det gäller beräknad tillämpning
&	et	og	Und	And
	y	e	en	Och
	Équipement facultatif	Valgfrit udstyr	Ausrüstung auf Wunsch	Optional equipment
	Equipo opcional	Equipaggiamento facoltativo	Behoort niet tot de standaard-uitrusting	Valfri-utrustning
	Gratuit	Gratis	Gratis	Free of charge
	Gratuito	Gratiso	Gratis	
	Payant	Mod beregning	Wird berechnet	Chargeable
	De pago	A pagamento	Betalend	
	Voir planche ou voir page	Se planche eller se side	Siehe Bildtafel oder Seite	"See plate" or "see page"
	Ver lámina o ver página	Vedi tavola o vedi pagina	Zie afbeelding of biz	Se plansch eller sida
	Unité de vente	Salgsenhed	Verkaufseinheit	Sold in following quantities
	Unidad de venta	Unità di vendita	Verkoopseenheid	Försäljningslängd
	Vente en longueur de fabrication	Salg efter fabrikationslængde	Verkauf nach Fabrikationslängen	Sold in manufactured length
	Venta a la longitud de fabricación	Vendita in lunghezza di fabbricazione	Verkoop in fabricagelengte	Försäljning per tillverkningslängd
	Ou bien	Eller	Oder	Or
	O bien	Oppure	Of wel	Eller

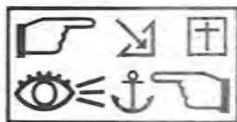

05.03

05.03

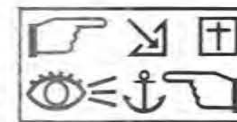

%	Conditions spéciales d'échange	Særlige ombytningsbetingelser	Spezial-Austauschbedingungen	Special conditions for replacement
	Condiciones generales de cambio	Speciali condizioni per la sostituzione	Speciale ruil condities	Villkor för speciell utbytesservice
	Emplacement du marquage sur l'ensemble ou la pièce	Placering af mærkningen på enheden eller delen	Lage der Markierung am Teil oder an der Baugruppe	Position of the marking on the assembly or the part
	Emplazamiento de la marca en el conjunto o en la pieza	Spazio riservato al contrassegno di riferimento sul complessivo o sul particolare	Plaats van het typeplaatje van de groep of het onderdeel	Plats för typskylt
	Pièces vendues en collection sous un seul numéro	Leveres i sæt under eet nummer	Unter einer einzigen Nummer als Satz verkaufte Teile	Parts sold as a kit under one part number
	Piezas vendidas por colecciones bajo un solo número	Particolare venduti in serie con un'unico numero	Onderdelen, die als set onder één nummer verkocht worden	Delar sålda endast per sats
X	Pièces vendues en quantité déterminée Voir planche 94.01	Delene leveres i bestemt antal Se planche 94.01	Verkauf erfolgt in Verpackungseinheiten Siehe Bildtafel 94.01	Parts sold in a fixed quantity See sheet 94.01
	Piezas vendidas por cantidad determinada Ver la lámina 94.01	Particolari venduti in quantità determinata Vedi tavola 94.01	Onderdelen die in een bepaalde hoeveelheid verkocht worden Zie afbeelding 94.01	Detaljer sålda i fastställt antal Se plansch 94.01
1i	Boîte-pont ou boîte de vitesses avec commandes à la planche de bord	Gearkasse-differentiale eller gearkasse med panelgear	Getriebe-Differential oder Wechselgetriebe mit Betätigungen am Armaturenbrett	Gearbox-transmission or gearbox with dashboard mounted gear shift
	Caja-puente o caja de cambios con mandos en tablero	Differenziale o cambio con leve di comando sul cruscotto	Versnellingsbak-differentieel of versnellingsbak met dashboardschakeling	Växellada-differential eller växellada med växelspak genom instrumentbrädan
2i	Boîte-pont ou boîte de vitesses avec commandes au plancher	Gearkasse-differentiale eller gearkasse med bundgear	Getriebe-Differential oder Wechselgetriebe mit Betätigungen am Bodenblech	Gearbox-transmission or gearbox with floor mounted gear shift
	Caja-puente o caja de cambios con mandos en el piso	Differenziale o cambio con leve di comando al pianale	Versnellingsbak-differentieel of versnellingsbak met vloerschakeling	Växellada-differential eller växellada med golvväxelspak
3i	3 vitesses	3-trins	3-Gang	3 speed
	3 velocidades	3 marce	3 versnellingen	3-växlad
4i	4 vitesses	4- trins	4-Gang	4 speed
	4 velocidades	4 marce	4 versnellingen	4-växlad
5i	5 vitesses	5-trins	5-Gang	5 speed
	5 velocidades	5 marce	5 versnellingen	5-växlad
1	1e vitesse	1. gear	1. Gang	1st speed
	1ª velocidad	1a velocidad	1e versnelling	1:an
2	2e vitesse	2. gear	2. Gang	2nd speed
	2ª velocidad	2a velocidad	2e versnelling	2:an
3	3e vitesse	3. gear	3. Gang	3rd speed
	3ª velocidad	3a velocidad	3e versnelling	3:an



05.04

05.04

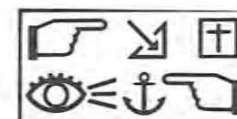



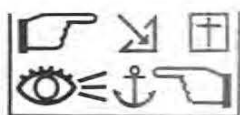





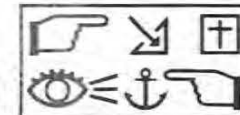



	4 ^e vitesse	4. gear	4. Gang	4 th Speed
	4 ^a velocidad	4a velocit�	4e versnelling	4:an
	5 ^e vitesse	5. gear	5. Gang	5th speed
	5 ^a velocidad	5a velocit�	5e versnelling	5:an
	1e et 2e vitesses	1. og 2. gear	1. und 2. Gang	1st and 2nd speeds
	1 ^a y 2 ^a velocidades	1a e 2a velocit�	1e en 2e versnelling	1:an och 2:an
	2e et 3e vitesses	2. og 3. gear	2. und 3. Gang	2nd and 3rd speeds
	2 ^a y 3 ^a velocidades	2a e 3a velocit�	2e en 3e versnelling	2:an och 3:an
	3e et 4e vitesses	3. og 4. gear	3. und 4. Gang	3rd and 4th speeds
	3 ^a y 4 ^a velocidades	3a e 4a velocit�	3e en 4e versnelling	3:an och 4:an
	4e et 5e vitesses	4. og 5. gear	4. und 5. Gang	4th and 5th speeds
	4 ^a y 5 ^a velocidades	4a e 5a velocit�	4e en 5e versnelling	4:an och 5:an
	Marche arri�re	Bakgear	R�ckw�rtsgang	Reverse
	Marcha atr�s	Retromarcia	Achteruit	Back
	1e vitesse - Marche arri�re	1. gear - Bakgear	1. Gang - R�ckw�rtsgang	1st speed - Reverse
	1 ^a velocidad - Marcha atr�s	1a velocit� - Retromarcia	1e versnelling - Achteruit	1:an - Back
	Nombre de dents	Tandantal	Anzahl der Z�hne	Number of teeth
	N�mero de dientes	Numero dei denti	Aantal tanden	Antal kuggar
	Denture ext�rieure : Nombre de dents (exemple : 10 dents)	Udvendige t�nder : Antal t�nder (For eksempel : 10 t�nder)	Aussere Verz�hung : Anzahl der Z�hne (Beispiel : 10 Z�hne)	External teeth : Number of teeth (For Example : 10 teeth)
	Dentado exterior : N�mero de dientes (ejemplo : 10 dientes)	Dentatura esterna : numero dei denti (esempio : 10 denti)	Uitwendige vertanding : Aantal tanden (voorbeeld : 10 tanden)	Bommar, utv�ndiga : Antal (exempel : 10 st)
	Denture int�rieure : Nombre de dents (exemple : 10 dents)	Indvendige t�nder : Antal t�nder (For eksempel : 10 t�nder)	Innere Verz�hung : Anzahl der Z�hne (Beispiel : 10 Z�hne)	Internal teeth : Number of teeth (For Example : 10 teeth)
	Dentado interior : N�mero de dientes (ejemplo : 10 dientes)	Dentatura interna : numero dei denti (esempio : 10 denti)	Inwendige vertanding : Aantal tanden (voorbeeld : 10 tanden)	Bommar, inv�ndiga : Antal (exempel : 10 st)
	Admission	Indsugning	Einlass	Inlet
	Admisi�n	Aspirazione	Inlaat	Insugning



05.05

05.05



	Echappement	Udstødning	Auspuff	Exhaust
	Escape	Scarico	Uitlaat	Avgassystem
	Projecteur longue portée	Fjernprojektor	Fernscheinwerfer	Long range driving light
	Proyector de largo alcance	Faro a lunga portata	Verstraler	Fjärrljusstrålkastare
	Projecteur antibrouillard	Tågelygte	Nebelscheinwerfer	Foglight
	Proyector antiniebla	Faro fendinebbia	Mistlamp	Dimljusstrålkastare
	Embrayage simple	Kobling almindelig	Einscheibenkupplung	Single plate clutch
	Embrague sencillo	Frizione semplice	Enkelvoudige koppeling	Växlingsberoende koppling
	Voiture à transmission automatique	Vogn med automatisk transmission	Fahrzeuge mit Automatic-Getriebe	Car fitted with automatic transmission
	Coche con transmisión automática	Veicolo a trasmissione automatica	Wagen met automatische transmissie	Automatväxlat fordon
	Freins avec rattrapage automatique d'usure	Selvjusterende bremsler	Bremsen mit automatischer Nachstellvorrichtung	Brakes with self-adjusting mechanism
	Frenos con aproximación automática de zapatas	Freni autoregolabili del logorio delle guarnizioni	Remmen met automatische stelrichting	Självjusterande bromsar
	Freins sans rattrapage automatique d'usure	Justerbare bremsler	Bremsen ohne automatische Nachstellvorrichtung	Brakes without self-adjusting mechanism
	Frenos sin aproximación automática de zapatas	Freni non autoregolabili del logorio delle guarnizioni	Remmen zonder automatische stelrichting	Icke självjusterande bromsar
	Véhicule avec conditionnement d'air	Med air-condition-anlæg	Fahrzeuge mit Klimaanlage	Vehicle with air conditioning
	Vehículo con acondicionamiento de aire	Veicolo con condizionamento d'aria	Auto met airconditioning	
	Véhicule sans conditionnement d'air	Uden air-condition-anlæg	Fahrzeuge ohne Klimaanlage	Vehicle without air conditioning
	Vehículo sin acondicionamiento de aire	Veicolo senza condizionamento d'aria	Auto zonder airconditioning	
	Avec condamnation électromagnétique des serrures de portes	Med elektromagnetisk låsning af dørene	Mit elektromagnetischer Türverriegelung	With electro-magnetic door locking mechanism
	Con enclavamiento electromagnético de las cerraduras de las puertas	Con dispositivo di sicurezza elettromagnetico delle serrature di porte	Met electromagnetische vergrendeling van de portiersloten	Med elektromagnetisk spärning av dörrlåsen
	Sans condamnation électromagnétique des serrures de portes	Uden elektromagnetisk låsning af dørene	Ohne elektromagnetische Türverriegelung	Without electro-magnetic door locking mechanism
	Sin enclavamiento electromagnético de las cerraduras de las puertas	Senza dispositivo di sicurezza elettromagnetico delle serrature di porte	Zonder electromagnetische vergrendeling van de portiersloten	Utan elektromagnetisk spärning av dörrlåsen
	Véhicule avec servo-direction	Med servo-styring	Fahrzeug mit Servo-Lenkung	Vehicle with power-assisted steering
	Vehículo con servodirección	Veicolo con servo-sterzo	Auto met stuurbekrachtiging	Bil med servostyrning

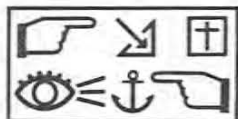

05.06

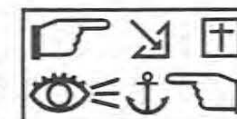

05.06

	Véhicule sans servo-direction	Uden servo-styring	Fahrzeug ohne Servo-Lenkung	Vehicle without power-assisted steering
	Vehículo sin servodirección	Veicolo senza servo-sterzo	Auto zonder stuurbekrachtiging	Bil utan servostyrning
B	Vitres incolores	Klart glas	Farblosen Scheiben	Clear glass
	Lunas incoloras	Cristalli incolori	Heldere ruiten	Ofärgat glas
B	Vitres teintées	Tonet glas	Getönte Scheiben	Tinted glass
	Lunas de color	Cristalli colorati	Gekleurde ruiten	Färgat glas
	Désembuage lunette arrière	Bagrude med varmetråde	Heckscheibenbeheizung	Rear screen demisting
	Desempañado de la luna trasera	Sbrinamento del lunotto posteriore	Achterraut verwarming	Bakrutedefroster
1	Dossier fixe	Fast ryglæn	Feststehende Rückenlehne	Fixed seat back
	Respaldo fijo	Schienale fisso	Vaste rugleuning	Fast ryggstöd
2	Dossier réglable	Indstilleligt ryglæn	Einstellbare Rückenlehne	Adjustable seat back
	Respaldo regulable	Schienale regolabile	Verstelbare rugleuning	Ställbart ryggstöd
3	Dossier inclinable (couchette)	Indstilleligt ryglæn (sovebeslag)	Liegesitze	Reclining seat back (travel bed)
	Respaldo inclinable (asiento transformable en cama)	Schienale inclinabile (posizione "cuccetta")	Verstelbare rugleuning (slaapstoelen)	Fällbart ryggstöd
4	Banquette avant	Bænksæde	Mit vorderer Sitzbank	Front bench seat
	Banqueta delantera	Sedile anteriore unico	Met voorbank	Hel framsits
5	Sièges avant séparés	Separate forstole	Mit vorderen Einzelsitzen	Separate front seats
	Asientos delanteros separados	Sedili anteriori separati	Met gescheiden voorzittingen	Separata framstolar
6	Dossier rabattable vers l'avant	Nedklappeligt ryglæn		Seat back folds forward
	Respaldo inclinable hacia delante	Schienale ribaltabile in avanti	Rugleuning kan naar voren klappen	
1	Acier	Stål	Stahl	Steel
	Acero	Acciaio	Staal	Stål
2	Laiton	Messing	Messing	Brass
	Latón	Ottone	Geel koper	Mässing

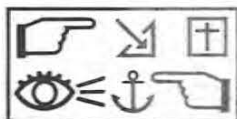

05.07

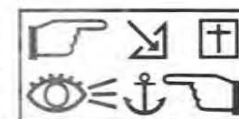

05.07

3	Cuivre	Kobber	Kupfer	Copper
	Cobre	Rame	Rood koper	Koppar
4	Nylon	Nylon	Nylon	Nylon
	Nilón	Nailon	Nylon	Nylon
5	Acier inoxydable	Rustfrit stål	Nichtrostender Stahl	Stainless steel
	Acero inoxidable	Acciaio inossidabile	Roestvrij staal	Rostfrittstål
6	Aluminium	Aluminium	Aluminium	Aluminium
	Aluminio	Alluminio	Aluminium	Aluminium
7	Sellerie Simili	Indtræk af kunstlæder	Kunstlederbezug	Leathercloth upholstery
	Tapizado simili-cuero	Rivestimento similpelle	Kunstleren beklædning	Inredning av konstlæder
8	Sellerie Tissu	Indtræk af stof	Stoffbezug	Cloth upholstery
	Tapizado paño	Rivestimento panno	Stoffen beklædning	Inredning av tyg
9	Percalé	Plasticlærred	Perkal (Baumwollgewebe)	Coated cambric muslin
	Percal	Percalle	Geprepareerd katoen	Plastbehandlad väv
10	Moquette	Tæppestof	Boden- und Sitzverkleidungsplüsch	Carpeting
	Moqueta	Moquette	Pluche-weefsel	Plysch
11	Feutre	Filt	Filz	Felt
	Fieltro	Feltro	Vilt	Filt
12	Toile à bâche	Presenning	Planenstoff	Tilt canvas
	Lona para toldo	Tessuto per tendone	Zeildoek voor huif	Presenningsväv
13	Sellerie cuir	Indtræk af læder	Lederbezug	Leather upholstery
	Tapizado cuero	Rivestimento pelle	Leren beklædning	Inredning av läder
14	Fonte	Støbt	Guss	Cast
	Fundición	Ghisa	Gegoten	Gjutjärn

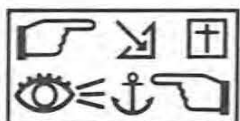

05.08

05.08



	Repère couleur	Farvemærke	Farbmarkierung	Colour mark
	Señal color	Riferimento colore	Kleurmerkteken	Färgmärkning
1	Chrome	Sølvbronze	Chrom	Chrome
	Cromo	Cromo	Chroom	Krom
2	Or	Guldbronze	Gold	Gold
	Oro	Oro	Goudkleurig	Guld
3	Blanc	Hvid	Weiss	White
	Blanco	Bianco	Wit	Vit
4	Gris moyen	Mellemgrå	Mittelgrau	Medium grey
	Gris intermedio	Grigio medio	Grijs	Grå
5	Noir	Sort	Schwarz	Black
	Negro	Nero	Zwart	Svart
6	Bleu moyen	Mellemblå	Mittelblau	Medium blue
	Azul intermedio	Blu medio	Middel blauw	Mellanblå
7	Bleu clair	Lyseblå	Hellblau	Light blue
	Azul claro	Blu chiaro	Licht blauw	Ljusblå
8	Vert moyen	Mellemgrøn	Mittelgrün	Medium green
	Verde intermedio	Verde medio	Middel groen	Mellangrøn
9	Vert clair	Lysegrøn	Hellgrün	Light green
	Verde claro	Verde chiaro	Licht groen	Ljusgrøn
10	Vert olive	Mørkegrøn	Olivgrün	Olive green
	Verde oliva	Verde oliva	Olijf groen	Olivgrøn
11	Jaune	Gul	Gelb	Yellow
	Amarillo	Giallo	Geel	Gul

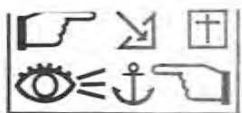

05.09

05.09

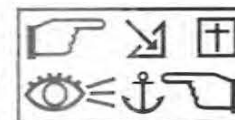

12	Orange	Orange	Orange	Orange
	Naranja	Arancione	Oranje	Apelsinfärgad
13	Marron foncé	Mörkebrun	Dunkelbraun	Dark maroon
	Marrón oscuro	Marrone scuro	Donker bruin	Mörkbrun
14	Marron clair	Lysebrun	Hellbraun	Light maroon
	Marrón claro	Marrone chiaro	Licht bruin	Ljusbrun
15	Beige moyen	Mellembeige	Mittelbeige	Medium beige
	Beige intermedio	Beige medio	Beige	Beige
16	Rouge moyen	Mellemröd	Mittelfrot	Medium red
	Rojo intermedio	Rosso medio	Middel rood	Röd
17	Rose	Lyseröd	Rosa	Pink
	Rosa	Rosa	Rose	Rosa
18	Violet	Violet	Lila	Violet
	Violeta	Viola	Paars	Violett
19	Mauve	Lilla	Fliederfarben	Mauve
	Malva	Lilla	Donker paars	Mauve-färgad
20	Rouge foncé	Mörkeröd	Dunkelrot	Dark red
	Rojo oscuro	Rosso scuro	Donker rood	Mörkröd
21	Gris clair	Lysegrå	Hellgrau	Light grey
	Gris claro	Grigio chiaro	Licht grijs	
22	Gris foncé	Mörkegrå	Dunkelgrau	Dark grey
	Gris obscuro	Grigio scuro	Donker grijs	
23	Beige clair	Lys beige	Hellbeige	Light beige
	Beige claro	Beige chiaro	Licht beige	

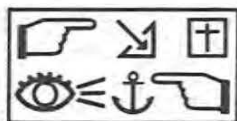

05.10

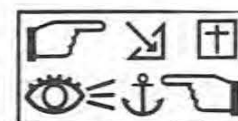

05.10









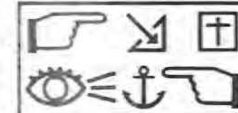



	Beige foncé	Mørk beige	Dunkelbeige	Dark beige
	Beige obscuro	Beige scuro	Donker beige	
	Marron moyen	Mellebrun	Mittelbraun	Medium maroon
	Marrón intermedio	Marrone medio	Bruin	
	Version grand luxe, sièges avant à dossier fixe, sans accoudoir central arrière (L)	Grand luxe udgaven - forstole med fast ryglæn, uden midter-armlæn i bagsædet (L)	Ausführung "Grand Luxe" - Vordere Einzelsitze mit fester Rückenlehne, ohne mittlere Armstütze hinten (L)	Grand luxe version - separate front seats with fixed seatback and no rear centre arm rest. (L)
	Versión gran lujo - asientos delanteros con respaldo fijo, sin recodadero central atrás (L)	Versione gran lusso - sedili anteriori a schienale fisso, senza poggiatesta posteriore centrale (L)	Grand-luxe-uitvoering - voorzittingen met vaste rugleuning, zonder midden-armsteun achterin (L)	Grand luxe - separata framstolar med fast ryggstöd och utan mittersta armstödet bak (L)
	Limousine "Export"	Limousine "Export"	Limousine "Export"	Saloon "Export"
	Limusina "Export"	Renault 4 "Export"	Type "Export"	"Exportmodell"
	Fourgonnette tôlée avec trappe de pavillon	Varevogn, uden sideruder, med tagklap	Fourgonnette mit seitlich geschlossenem Ladekasten, mit Dachluke	Steel side panel van with roof flap
	Furgoneta sin cristales con portezuela en el techo	Furgoncino normale con sportello sul tetto	Gesloten bestelwagen met dakklep	R 4 skåp standard med taklucka
	Fourgonnette vitrée avec trappe de pavillon	Varevogn, med sideruder, med tagklap	Fourgonnette mit seitlich verglastem Ladekasten, mit Dachluke	Side window van with roof flap
	Furgoneta con cristales con portezuela en el techo	Furgoncino con finestrini laterali fissi con sportello sul tetto	Gesloten bestelwagen met zijruiten met dakklep	R 4 skåp med extra fönster och taklucka
	Version grand luxe, siège avant à dossier inclinable tranches intercalaires, avec accoudoir central arrière (TL)	Model Grand Luxe, med indstilleligt ryglæn og midterarmlæn, og med midterarmlæn på bagsædet (TL)	Vordersitze mit verstellbarer Rückenlehne mit in die Rückenlehne zurückklappbarer Armstütze, mit mittlerer Armstütze hinten (TL)	Grand luxe version with reclining front seat backs, and rear centre arm rest (TL)
	Versión gran lujo, asientos delanteros con respaldo inclinable, cubiertas intercalándose en el asiento - Con recodadero central trasero (TL)	Versione gran lusso, sedili anteriori reclinabili e parti intercalari - Con bracciolo centrale posteriore (TL)	Uitvoering "Grand Luxe" met verstelbare rugleuning en opvulstuk tussen de zittingen Wegklapbare armsteun achter (TL)	Grand luxe-utförande, framstolar med justerbart ryggstöd, nedfällbart sitsmellanstycke - Armstöd mitt bak (TL)
	Limousine "Luxe"	Limousine "Luxe"	Limousine "Luxe"	Limousine "Luxe"
	Limusina "Lujo"	Limousine "Lusso"	Limousine "Luxe"	Limousine "Luxe"
	Version toit normal	Version med normalt tag	Mit Normaldach	Standard roof version
	Versión techo normal	Versione tetto normale	Uitvoering met normaal dak	Standard tak
	Version toit ouvrant	Version med soltag	Mit Schiebedach	Sunroof version
	Versión techo corredizo	Versione tetto apribile	Uitvoering met schuifdak	Soltak
	Version lève-vitre mécanique	Version med mekanisk rúdeoptræk	Mit mechanischem Fensterheber	Mechanical window version
	Versión levantalunas mecánico	Versione alzacrystallo meccanico	Uitgerust met mechanische ruitbediening	Mekanisk fönsterhiss
	Version lève-vitre électrique	Version med elektrisk rúdeoptræk	Mit elektrischem Fensterheber	Electric window version
	Versión levantalunas eléctrico	Versione alzacrystallo elettrico	Uitgerust met elektrische ruitbediening	Automatisk fönsterhiss



05.11

05.11





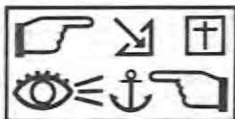



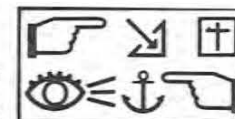



	Version sans desembuage électrique lunette arrière Versión sin desempañado eléctrico de la luna trasera	Model uden varmetråde i bagruden Versione senza sbrinamento elettrico del lunotto posteriore	Ohne elektrische Heckscheibenbeheizung Uitvoering zonder elektrische achterrui-verwarming	Version without electric rear window demister Utförande utan elektrisk bakrutedefroster
	Berline habillage simplifié Berlina revestimiento simplificado	Berline med forenklet indvendigt udstyr Berlina con rivestimento semplificato	Limousine mit vereinfachter innenausstattung Berline in eenvoudige uitvoering	Saloon with simplified trim Kupe, Förenklad utförande
	Berline luxe Berlina de lujo	Berline L Berlina lusso	Limousine "L" Vierdeurs, standaard	L saloon Täckt bil luxe
	Berline tourisme luxe Berlina turismo de lujo	Berline TL Berlina turismo lusso	Limousine "TL" Vierdeurs, luxe	TL saloon Täckt bil tourisme luxe
	Break LN Break LN	Station car LN Break LN	Variable LN Station car LN	LN estate Stations vagn TN
	Break TN Break TN	Station car TN Break TN	Variable TN Station car TN	TN estate Stations vagn TN
	Fourgon à pavillon normal Furgón con el techo normal	Kassevogn med almindeligt tag Furgone a padiglione normale	Kastenwagen mit Normaldach Bestelwagen met normaal dak	Standard roof van Skåp, standardhöjd
	Fourgon à pavillon surélevé Furgón con el techo sobreelevado	Kassevogn med forhøjet tag Furgone a padiglione sopraelevato	Kastenwagen mit überhöhtem Dach Bestelwagen met verhoogd dak	High roof van Skåp, förhöjt tak
	Fourgon à porte battante à pavillon normal Furgón con la puerta normal y el techo normal	Kassevogn med hængslet dør og med almindeligt tag Furgone con portiera a padiglione normale	Kastenwagen mit Flügeltür und Normaldach Bestelwagen met klapdeur en normaal dak	Hinged door van with standard roof Skåp med standardhöjd och gångjärnsupphängda framdörrar
	Fourgon à porte battante à pavillon surélevé Furgón con la puerta normal y el techo sobreelevado	Kassevogn med hængslet dør og med forhøjet tag Furgone con portiera a padiglione sopraelevato	Kastenwagen mit Flügeltür und überhöhtem Dach Bestelwagen met klapdeur en verhoogd dak	Hinged door van with high roof Skåp med förhöjt tak och gångjärnsupphängda framdörrar
	Fourgon à porte coulissante à pavillon normal Furgón con la puerta corrediza y el techo normal	Kassevogn med skydelør og med almindeligt tag Furgone con porta scorrevole a padiglione normale	Kastenwagen mit Schiebetür und Normaldach Bestelwagen met schuifdeur en normaal dak	Sliding door van with standard roof Skåp med standardhöjd och skjutbar framdörr
	Fourgon à porte coulissante à pavillon surélevé Furgón con la puerta corrediza y el techo sobreelevado	Kassevogn med skydedør og med forhøjet tag Furgone con porta scorrevole a padiglione sopraelevato	Kastenwagen mit Schiebetür und überhöhtem Dach Bestelwagen met schuifdeur en verhoogd dak	Sliding door van with high roof Skåp med förhöjt tak och skjutbar framdörr



05.12



05.12

	Microcar à pavillon normal	Minibus med almindeligt tag	Kleinbus mit Normaldach	Standard roof mini bus
	Microbús con el techo normal	Furgone "Microcar" a padiglione normale	Microbus met normaal dak	Minibuss, standardhöjd
	Microcar à pavillon surélevé	Minibus med forhøjet tag	Kleinbus mit überhöhtem Dach	High roof mini-bus
	Microbús con el techo sobreelevado	Furgone "Microcar" a padiglione sopraelevato	Microbus met verhoogd dak	Minibuss med förhöjt tak
	Voiture particulière pour usage commercial à pavillon normal	Personvogn til handelsbrug med almindeligt tag	Kombinationswagen mit Normaldach	Private car for commercial use with standard roof
	Coche particular de utilización comercial con el techo normal	Vettura ad uso commerciale a padiglione normale	Wagen, speciaal voor commercieel gebruik met normaal dak	Kombinerad person och skäpvagn standardhöjd
	Voiture particulière pour usage commercial à pavillon surélevé	Personvogn til handelsbrug med forhøjet tag	Kombinationswagen mit überhöhtem Dach	Private car for commercial use high with roof
	Coche particular de utilización comercial con el techo sobreelevado	Vettura ad uso commerciale a padiglione sopraelevato	Wagen, speciaal voor commercieel gebruik met verhoogd dak	Kombinerad person och skäpvagn med förhöjt tak
	Ambulance	Ambulance	Krankenwagen	Ambulance
	Ambulancia	Autolettiga	Ambulance	Ambulans
	Plateau nu	Pick-up	Pritschenwagen	Platform only
	Plataforma desnuda	Piattaforma nuda	Platte laadbak	Pick-up
	Plateau tous types	Pick-up, alle typer	Pritschenwagen alle Typen	Platform- all types
	Plataforma todos los tipos	Piattaforma tutti i tipi	Laadbak, alle typen	Pick-up samtliga typer
	Plateau à ridelles	Pick-up, med sidefjæle	Pritsche mit Spriegein	Hinged sided platform
	Plataforma con barandillas	Piattaforma con fiancate ribaltabili	Open laadbak met zijschotten	Flak med lämmar
	Plateau bâché	Pick-up med presenning	Pritschenwagen mit Zeltplane und Stahlblechführerhaus	Canvas covered platform with closed cab
	Plataforma con toldo y con cabina metálica	Autocarro con centine e tendone	Laadbak met huif	Fast flak med presenning - stälhytt
	Châssis	Chassis	Fahrgestell	Chassis
	Chasis	Telaio	Chassis	Chassi
	Empattement exprimé en décimètre (dm)	Akselafstand i decimeter (dm)	In Dezimetern (dm) angegebener Radstand	Wheelbase in decimetres (dm)
	Distancia entre los ejes en decímetros (dm)	Passo espresso in decimetri (dm)	Staat de wielbasis in decimeters (dm) aangegeven	Axelavstånd uttryckt i decimeter (dm)
A	Ampère	Ampere	Ampere	Ampere
	Amperio	Ampere	Ampère	Ampere

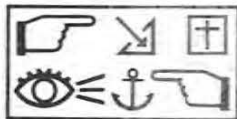

05.13

05.13

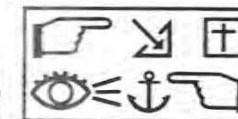

Ah	Ampère-heure	Amperetimer	Amperestunde	Amp./hour
	Amperio-hora	Ampere-ora	Ampère-uur	Ampère-timmar
ISO	International Standardisation Organisation	International Standardiserings organisation	International Standardisation Organisation	International Standardisation Organisation
	International Standardisation Organisation	International Standardisation Organisation	Internationale Standaardiserings Organisatie	Internationella standardiseringsorganisationen
LUXE	Luxe	Luxe	Luxe	de Luxe
	Lujo	Lusso	Luxe uitvoering	de Luxe
MOD	Suivi du millésime, indique l'année du modèle en attente des chiffres d'application	Følgt af årstal : angiver modellens årgang, hvis serienr. for ændringens indførelse ikke kendes	Gefolgt von der Jahresendziffer bezeichnet den Jahrgang bis zur Bekanntgabe präziser Stichdaten	Followed by year of manufacture : indicates model year pending issue of application numbers
	Seguido del año comercial : indica el año del modelo en espera de las cifras de aplicación	Seguito dal millesimo : indica l'anno del modello in attesa delle cifre di applicazione	Gevolgd door een jaartal : geeft het modeljaar aan als de fabricagenummers nog niet beschikbaar zijn	Atföljd av årtal anger årsmodell i väntan på fabriksnummers
MOT	Moteur	Motor	Motor	Engine
	Motor	Motore	Motor	Motor
SI	Système international	Internationalt system	Internationales System	International system
	Sistema internacional	Sistema internazionale	Internationaal Systeem	Internationellt system
V	Volts	Volt	Volt	Volts
	Voltios	Volt	Volt	Volt
VEH	Véhicule	Vogn	Fahrzeug	Vehicle
	Vehículo	Veicolo	Wagen	Vagn
W	Watt	Watt	Watt	Watt
	Vatio	Watt	Watt	Watt
	Les poids et mesures sont indiqués en système métrique	Vægt og mål er anført efter det metriske system	Gewichte und Längenmasse sind nach dem Dezimalsystem aufgeführt	Weights and measures are in metric units
	Los pesos y medidas se indican en el sistema métrico	I pesi e le misure sono indicati secondo il sistema metrico	Maten en gewichten zijn in metrische waarden opgegeven	Vikt och längd enligt decimal- och metersystem
	Les cotes no suivies de symbole sont en millimètres	Mål uden signaturforklaring er mm	Masse ohne Einheitsangabe sind in Millimetern ausgedrückt	Dimension with no following symbol are in millimetres
	Las cotas no seguidas de símbolo indican milímetros	Le quote non seguite dal simbolo sono in millimetri	De maten waar geen teken achter staat zijn in millimeters	När beteckning saknas är längden angiven i millimeter

05.40

A P.R. 1030

R 1273

05.40

A P.R. 1030

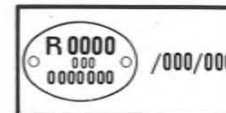

 /100/120

 /600

Origine	Traduction Française	1	2	3	4	5	6
Deutschlands Bundesrepublik	Allemagne (Rép. Féd. d')	120					
France		100					
Great Britain	Grande-Bretagne	600					

Der Franzose

FRANÇAIS

*La plaque ovale est la clef d'utilisation
du catalogue de Pièces de Rechange.*

DANSK

*Den ovale plade er nøglen til
Reservedels-Kataloget.*

DEUTSCH

*Das ovale Schild ist der Schlüssel für
die Handhabung des Ersatzteil-
kataloges.*

ENGLISH

*The oval number plate is the key to
using the spare parts catalogue.*

ESPAÑOL

*La placa oval es la llave que da paso
al buen empleo del catalogo de Piezas
de Repuesto.*

ITALIANO

*La piastrina ovale è la chiave per
l'impiego del catalogo dei pezzi di
ricambio.*

NEDERLANDS

*Het fabricagenummer is de sleutel
van het onderdelenboek.*

SVENSKA

*Den ovala plåten är nyckeln till Er
reservdelskatalog och leder Er till rätt
reservdel.*



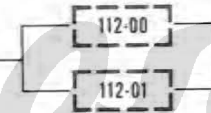
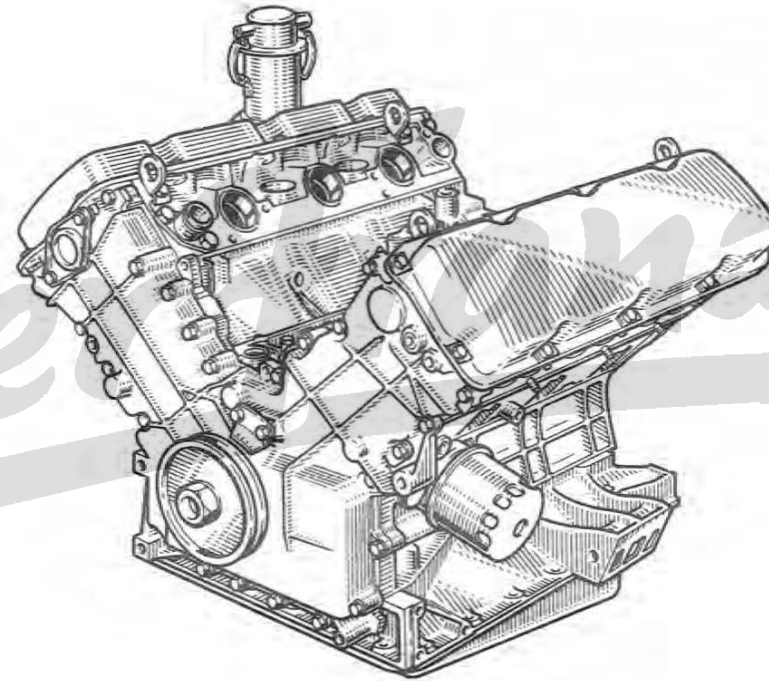

79 00 000 655

Decrease

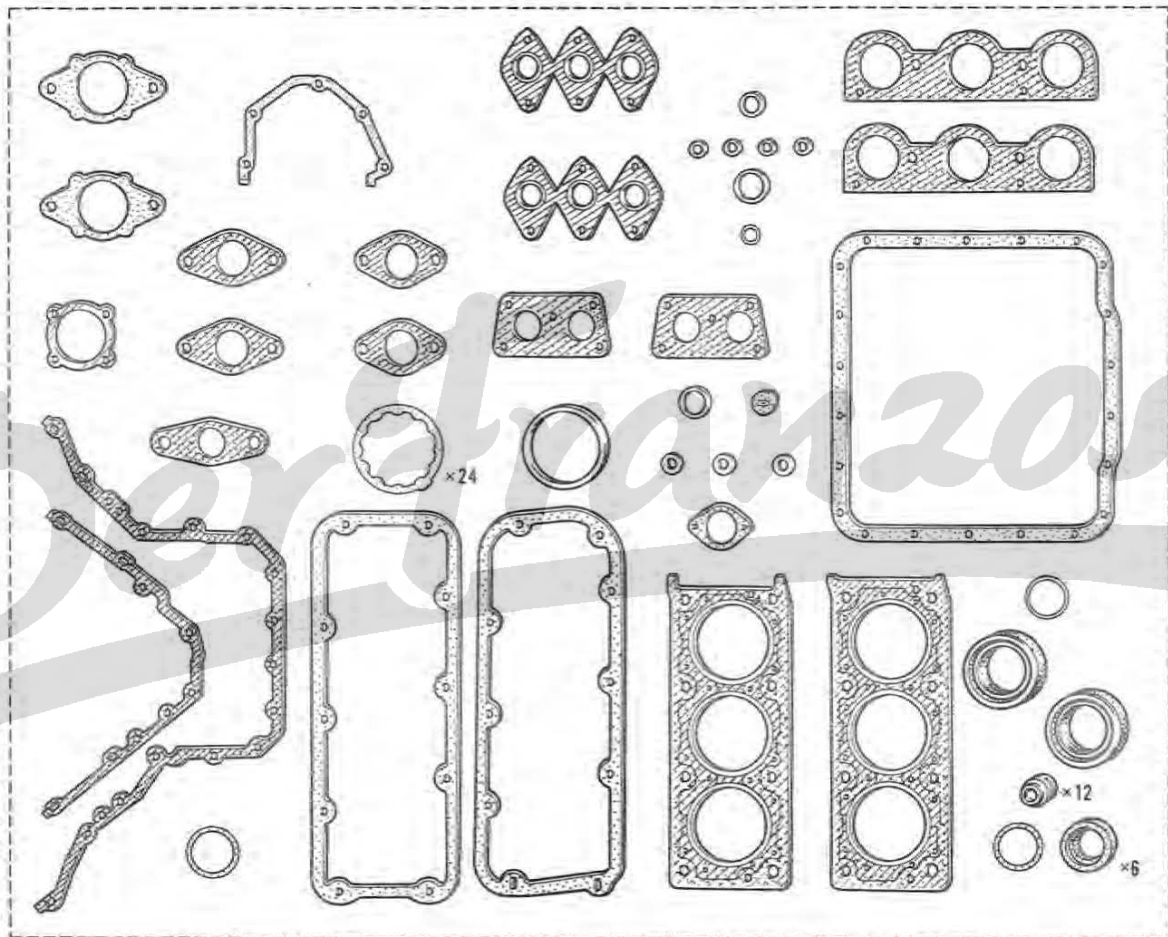
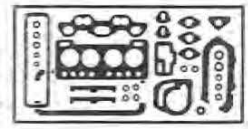

79 00 000 670

10.15

A P.R.1030

10.15

A P.R.1030

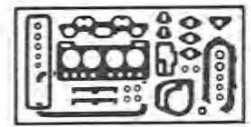

79 00 000 672

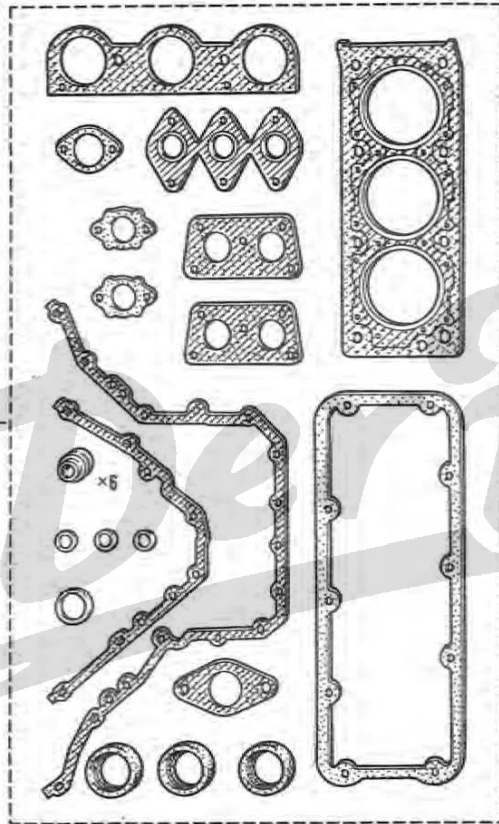

79 00 000 673

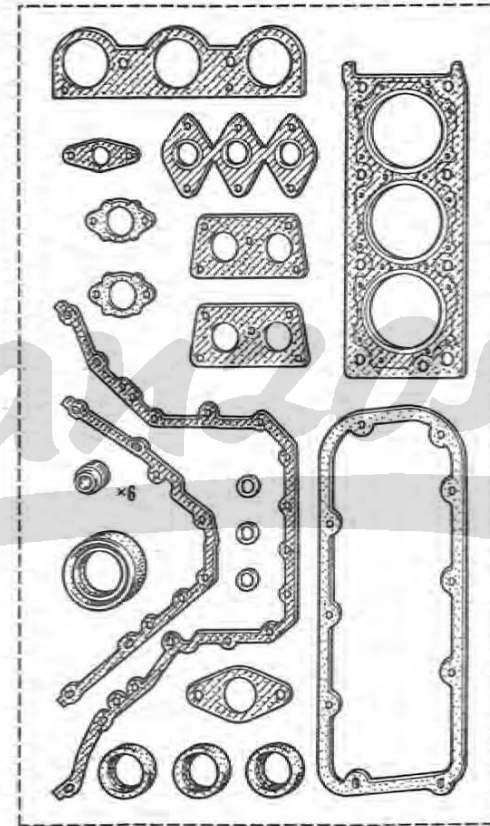

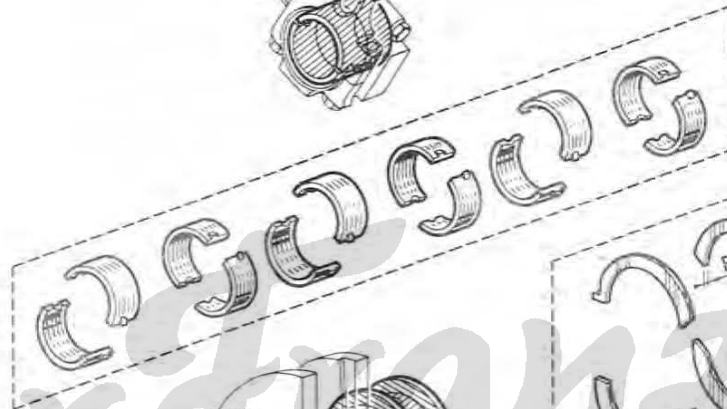
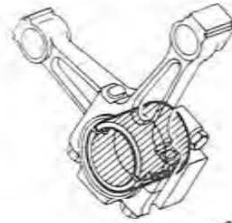

| 79 01 060 645 (A=52,29)
| 79 02 101 378 (A=51,99)

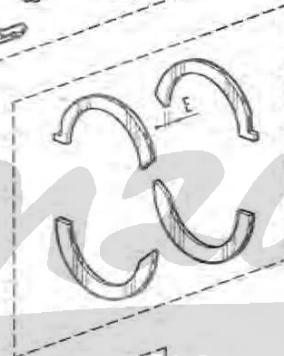

79 01 011 871 (E=2,30 ⇨ 2,35)
79 02 101 375 (E=2,40 ⇨ 2,45)
79 02 101 376 (E=2,45 ⇨ 2,50)
79 02 101 377 (E=2,50 ⇨ 2,55)

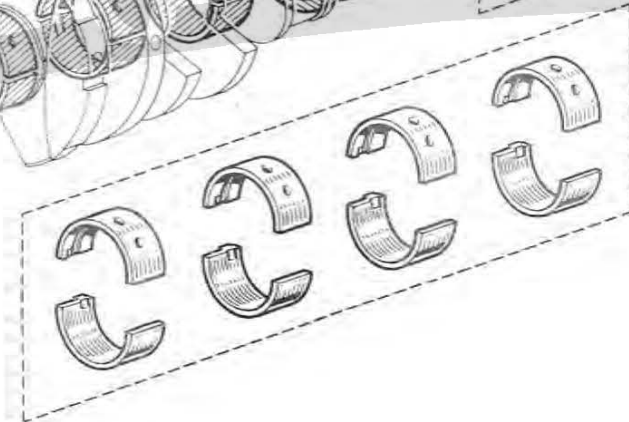
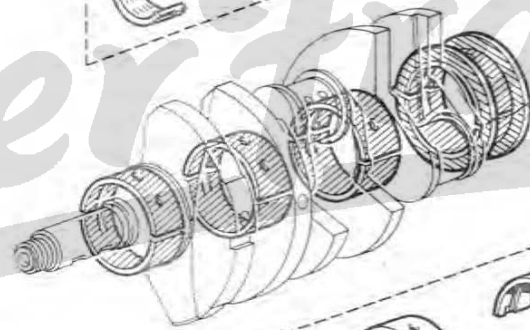

| 79 01 011 321 (A=70,06)
| 79 02 101 374 (A=69,74)

Derivazione

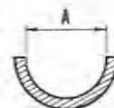

10.40

A P.R.1030

10.40

A P.R.1030

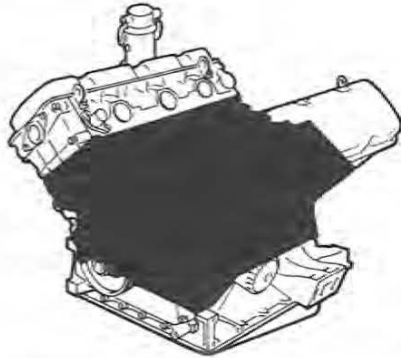
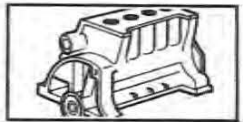

- 78 03 122 000
- 79 03 062 001
- 79 03 075 033
- 79 03 062 003
- 78 03 122 000
- 79 03 062 001
- 79 03 067 023
- 78 03 122 000
- 79 03 062 001
- 77 03 075 015
- 78 30 099 000
- 79 03 067 023
- 79 03 075 028
- 79 03 027 069
- 79 10 245 145
- 79 03 065 057
- 79 03 062 020

- 79 03 075 033
- 79 03 062 003
- 79 03 067 023

- 79 10 245 260 (A=0,07 ⇨ 0,105) 6
- 79 10 245 261 (A=0,085 ⇨ 0,120) 3
- 79 10 245 262 (A=0,105 ⇨ 0,140) 16
- 79 10 245 263 (A=0,130 ⇨ 0,165) 11

- 79 03 057 044
- 77 03 009 065

- 77 03 087 035

- 79 10 245 367
- 79 10 245 368
- 79 03 075 027
- 79 03 067 023
- 79 03 067 009
- 79 03 067 023

- 79 01 010 597

- 79 03 075 033
- 79 03 062 003
- 79 10 245 081



10.50

A P.R.1030

10.50

A P.R.1030

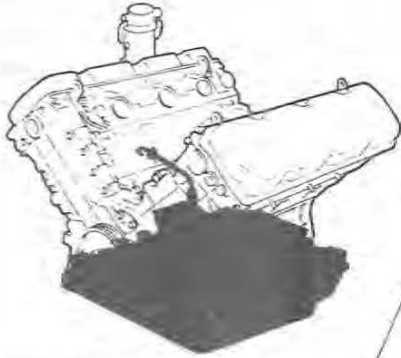
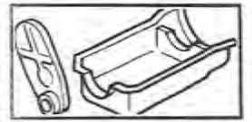

77 00 576 864
77 00 268 151
77 03 001 037
79 03 057 003

77 03 075 015
79 03 053 269
79 03 032 161
79 03 057 005
77 03 001 064

77 03 056 026
77 03 001 491

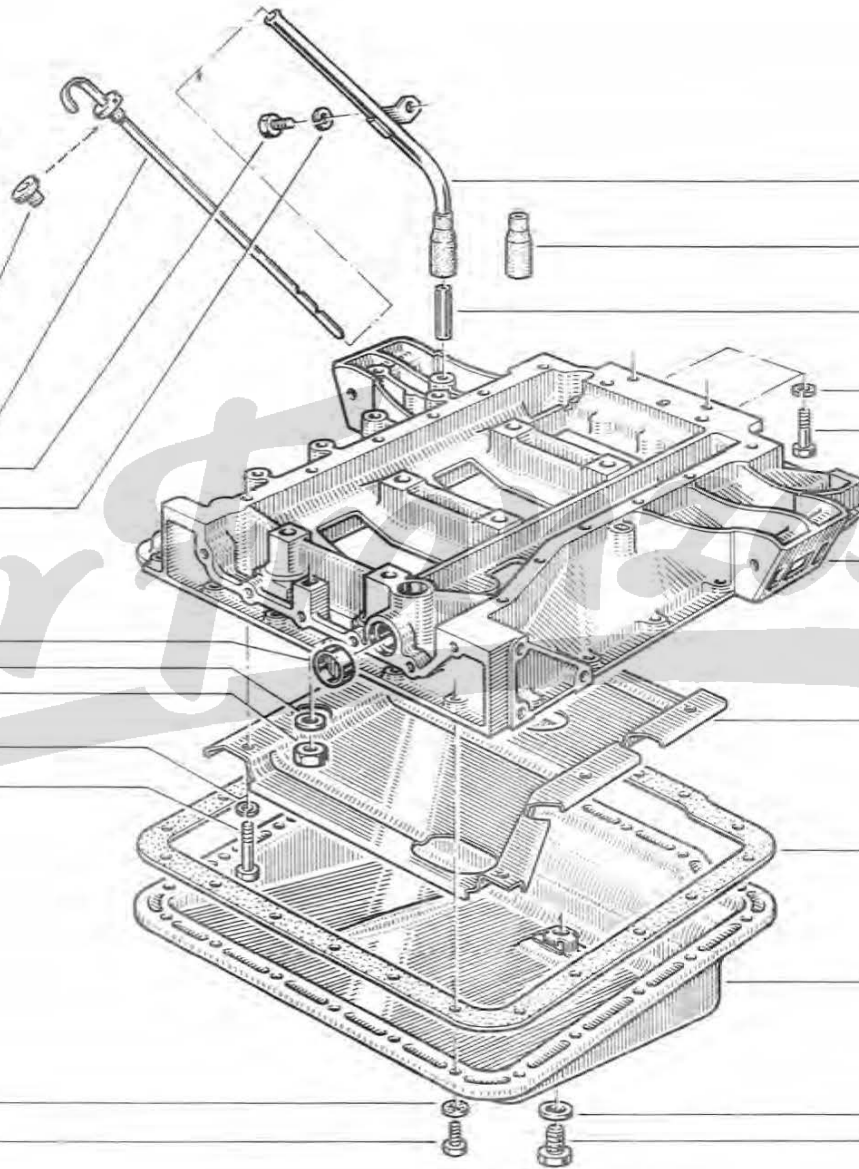

77 00 268 154

77 00 580 324

77 00 268 150

79 03 057 003

77 03 001 042

77 00 268 135

77 00 268 143

77 00 268 142

79 40 009 146

79 03 062 003

79 03 075 033

Derf...se

10.60

A PR 1030

10.60

A PR 1030

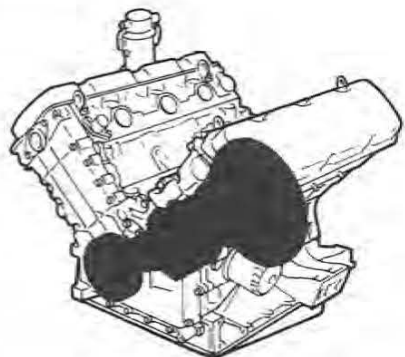
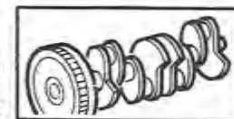

- 79 01 064 031
- (a) 79 01 060 724
- (b) 79 01 060 725

- (a) 79 40 009 120
- (b) 79 01 060 195

- (a) 79 10 245 565
- (b) 79 10 245 868

- 79 03 070 005
- 79 10 245 208
- 79 10 245 110
- 79 10 245 088

- (d) 77 00 268 168
- (e) 77 00 268 109

78 02 188 000

(a) R 1273 ⇄ n° 1 ⇄ n° 250 #

(b) R 1273 ⇄ n° 251 # ⇄ n° ...

(c) K 112-00, K 112-02

(d) K 112-00, K 112-01

(e) K 112-02, K 112-03

79 01 011 055

79 10 245 207 (c)

77 00 576 948 (c)

79 03 067 052 (c)

77 00 268 158 (c)

77 03 090 115 (c)

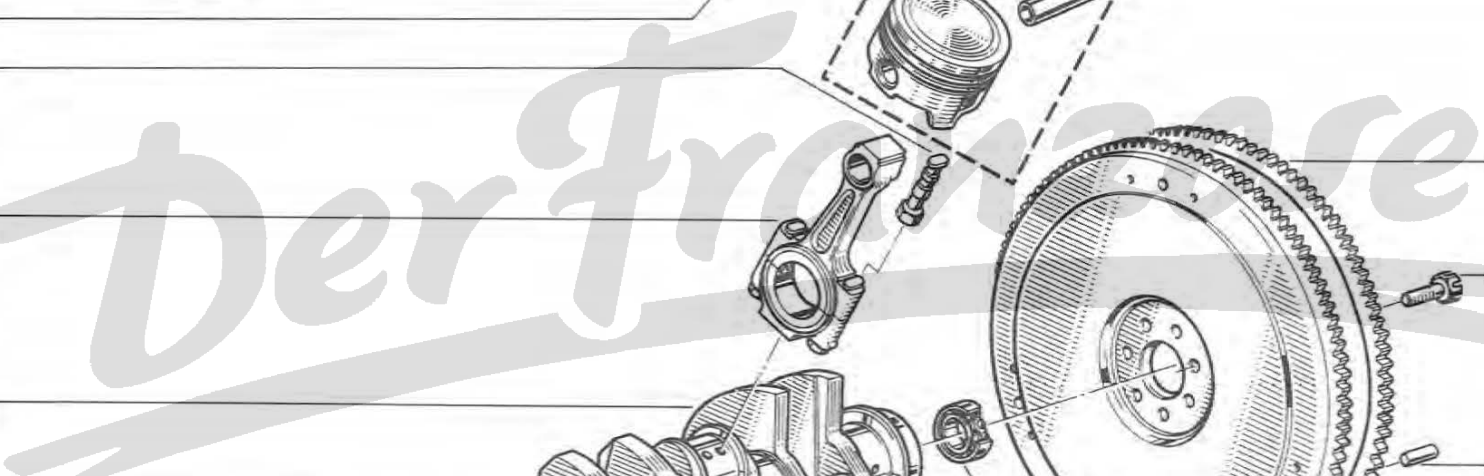

10.70

A PR 1030

10.70

A PR 1030

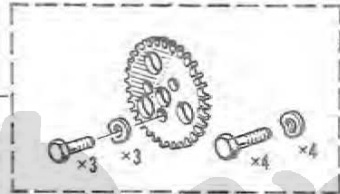
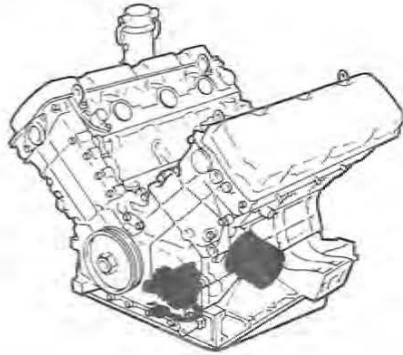

79 01 100 126

79 10 245 573

79 10 004 062

79 03 068 009

79 10 245 061

79 10 245 154

79 03 057 001

77 03 001 018

77 03 001 039

79 03 057 002

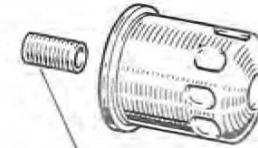

77 00 542 286

77 00 556 153

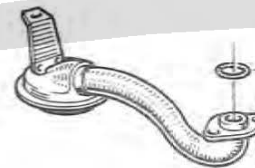

79 03 065 057

77 00 268 075

79 03 057 002

77 03 001 491

Der Franzose

11.01

A P.R.1030

11.01

A P.R.1030

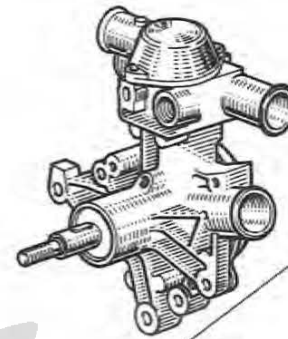
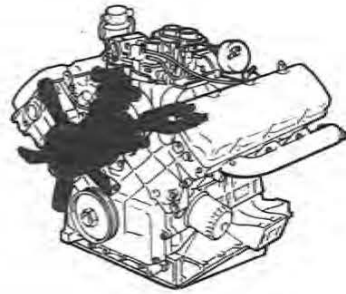
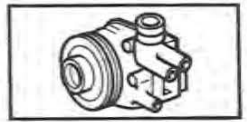

- 77 03 001 040
- 79 03 057 003
- 79 10 245 738
- 79 10 245 278

79 10 245 057

79 10 017 653

79 03 070 004

77 00 268 186

77 00 268 084

77 00 268 139

79 03 039 005

79 03 032 023

74 00 460 530

77 03 001 027

79 00 000 658

78 10 143 000

79 03 057 003

77 03 009 064

77 03 001 044

77 03 001 040

79 03 057 003

79 03 065 015

74 00 269 077

79 10 245 509

79 01 120 708

79 10 245 065

79 03 057 005

77 03 001 059

79 03 032 009

79 03 057 013

77 03 053 032

77 00 268 215

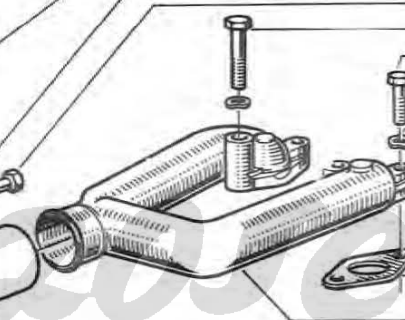
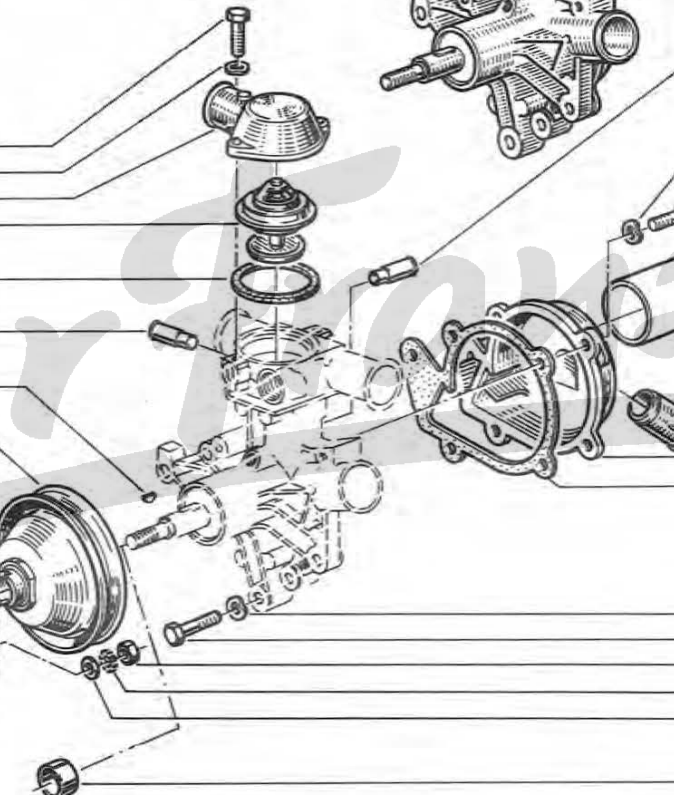
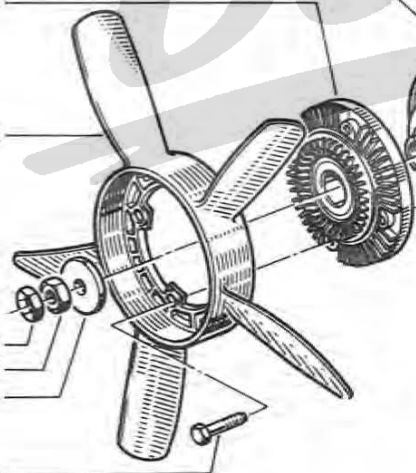

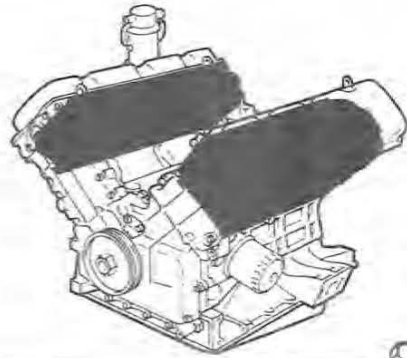
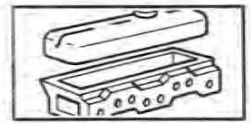

77 03 001 054
79 03 057 005
79 10 245 079

79 03 067 012

79 01 020 211

79 03 075 019

79 10 245 291

[(A=45,43) 79 02 101 348]
[(A=45,63) 79 02 101 349]

[(A=38,93) 79 02 101 351]
[(A=39,13) 79 02 101 352]

78 10 143 000

79 10 245 585

79 10 245 244

79 10 245 243

77 03 027 049

79 10 245 070

79 03 057 013

77 03 001 020

79 10 245 286

79 03 075 003

79 10 245 243

78 12 103 000

[79 02 101 354 (B=13,29)]

[79 02 101 355 (B=13,59)]

78 10 143 000

77 03 087 019

77 03 001 020

79 03 075 003

77 03 061 014

79 01 020 209

78 03 027 059

79 03 075 019

11. 30

A P.R.1030

11. 30

A P.R.1030

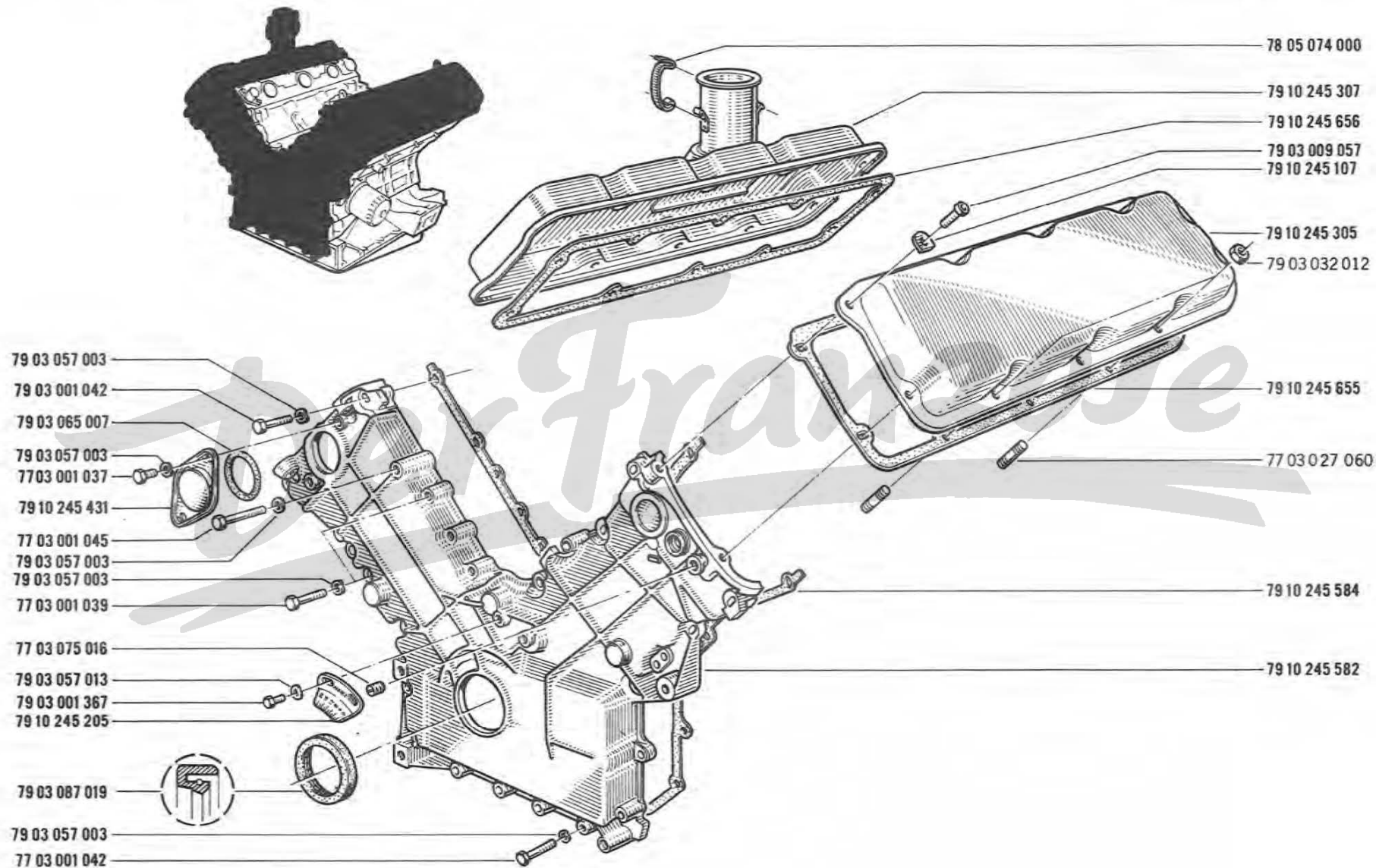
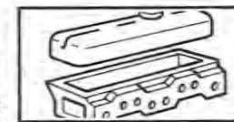

11.40

A P.R.1030

11.40

A P.R.1030

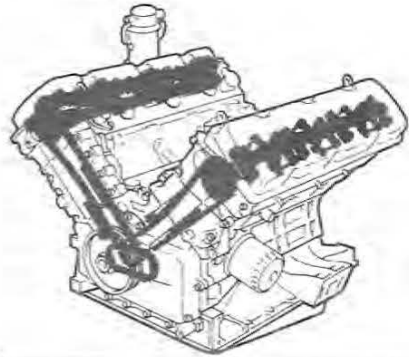
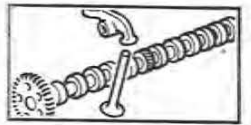

- 79 10 245 162
- 79 10 245 034
- 79 03 066 014
- 79 10 245 412
- 79 10 245 082
- 79 10 245 056

- 79 10 245 301
- 78 12 079 000
- 78 12 080 000
- 78 12 116 000
- 79 03 053 099
- 79 03 053 028
- 79 03 057 001
- 77 03 001 021
- 79 10 004 065
- 79 03 057 001
- 77 03 001 027

- 79 10 245 159
- 79 10 245 073
- 77 03 053 035
- 79 03 001 368

- 79 10 245 548

- 79 10 245 074
- 79 10 245 055 (E=5,35)
- 79 03 032 123
- 79 10 245 083
- 79 10 245 031
- 79 03 053 184
- 79 03 057 001
- 79 10 245 163
- 79 10 245 106 (E=8,22)
- 79 03 067 014
- 79 01 090 330
- 78 12 050 000

- 79 00 000 680

- 79 00 000 681
- 77 03 001 624

- 77 00 268 014

- 77 03 067 042

- 79 10 245 144

- 79 10 245 370

- 79 03 053 039

- 79 03 057 002

- 79 03 001 366

- 79 10 245 301

- 79 10 245 160

- 79 01 084 907

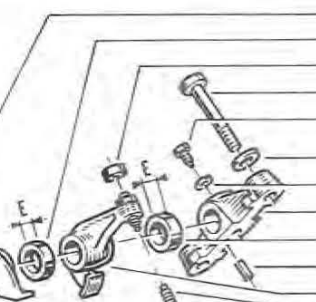
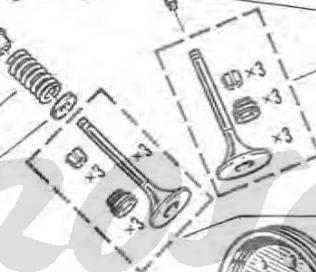
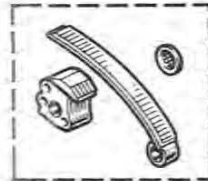

12.01

A P.R.1030

12.01

A P.R.1030

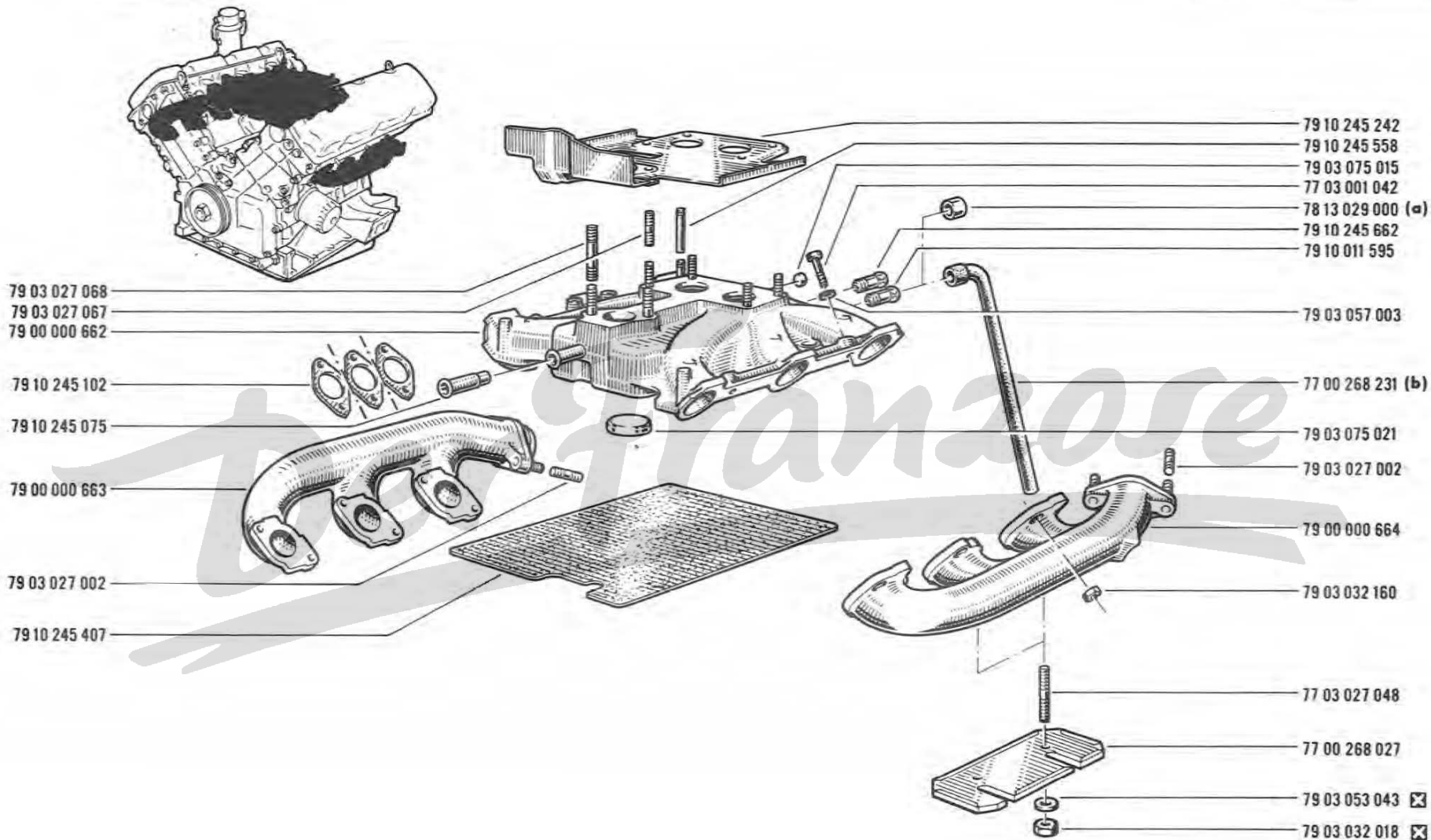
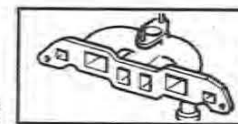

(a)	☐	112-01
(b)	☐	112-00, ☐ 112-02

12.10

A P.R. 1030

12.10

A P.R. 1030

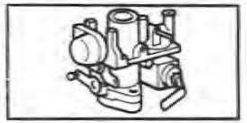

79 03 032 124

79 03 057 005

79 10 245 670

96

79 10 245 589

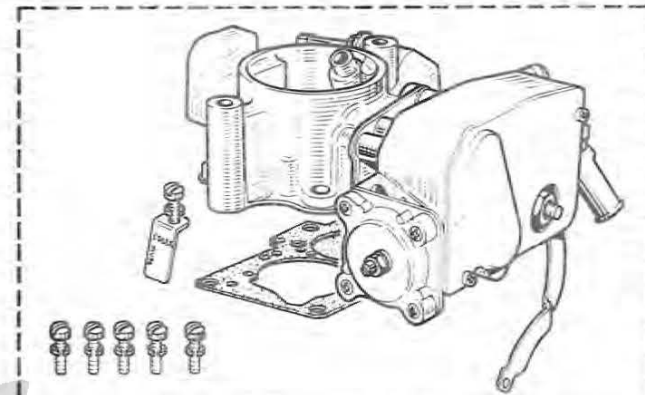
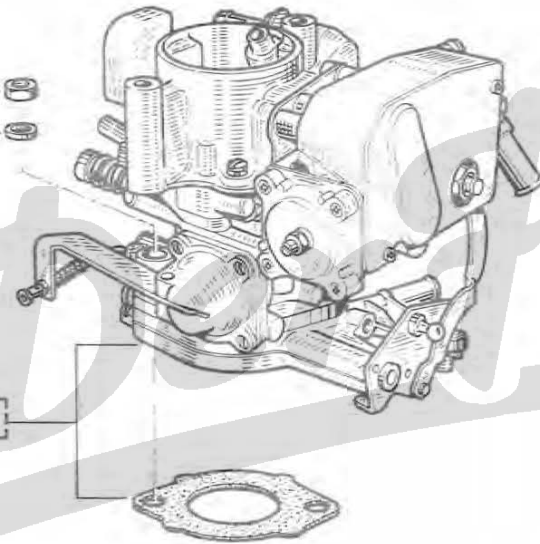

77 01 018 697

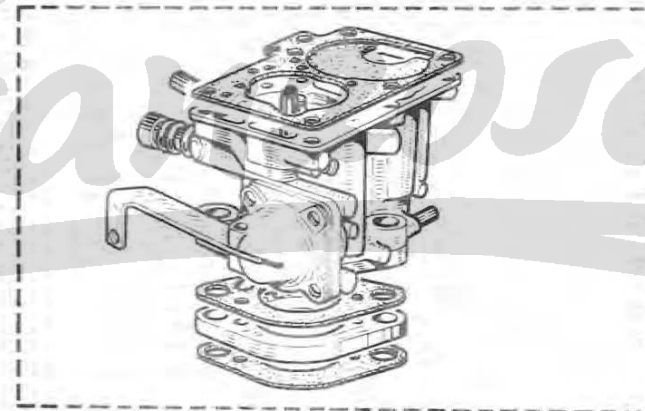

77 01 018 698

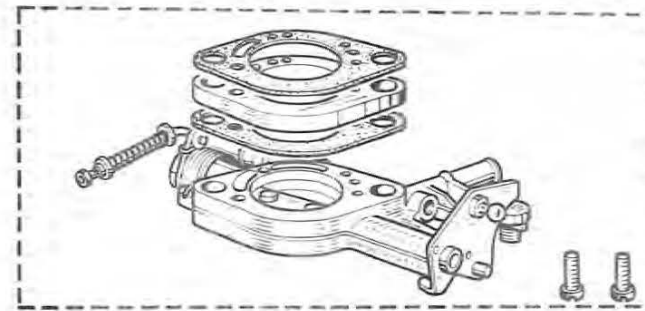

77 01 018 699

12.15
A P.R. 1030

12.15
A P.R. 1030

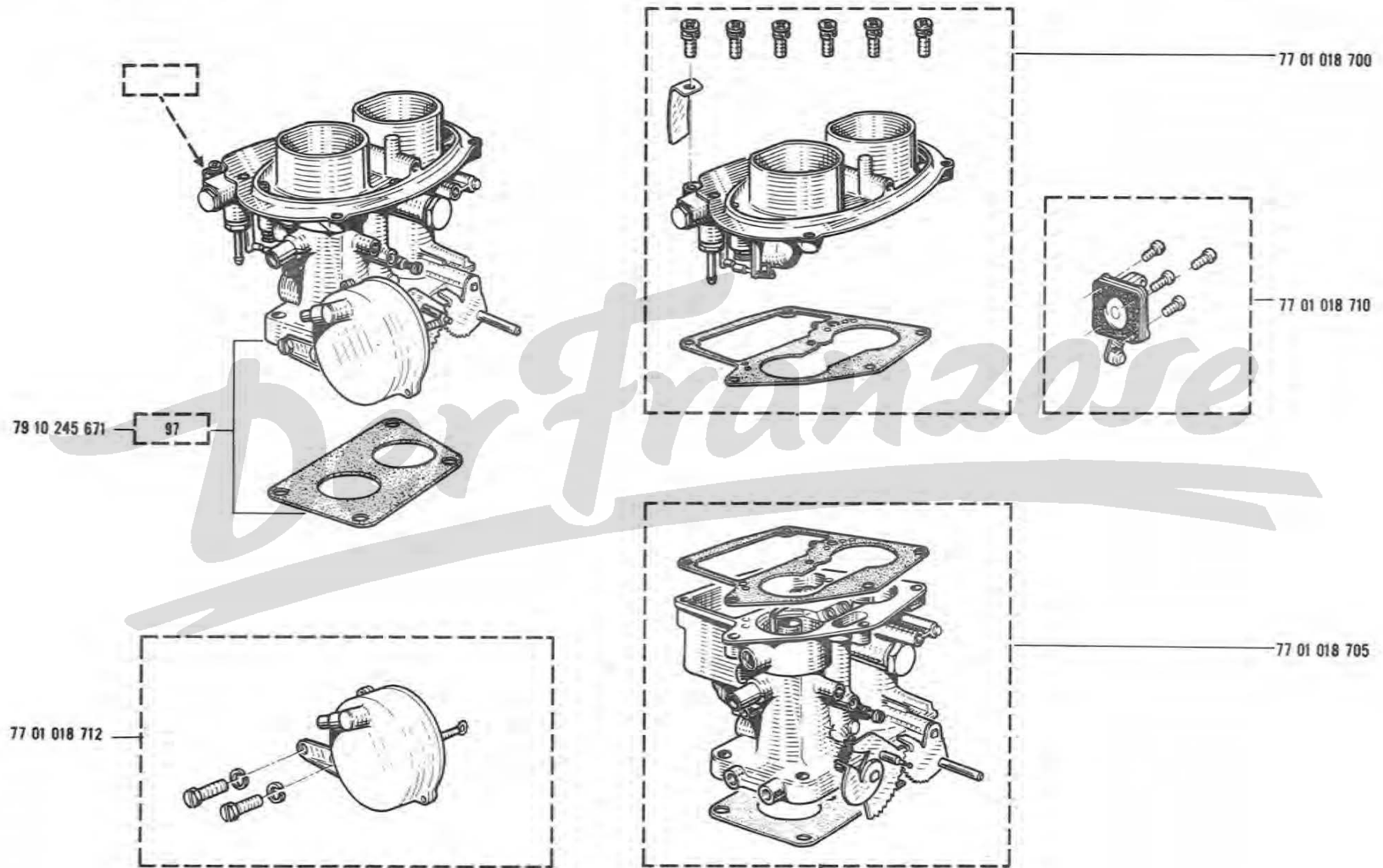
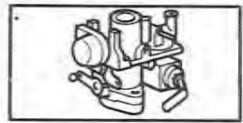

12.35
A PR.1030

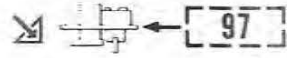

12.35
A PR.1030

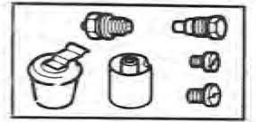

77 01 018 702 [170]

77 01 018 703

08 53 996 444 [145]

08 53 996 444 [145]

77 01 013 502 [47,5]

[60] 77 01 018 707

77 01 003 660

[47,5] 77 01 013 502

Der Franzose

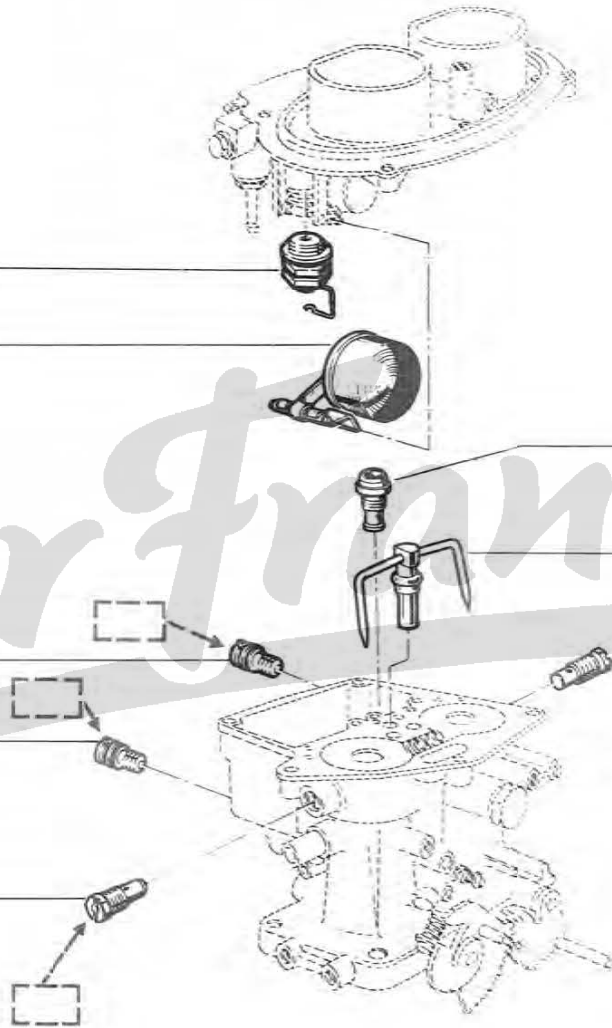

12.45

A P.R.1030



12.45

A P.R.1030



77 01 018 704
77 01 000 921

08 54 522 400

08 55 064 300

08 02 614 900

08 54 625 200

08 54 971 400

77 01 008 752

77 01 018 708

77 01 018 706
08 02 614 900

79 03 032 036

79 03 057 003

79 10 245 014

77 03 055 007

08 54 410 000

77 01 018 701

08 54 822 100

77 01 018 711

77 01 013 533

79 03 001 344

79 03 057 003

79 10 245 217

77 01 018 709

79 10 245 673

79 10 245 672

50 03 057 004

50 03 001 220

Der Franzose

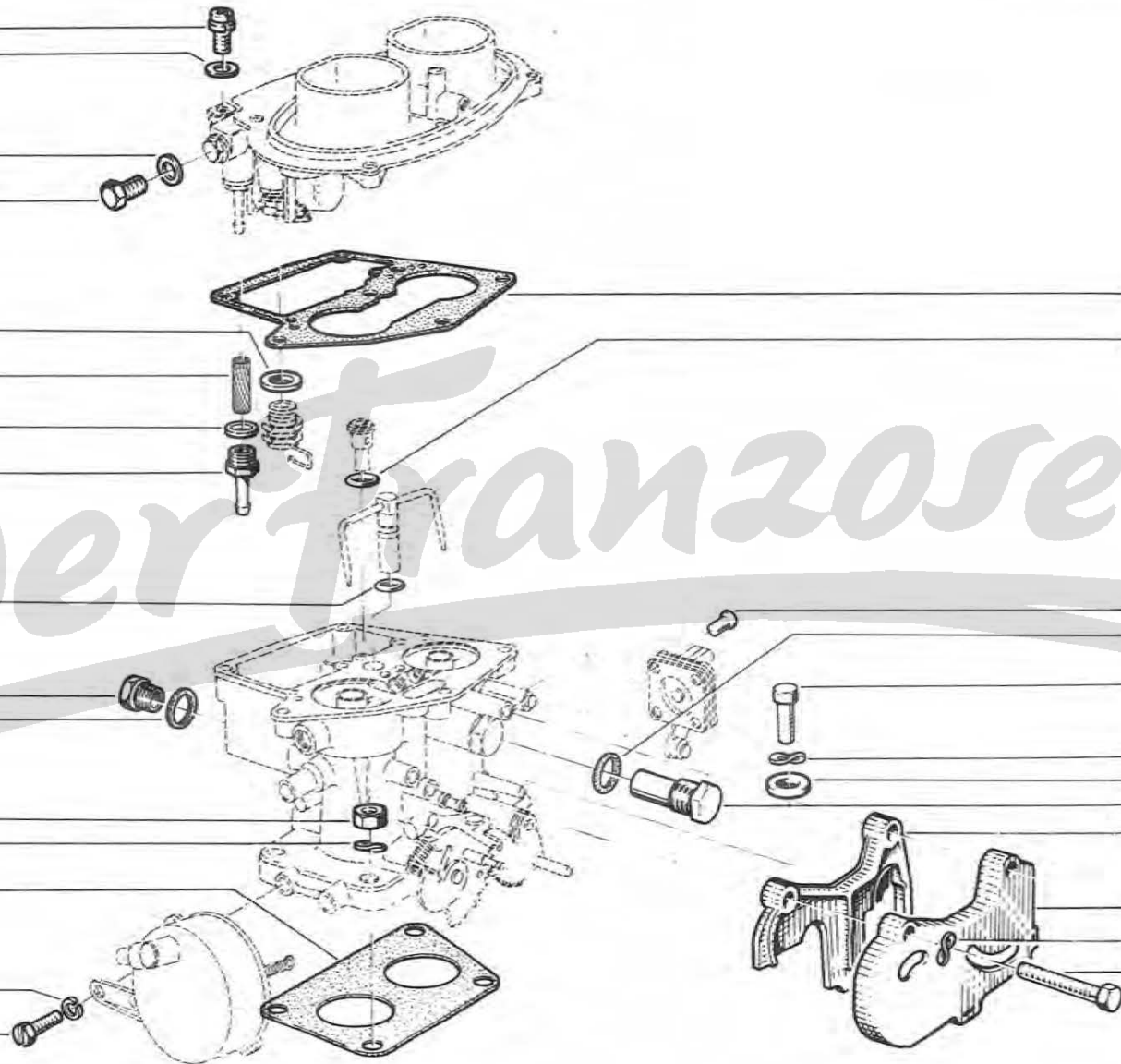

12.50

A P.R.1030

12.50

A P.R.1030

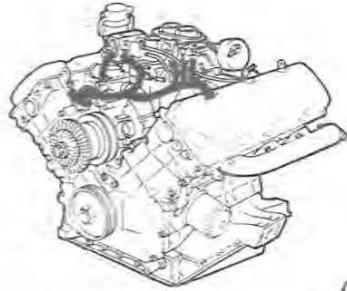
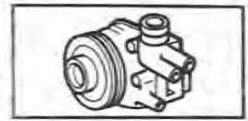

79 10 245 731

79 10 245 465

79 10 245 464

79 10 245 068

77 03 001 039

79 03 057 003

79 10 245 158

79 10 245 069

79 10 245 409

79 10 245 507

79 10 245 095

77 03 001 035

77 00 268 173

79 03 032 012 ☒

79 03 057 003

77 00 268 176

79 10 245 095

77 00 268 165

Bertram Franchise

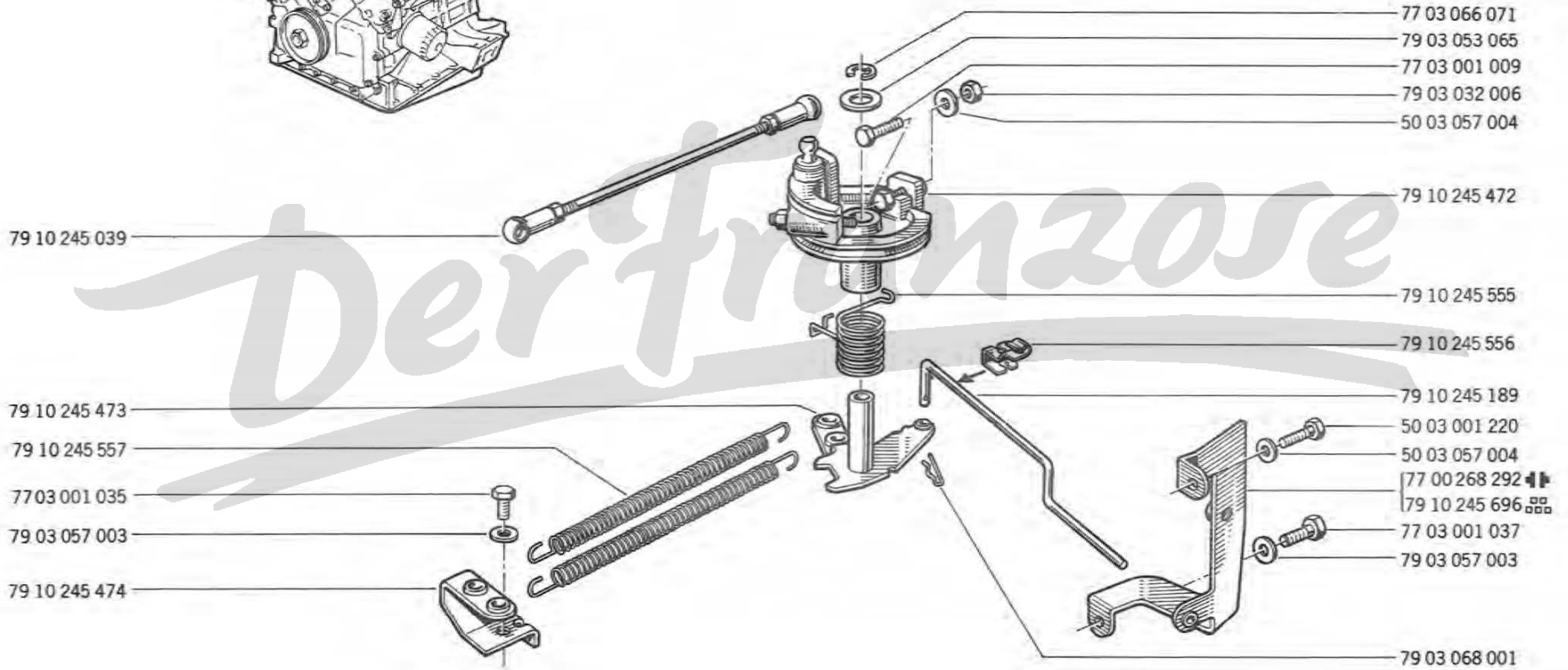
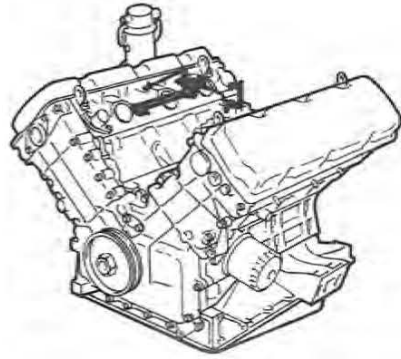

13.01

A P.R.1030

13.01

A P.R.1030

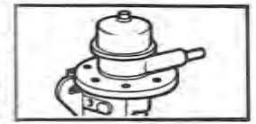

77 01 002 227

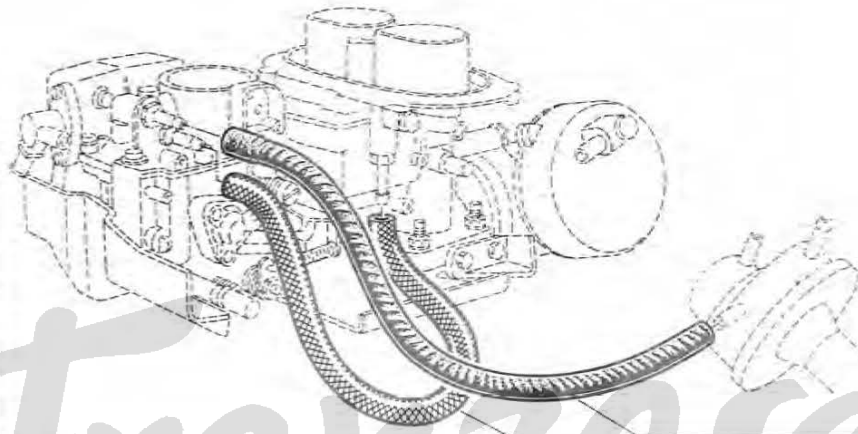

79 10 245 685

79 10 009 147

79 10 245 706

6941

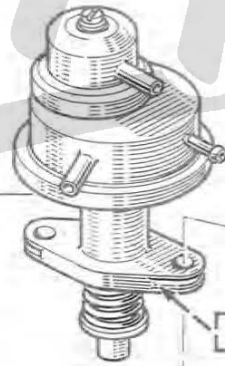

79 03 001 098

79 03 057 003

79 10 245 090

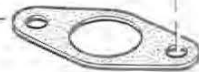

13.20
A P.R.1030

13.20
A P.R.1030

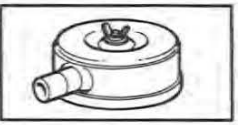

77 03 041 003

79 03 053 028 ☒

77 01 018 606

77 00 268 249

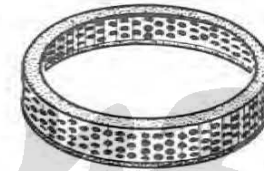

77 01 018 607

79 03 032 009

79 03 053 031

79 03 032 009

79 03 056 039

Der Franzose

79 03 065 030

79 03 027 065

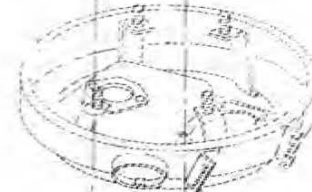

79 10 245 060

79 03 027 065

13.30

A P.R.1030

13.30

A P.R.1030



Der Franzose

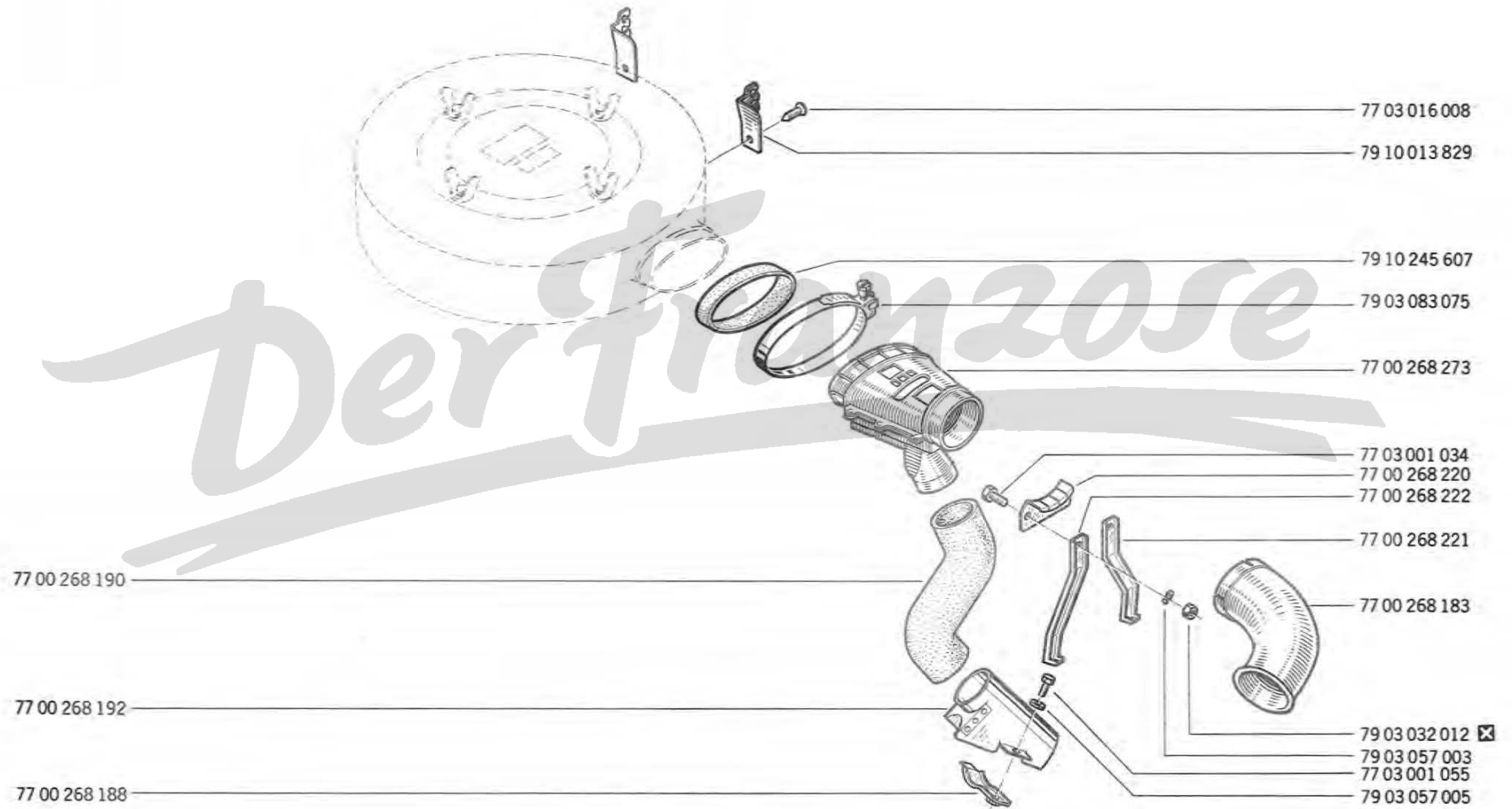

13.50

A P.R.1030

13.50

A P.R.1030

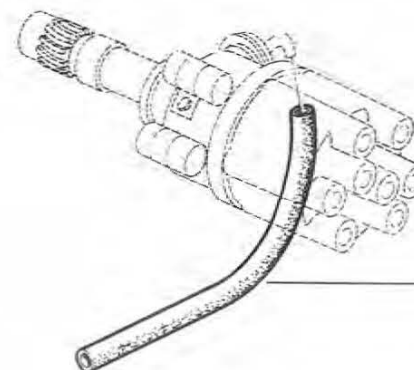
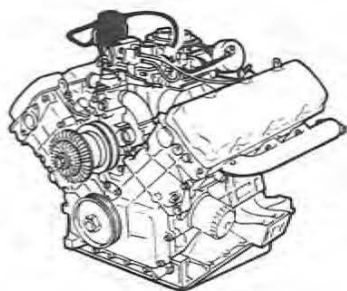
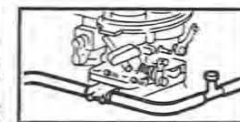

79 10 245 098

79 10 245 538

79 10 245 661

79 10 245 691

78 05 093 000

79 10 009 518

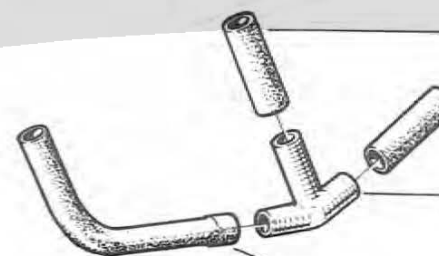
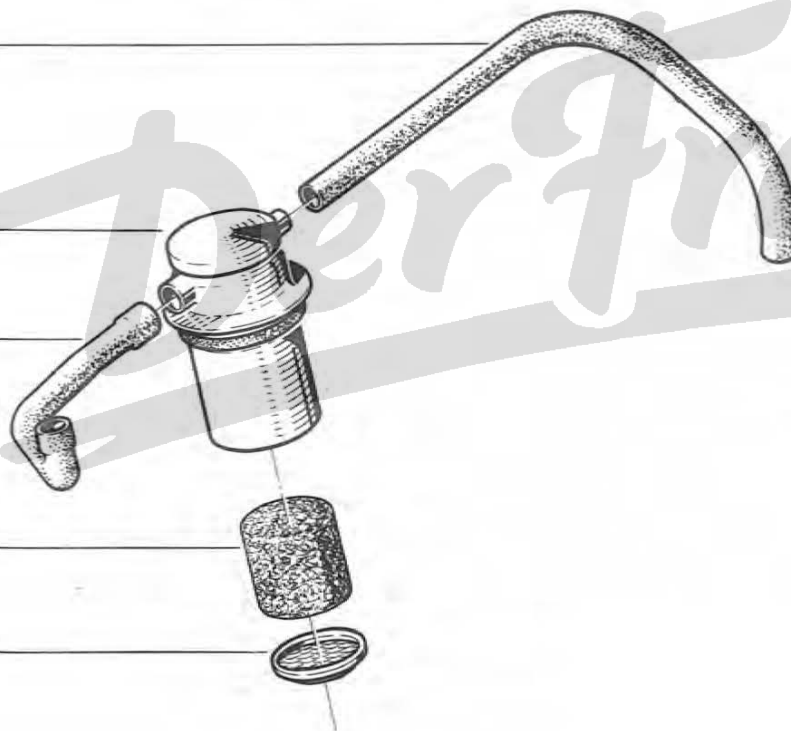

79 10 245 724

79 10 245 724

79 10 245 723

79 10 245 725

13.80

A P.R.1030



13.80

A P.R.1030

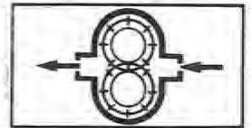

- 77 00 569 103
- 77 00 568 519
- 77 00 584 878

77 01 018 578

77 00 589 468

77 01 018 583

77 00 568 523

77 03 001 055

☒ 77 03 055 011

79 03 053 046

77 00 568 522

☒ 77 03 055 013

77 03 001 663

77 00 586 882

77 03 001 662

☒ 77 03 055 013

77 00 268 296

77 03 001 091

79 03 053 050

☒ 77 03 034 012

77 01 018 582

77 01 018 577

77 01 018 581

77 01 018 580

77 01 018 579

77 01 200 515

77 01 018 578

77 01 200 514

77 01 200 516

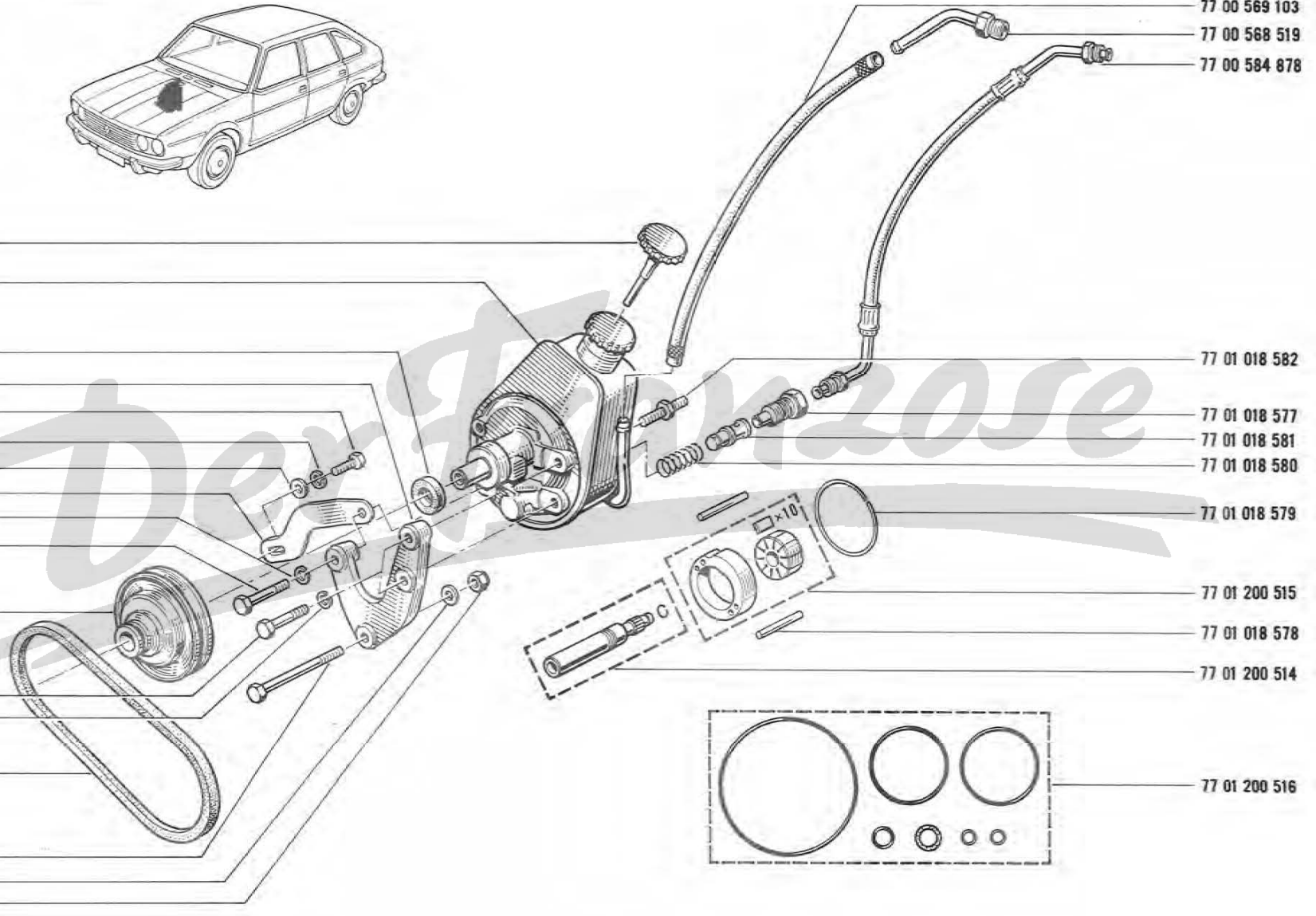

13.90

A P.R.1030

13.90

A P.R.1030

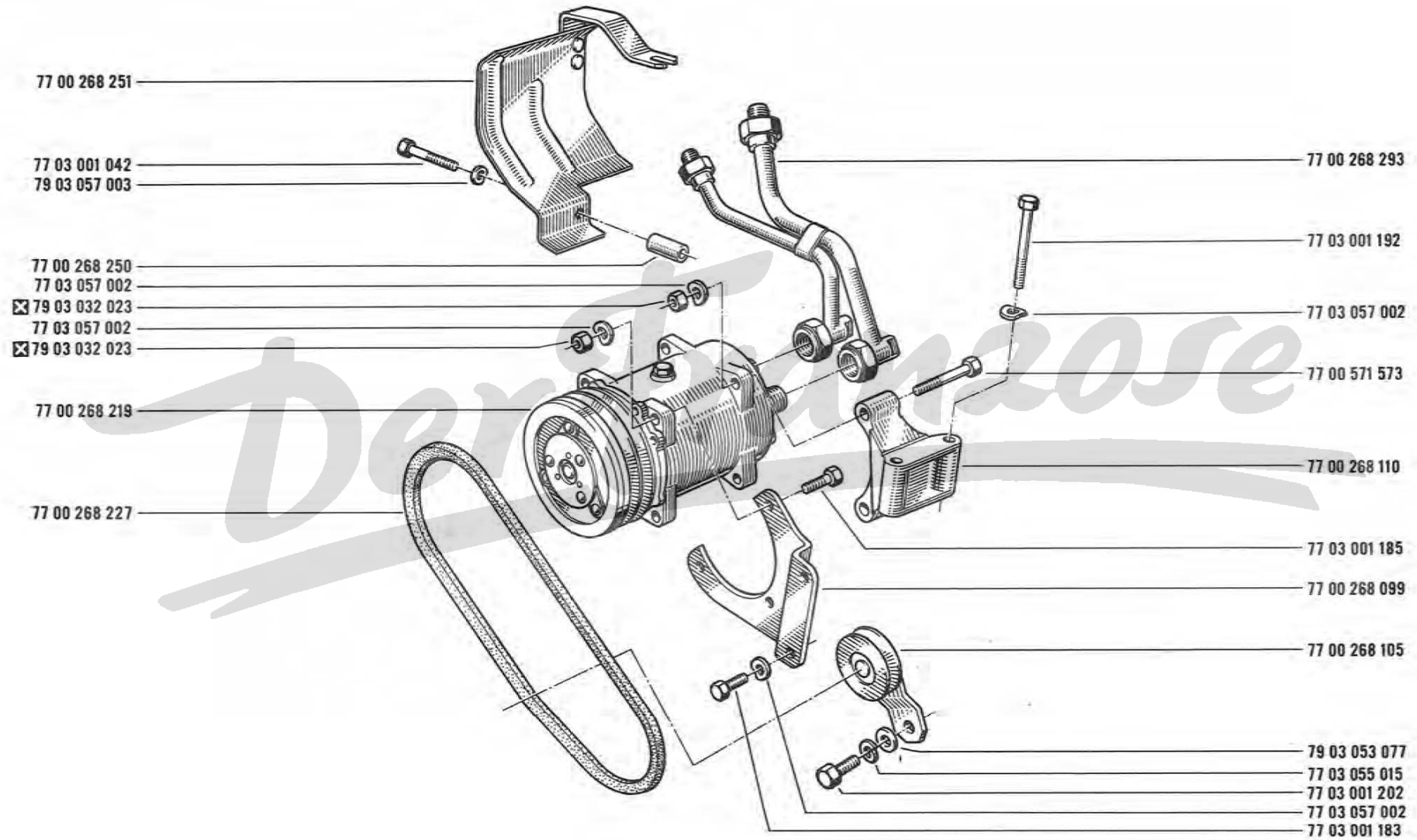
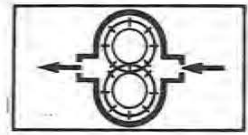

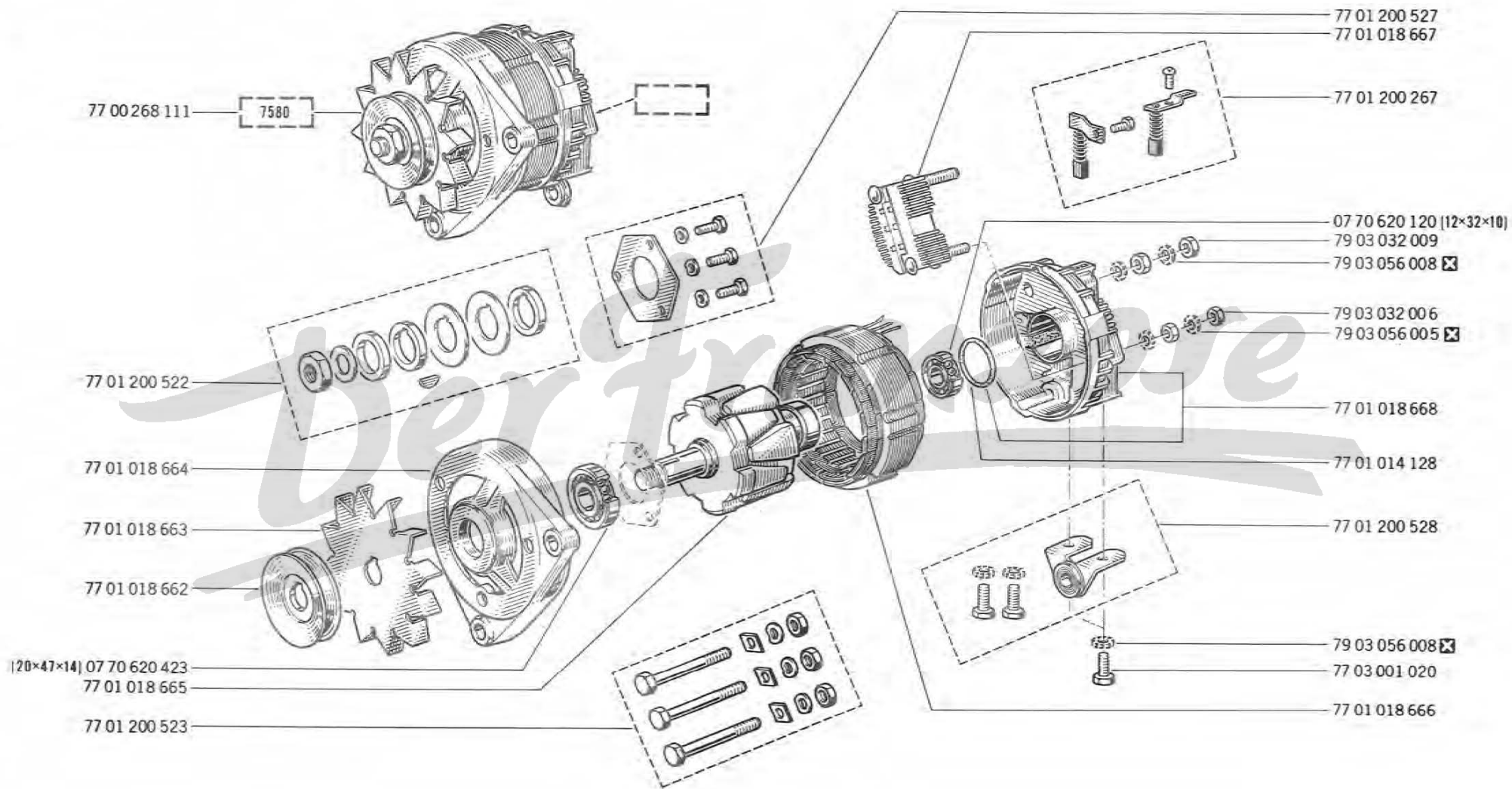
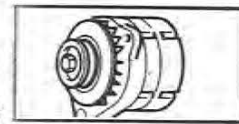

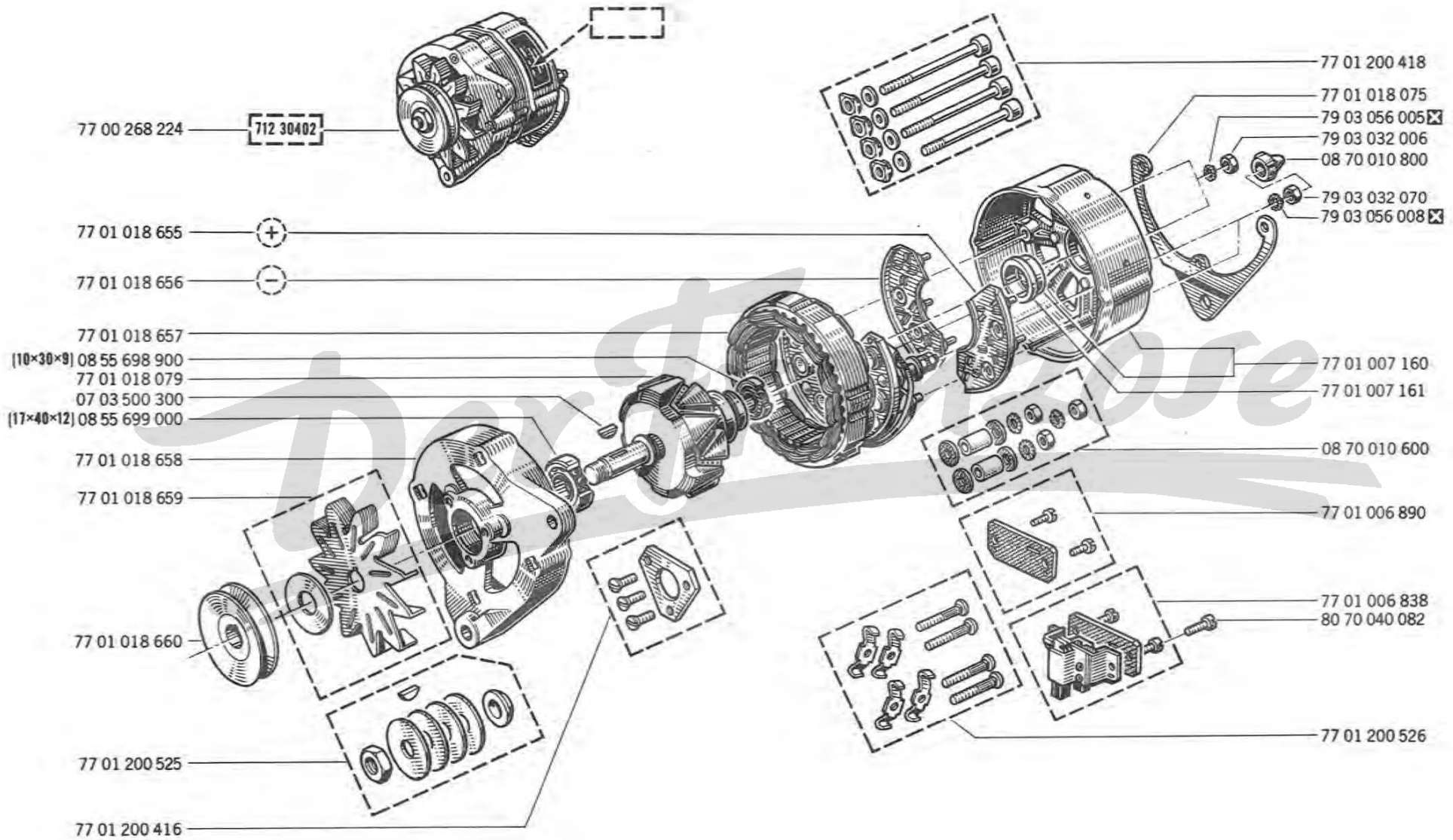
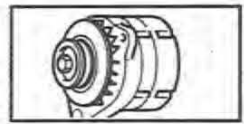

16.20

A PR 1030

16.20

A PR 1030

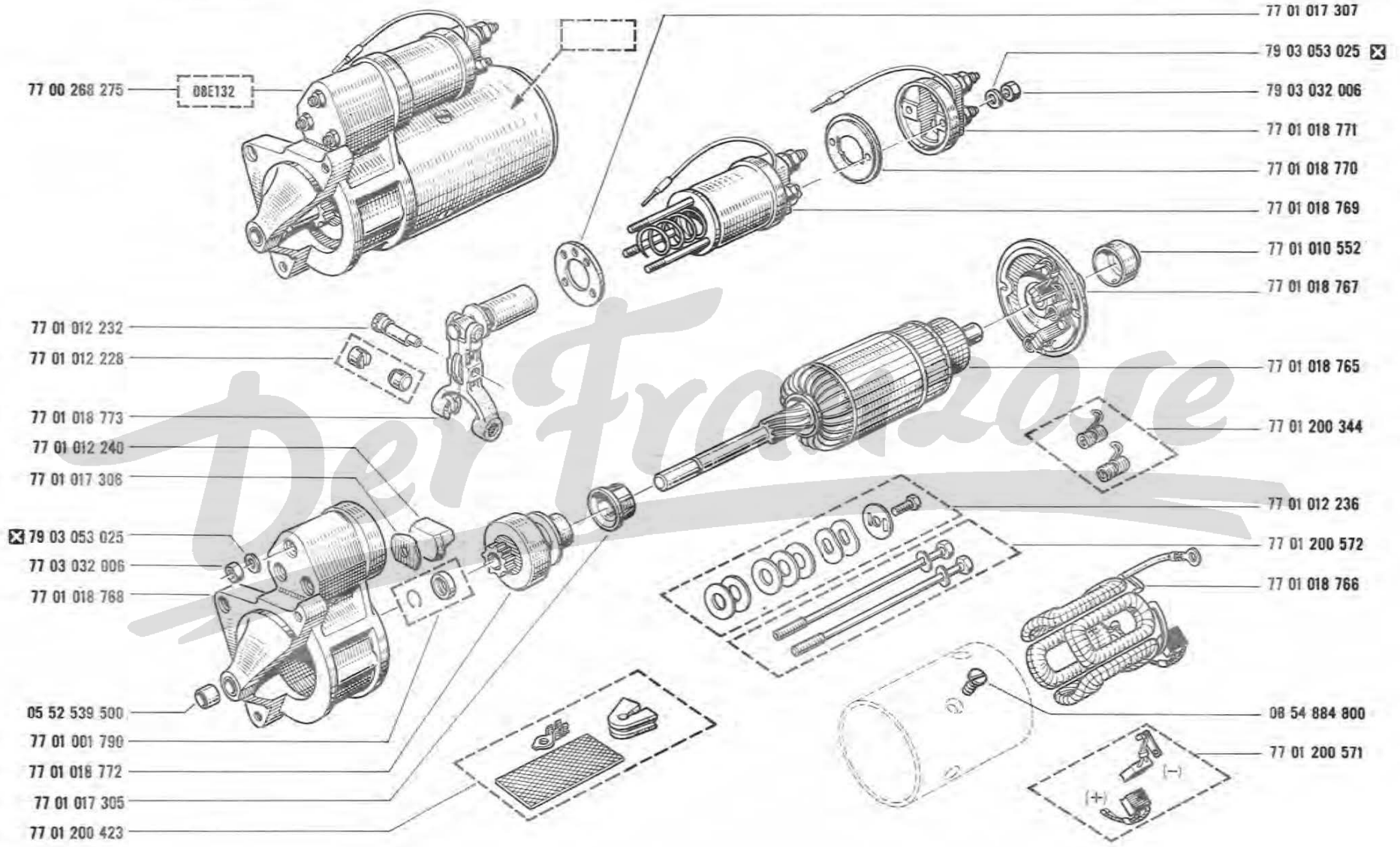
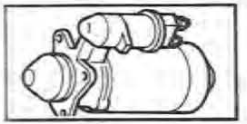

77 00 268 275

Ø8E132

77 01 017 307

79 03 053 025

79 03 032 006

77 01 018 771

77 01 018 770

77 01 018 769

77 01 010 552

77 01 018 767

77 01 012 232

77 01 012 228

77 01 018 765

77 01 018 773

77 01 012 240

77 01 200 344

77 01 017 306

77 01 012 236

79 03 053 025

77 03 032 006

77 01 200 572

77 01 018 768

77 01 018 766

05 52 539 500

08 54 884 800

77 01 001 790

77 01 200 571

77 01 018 772

77 01 017 305

77 01 200 423

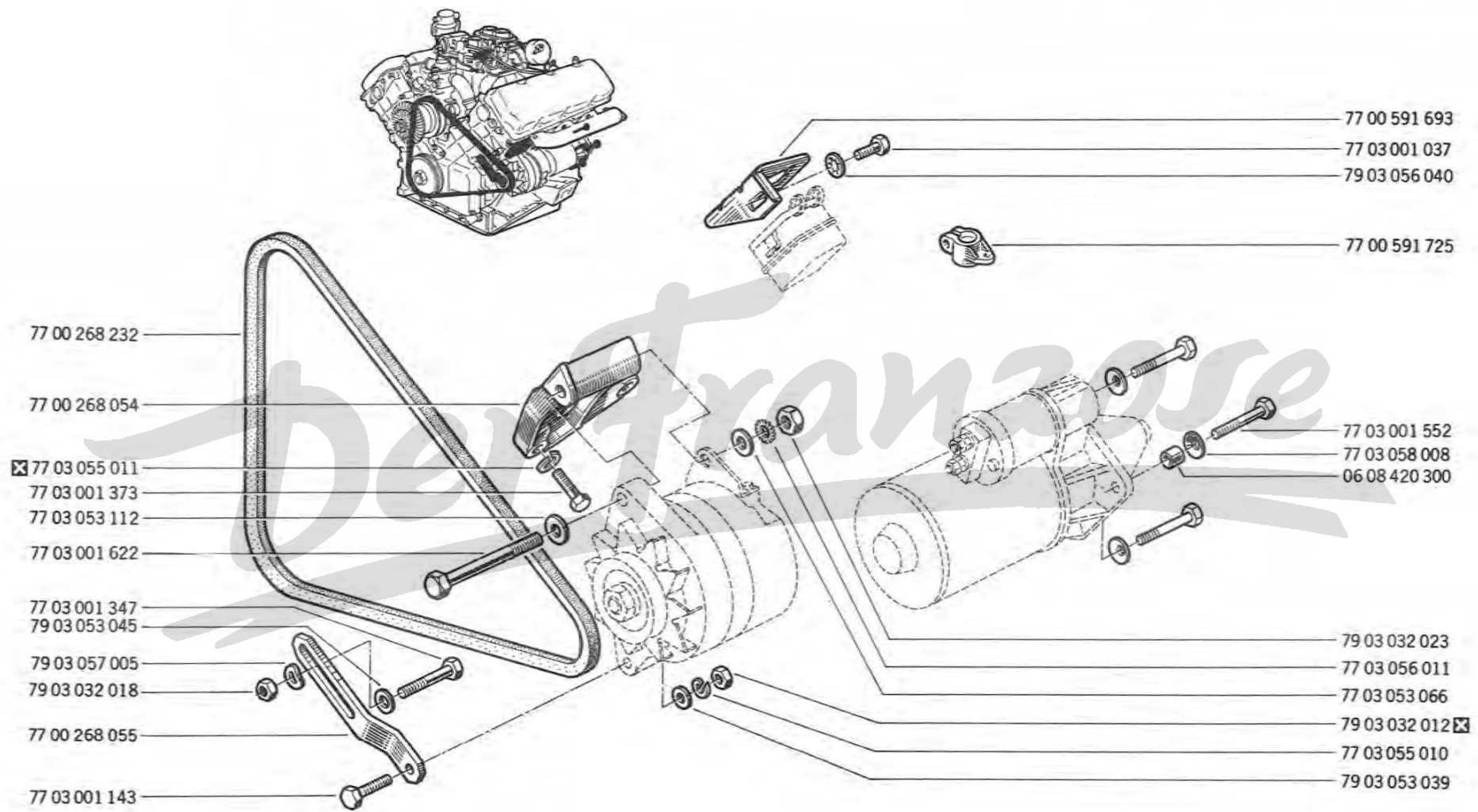
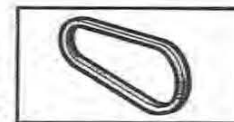

17.01

A P.R. 1030

17.01

A P.R. 1030

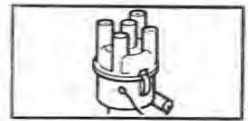

77 01 200 562

77 01 018 727

77 01 018 728

79 10 245 720

08 52 174 300

77 01 018 726

77 01 200 564

77 03 061 013

79 03 032 013

79 03 057 003

77 00 577 010

77 01 012 451

4498

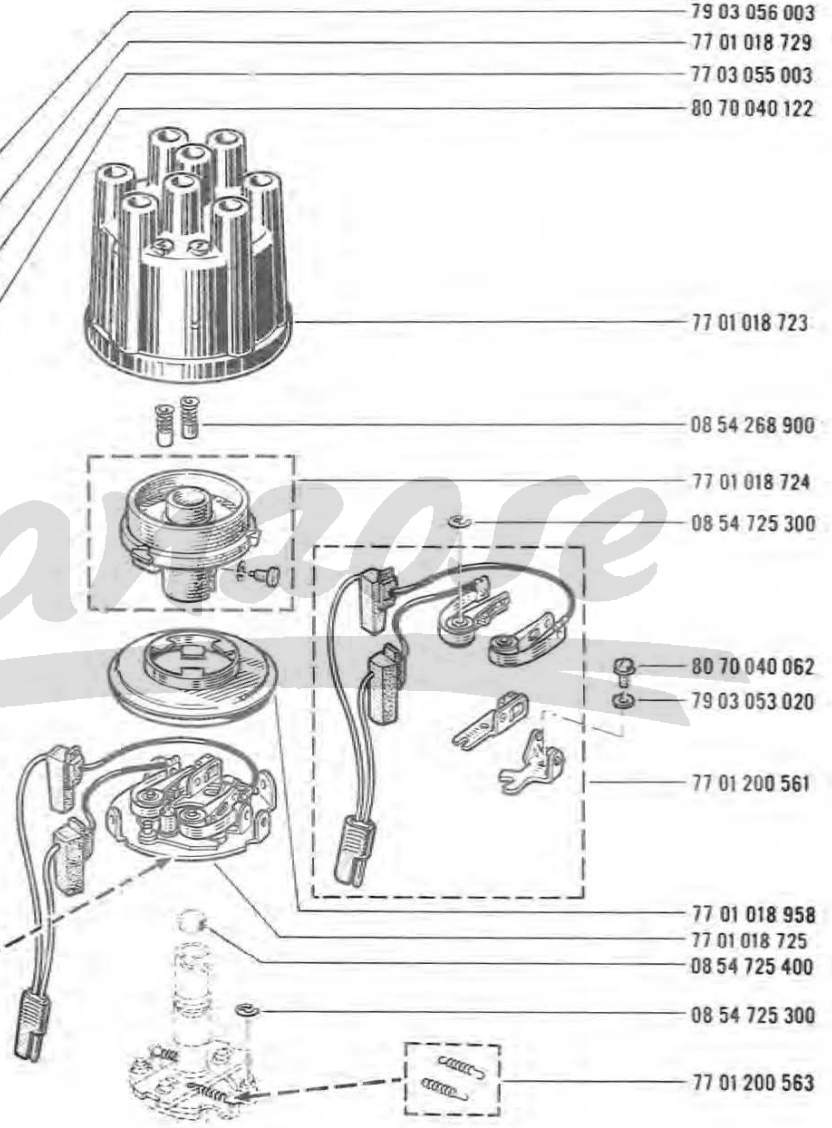
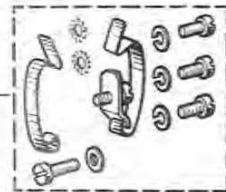

79 03 056 003

77 01 018 729

77 03 055 003

80 70 040 122

77 01 018 723

08 54 268 900

77 01 018 724

08 54 725 300

80 70 040 062

79 03 053 020

77 01 200 561

77 01 018 958

77 01 018 725

08 54 725 400

08 54 725 300

77 01 200 563

17.10

A P.R.1030

17.10

A P.R.1030



77 00 268 172

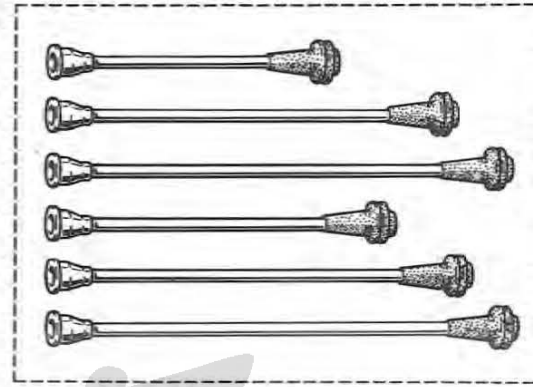
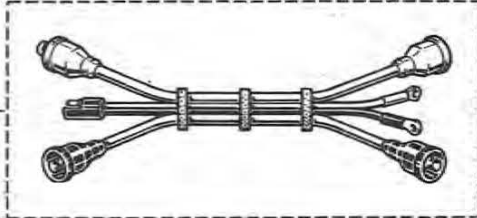

79 10 013 828

79 10 245 594

79 10 245 593



BN9Y

79 10 245 703

77 00 569 597

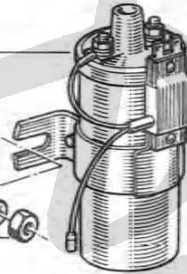

79 03 056 027

79 03 032 009



77 01 017 795

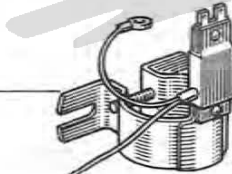

77 00 550 238

77 00 544 686

77 00 572 236

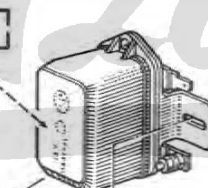
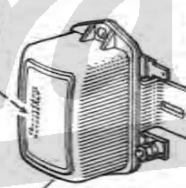
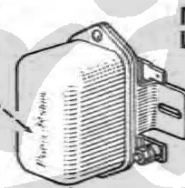

08 54 834 200

79 03 056 036

77 03 016 022



79 10 245 551

79 46 000 030

79 03 062 001

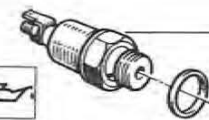

19.01

A P.R.1030



19.01

A P.R.1030

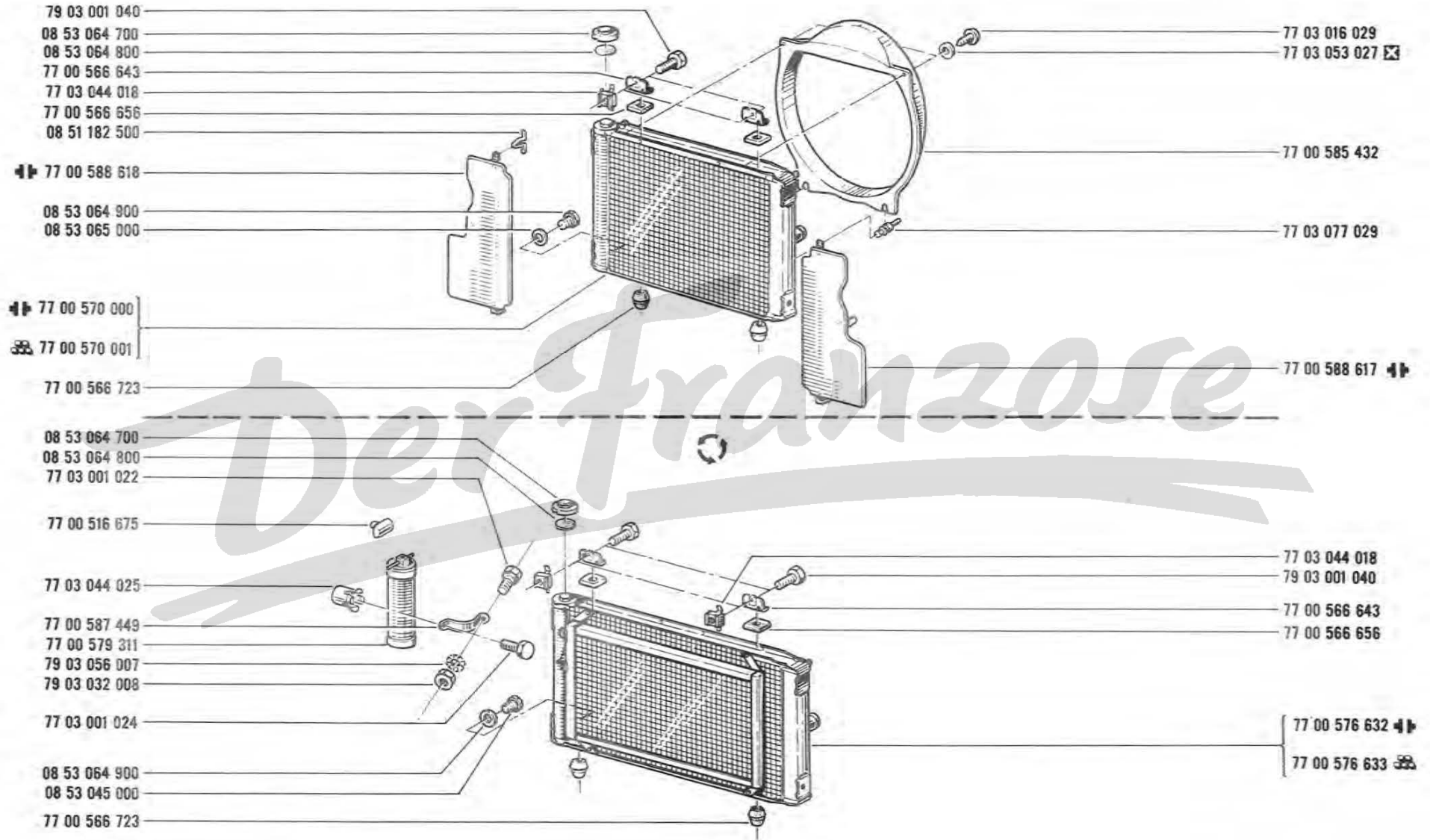
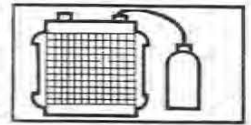

Derfranzose

19.10
A P.R.1030

19.10
A P.R.1030

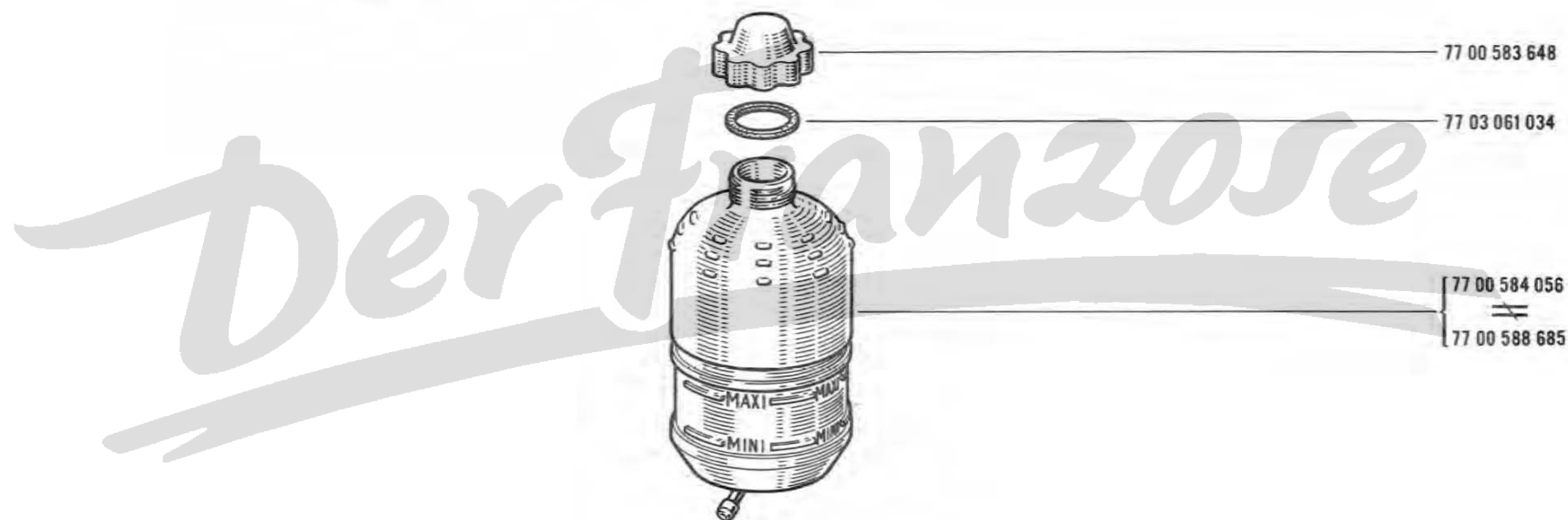
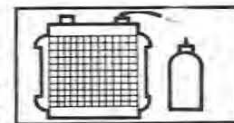

77 00 583 648

77 03 061 034

77 00 584 056

77 00 588 685

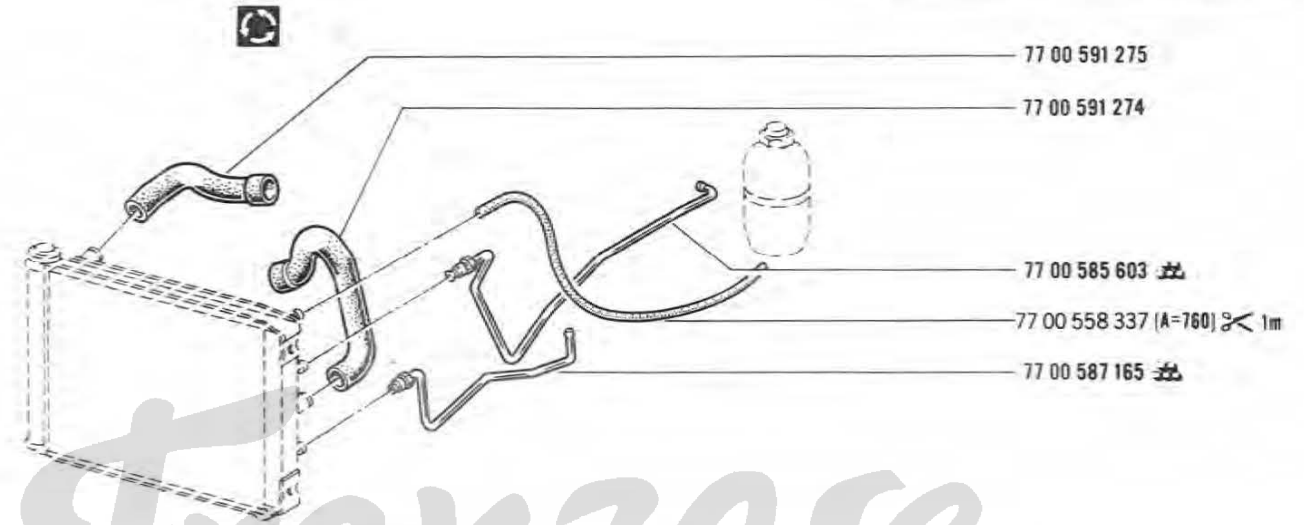
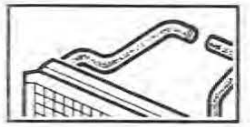

Der Franzose

77 00 591 272

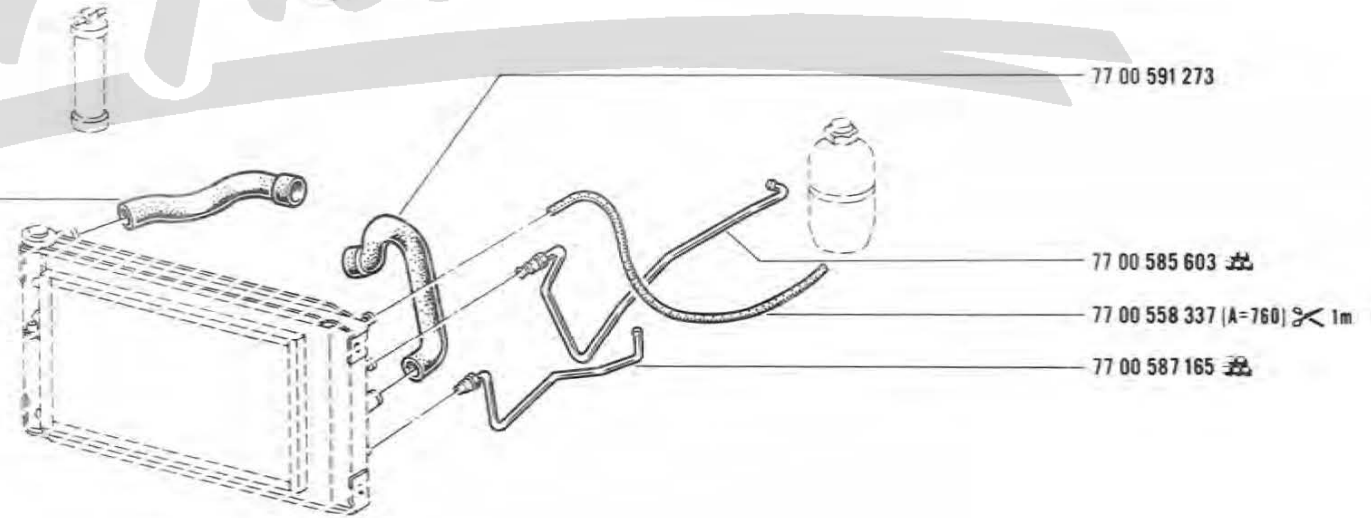

19.30

A P.R.1030

19.30

A P.R.1030

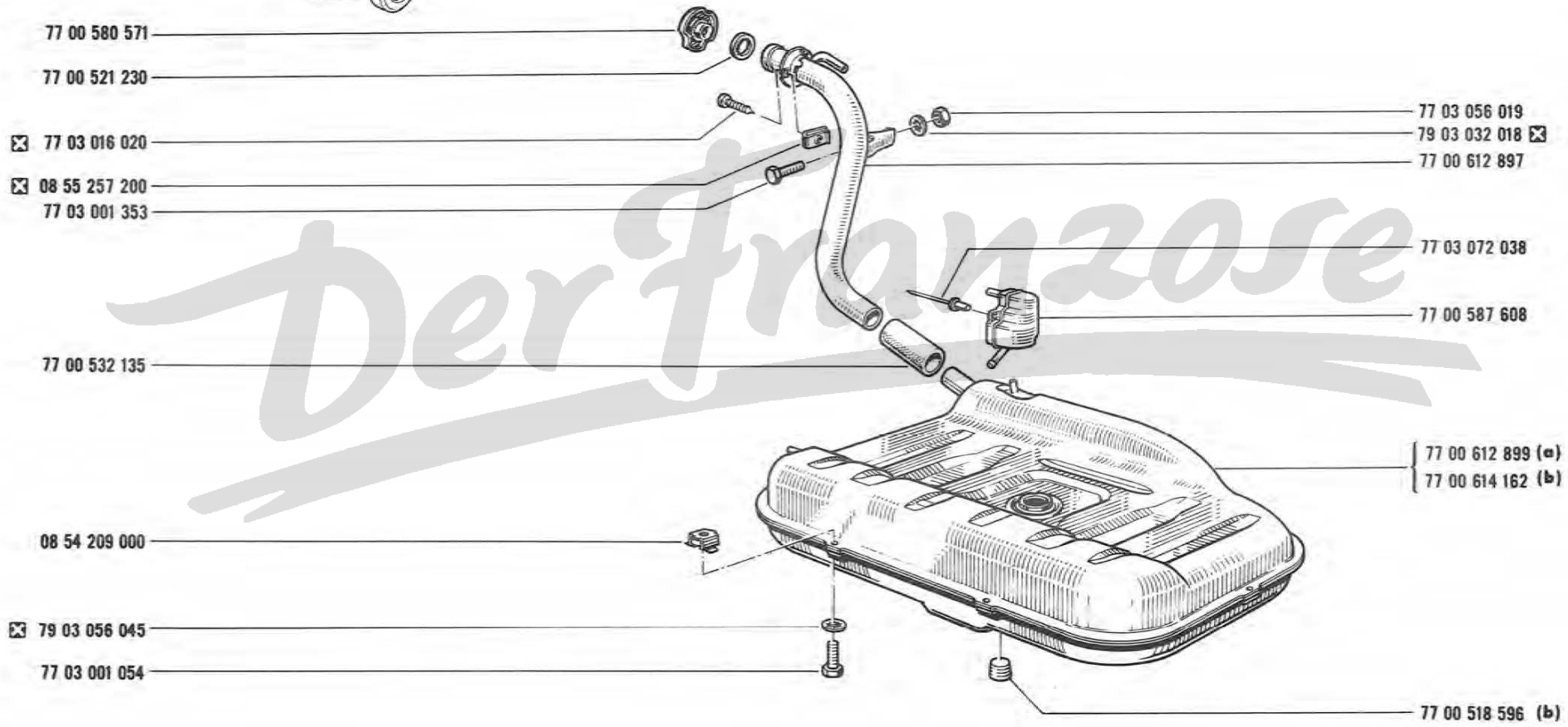

(a) R 1273 /100/600

(b) R 1273 /120

19.40

A P.R. 1030

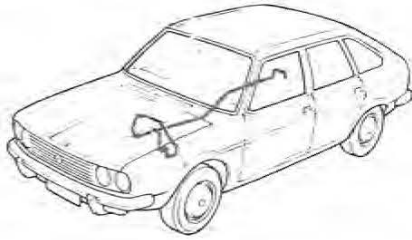

19.40

A P.R. 1030

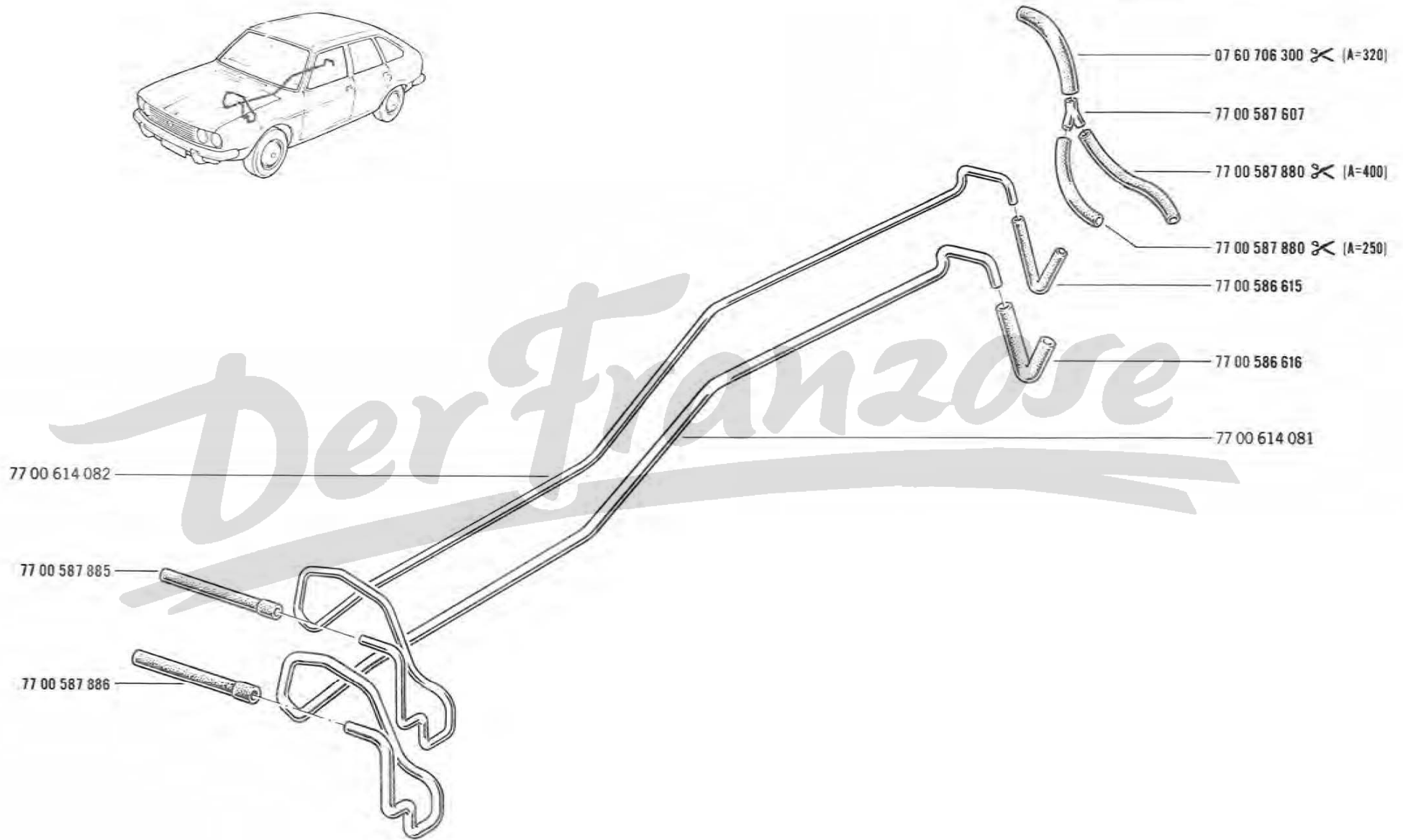
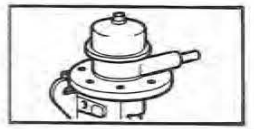

19.50

A P.R.1030



19.50

A P.R.1030

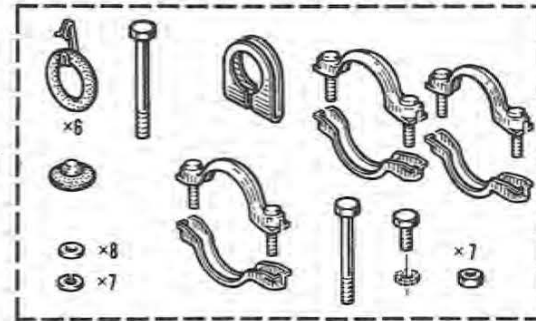
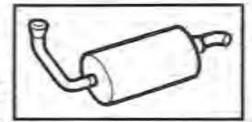

77 01 458 269

77 03 046 031
79 03 053 157
77 00 584 323
77 03 016 144

77 00 584 120
77 00 570 615

77 00 578 954

☒ 79 03 053 043

06 08 517 007

77 00 578 951

77 03 001 174

☒ 79 03 053 043

☒ 79 03 053 043

☒ 77 03 055 011

☒ 79 03 032 018

77 03 072 050
77 03 001 054

77 00 580 029

77 03 072 050
77 00 611 470
77 00 570 615

77 00 570 615

77 00 579 787

77 00 611 471

79 03 053 043 ☒

77 03 055 011 ☒

79 03 032 018 ☒

79 03 053 043 ☒

79 03 056 014 ☒

79 03 032 018 ☒

77 00 512 226

19.60

A P.R. 1030



19.60

A P.R. 1030

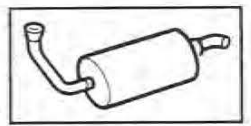

77 00 570 615
77 00 571 785

77 00 611 324

77 00 569 127

77 00 611 324

77 00 611 325
☒ 79 03 053 043
☒ 79 03 055 011
☒ 79 03 032 018

77 00 579 098

77 03 072 050

77 00 570 615

77 00 570 615

77 00 579 308

79 03 032 018 ☒
79 03 055 011 ☒
79 03 053 043 ☒
77 00 611 325

Der Franzose

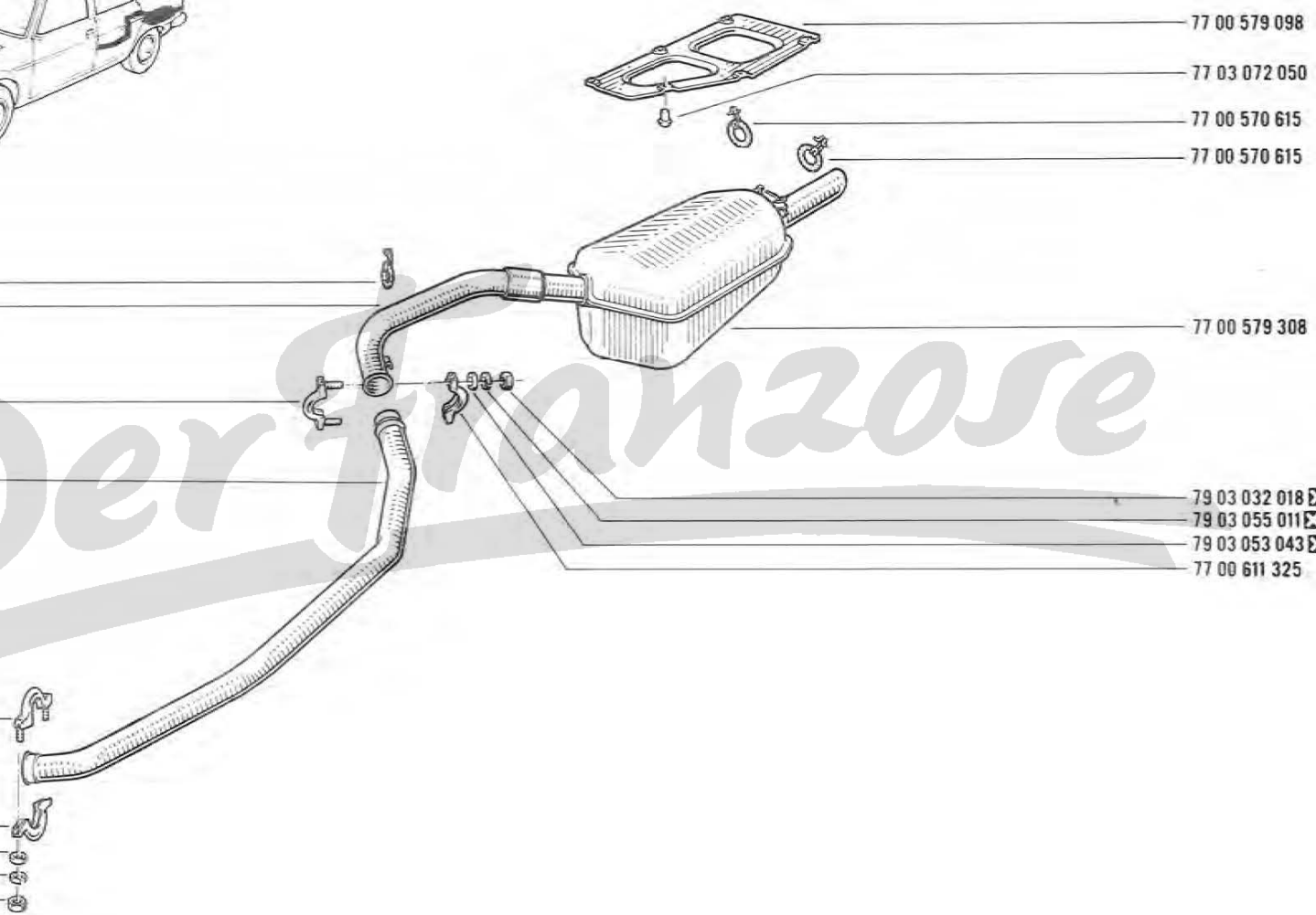

19.80

A P.R.1030

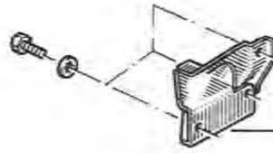

19.80

A P.R.1030

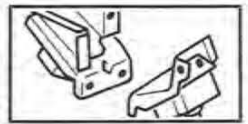

77 00 581 189

77 00 578 526

77 03 001 052

77 00 572 966

77 00 578 525

77 03 001 174

79 03 056 030

79 03 032 018

77 00 582 534

77 03 001 052

79 03 056 045

77 00 567 020

77 03 001 187

77 00 582 535

79 03 056 045

77 03 001 054

77 03 034 012

77 03 053 066

79 03 056 047

77 03 001 077

77 00 581 192

79 03 056 045

77 03 001 054

77 00 580 990

77 00 565 940

79 03 053 050

77 03 034 047

77 03 034 012

77 00 563 385

77 00 563 409

77 00 563 410

77 03 001 052

79 03 056 045

79 03 032 018

77 03 034 046

Derfranzose

20.01

A PR.1030

20.01

A PR.1030

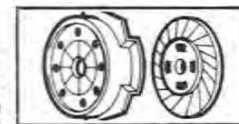

77 00 575 529

77 03 055 010

77 03 009 069

77 00 588 689

77 01 200 431

08 53 958 300

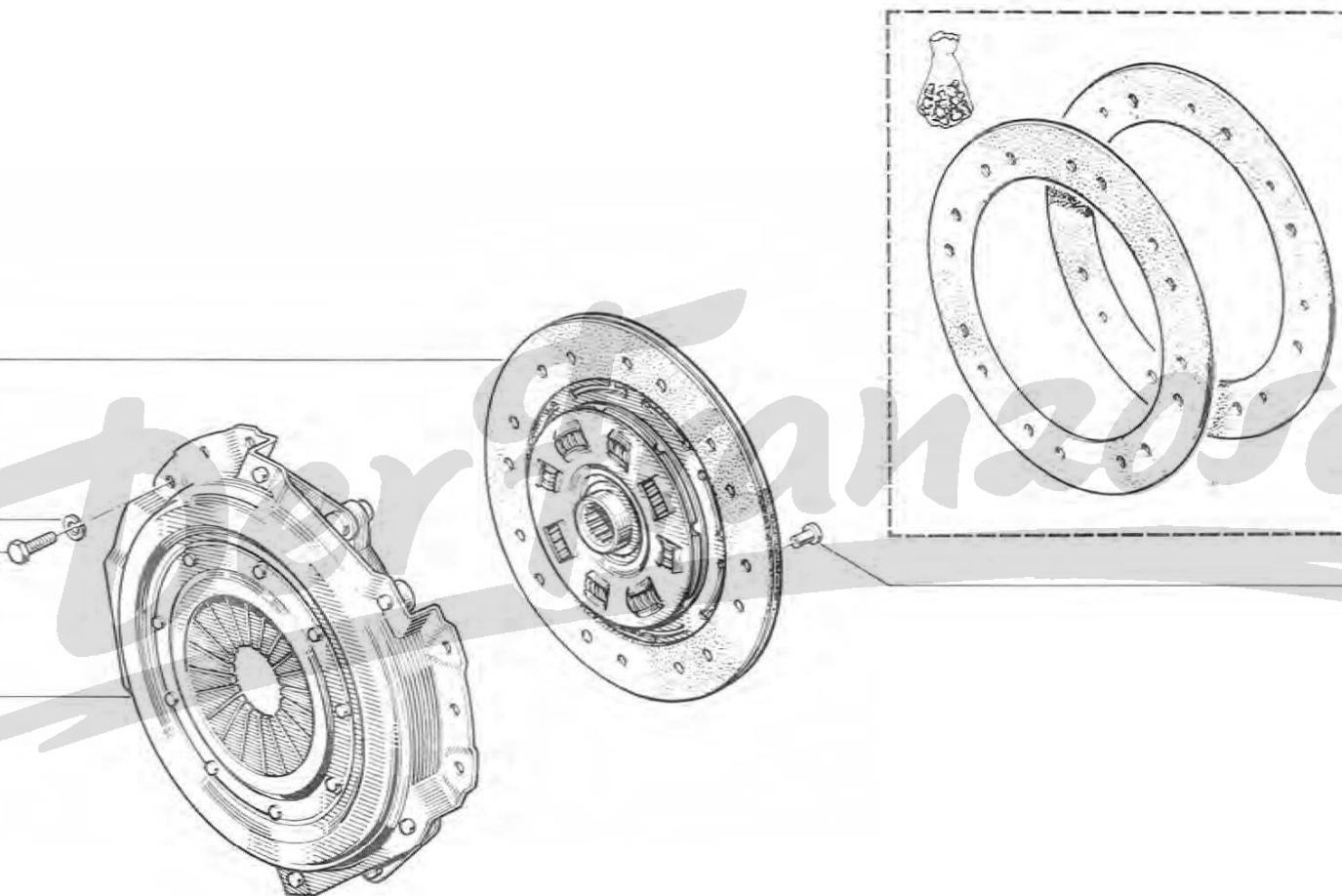

21.01

A P.R.1030



21.01

A P.R.1030

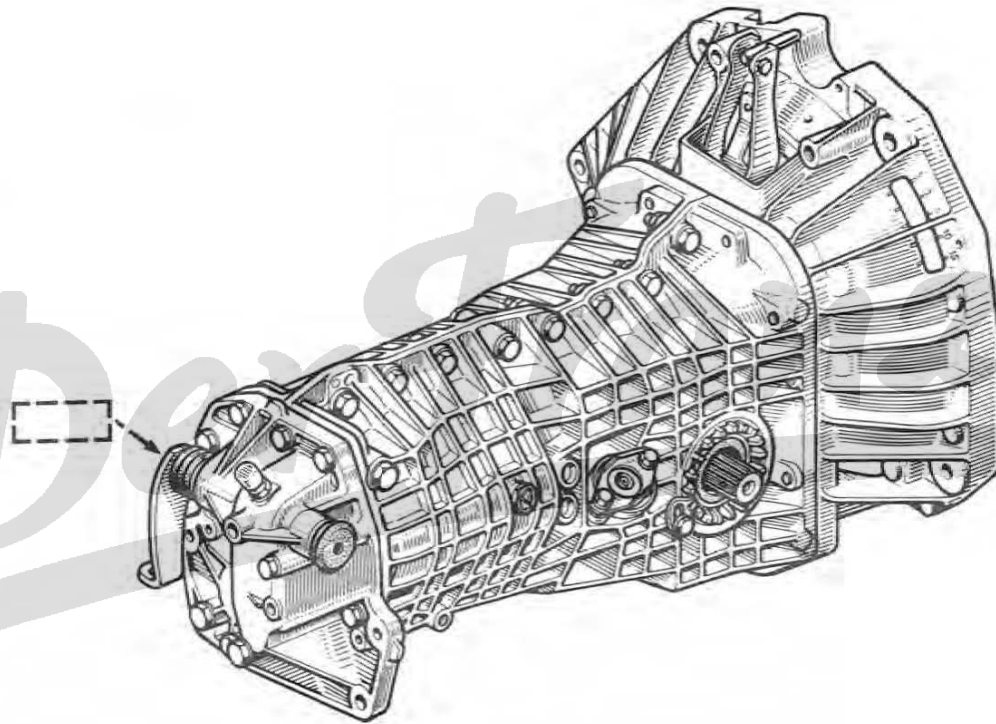
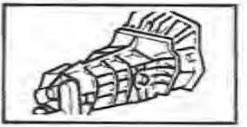

367-00

77 01 518 800

21.20

A P.R. 1030



21.20

A P.R. 1030

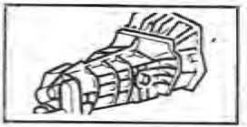

07 02 980 300

77 03 067 039

07 05 866 700

77 00 552 952

08 24 490 900

77 03 087 055

77 00 590 370

77 00 557 321

77 03 067 039

08 54 761 902

77 03 001 646

77 03 058 008

08 54 761 902

77 03 001 363

08 54 761 902

77 03 001 431

77 03 001 584

08 54 761 902

77 03 001 643

77 03 001 648

77 03 058 008

77 03 001 138

77 03 058 006

77 00 560 057

77 01 458 259

77 00 564 533

07 02 980 300

77 00 563 836

77 03 056 006

77 03 001 647

77 03 032 013

08 52 888 102

77 03 001 649

77 03 032 013

06 08 420 300

08 52 888 102

77 03 001 645

77 03 001 644

08 52 888 102

77 03 032 013

77 03 032 035

08 54 761 902

77 03 001 646

77 03 001 645

06 08 420 300

08 52 888 102

77 03 032 013

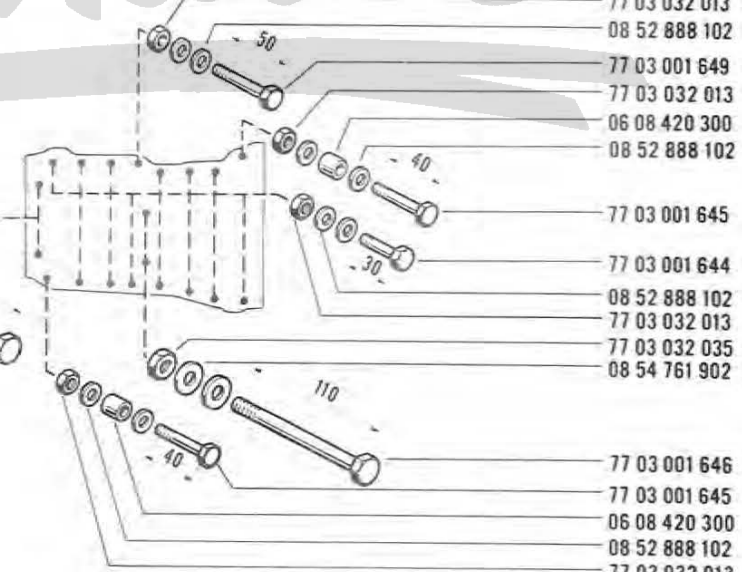
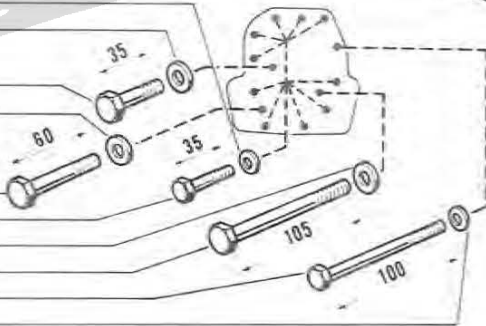

21.30

A P.R.1030



21.30

A P.R.1030

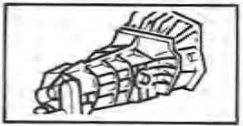

77 00 587 953

06 08 420 300

77 00 557 845

77 01 458 330

77 03 001 038

79 03 056 012 ☒

77 00 581 524

77 00 565 780

77 03 001 038

79 03 056 012 ☒

77 00 565 779

77 03 058 034

77 03 001 362

77 03 001 244

77 00 541 465

77 03 001 362

77 03 058 034

77 03 058 007

77 03 001 362

77 03 058 034

77 00 541 465

77 03 058 034

77 03 001 431

77 03 001 362

77 03 058 034

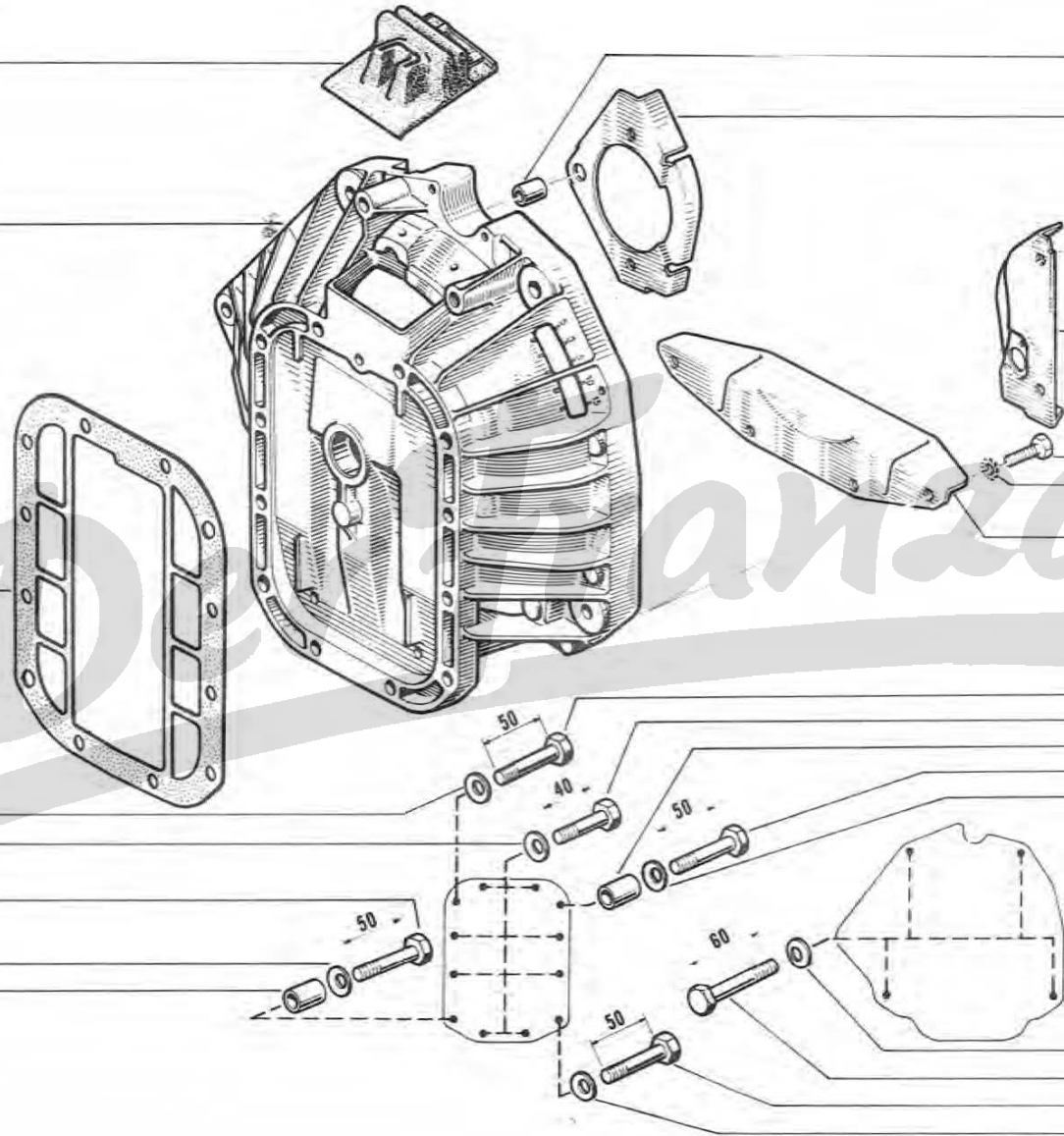

21.40

A PR.1030



21.40

A PR.1030

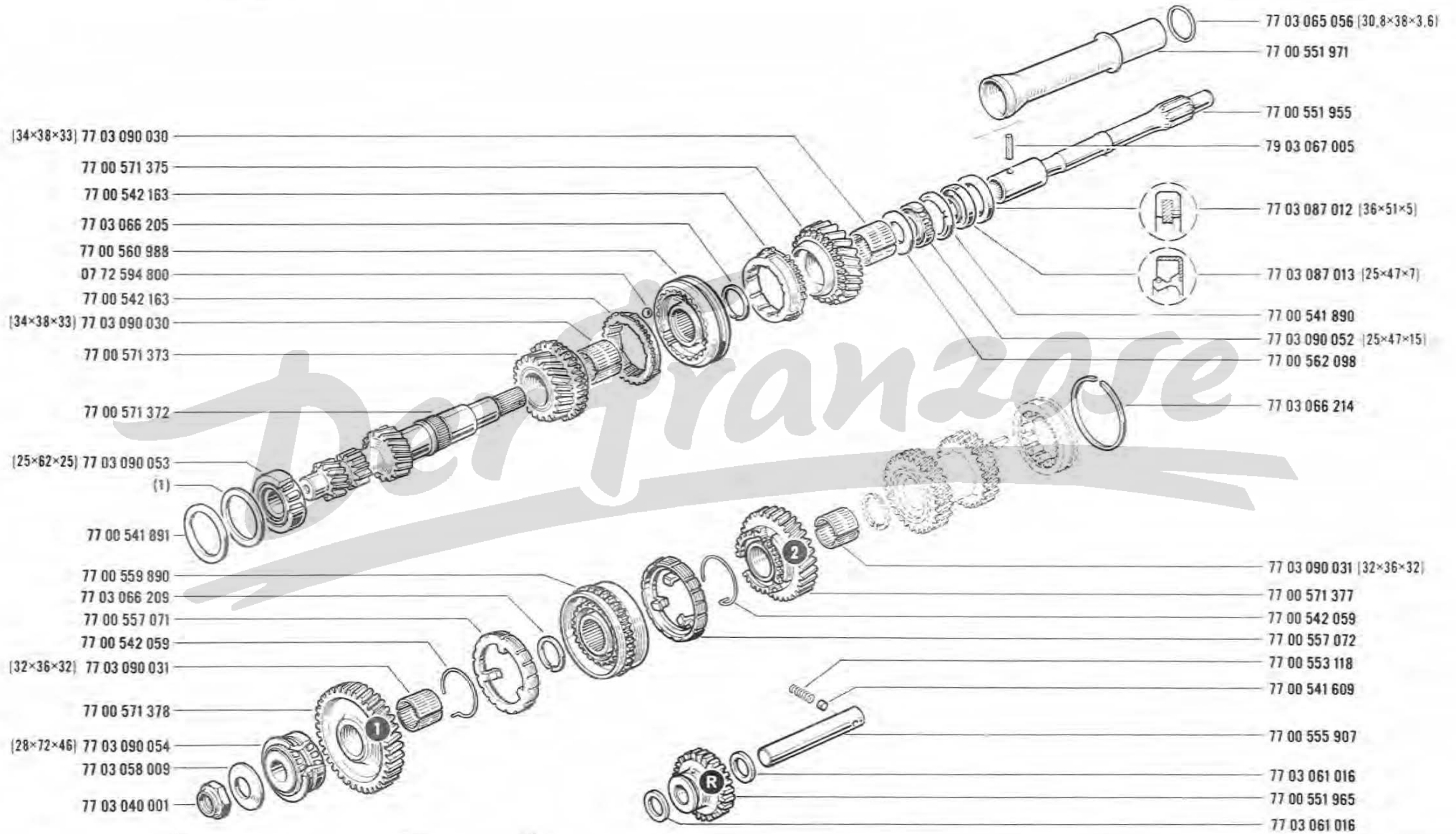
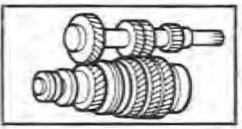

(1) 			
77 03 053 143	A=0,10	77 03 053 120	A=0,75
77 03 053 144	A=0,20	77 03 053 121	A=1
77 03 053 118	A=0,25	77 03 053 122	A=2
77 03 053 119	A=0,50		

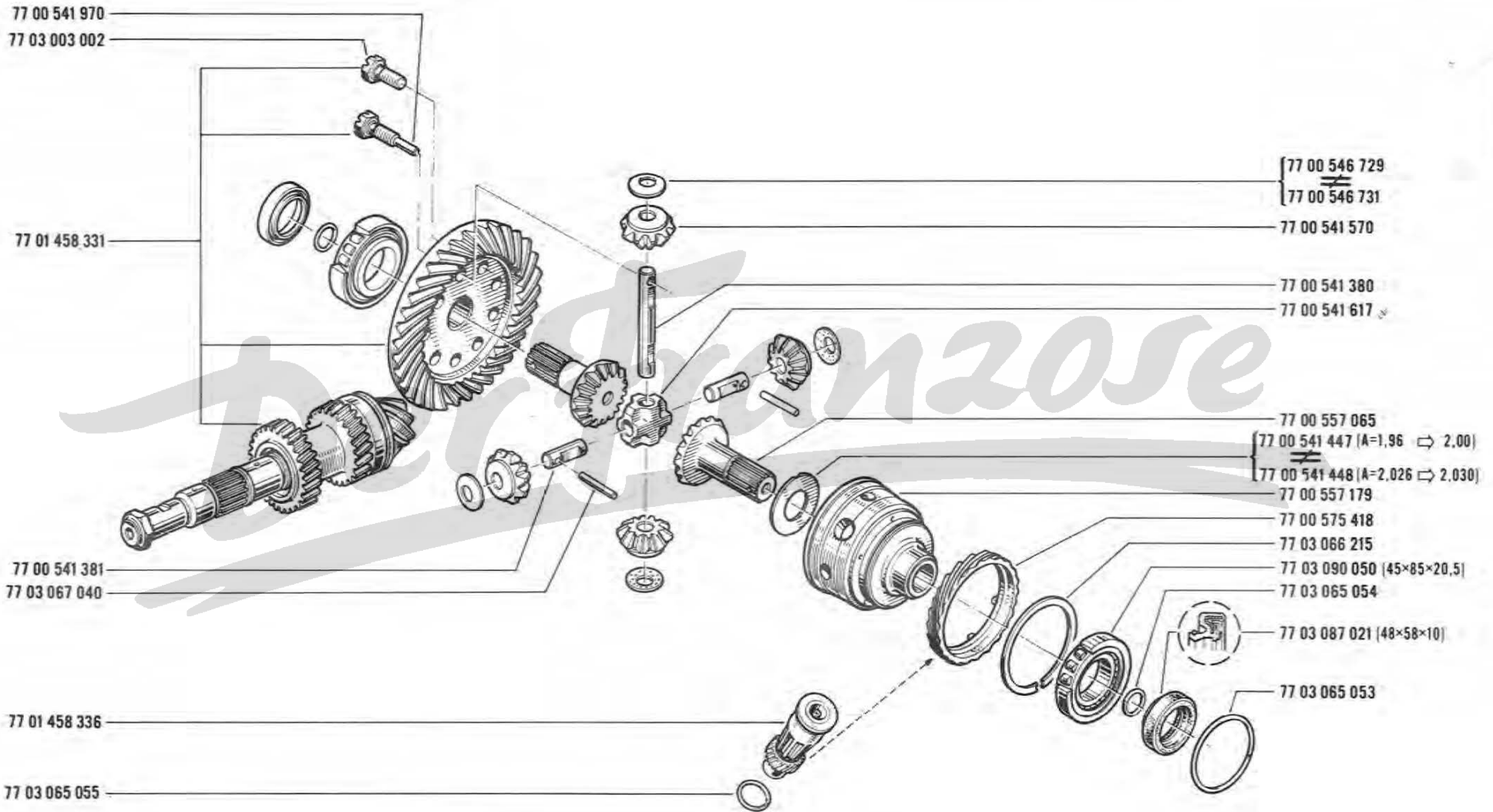
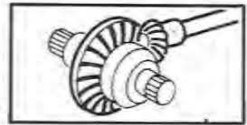

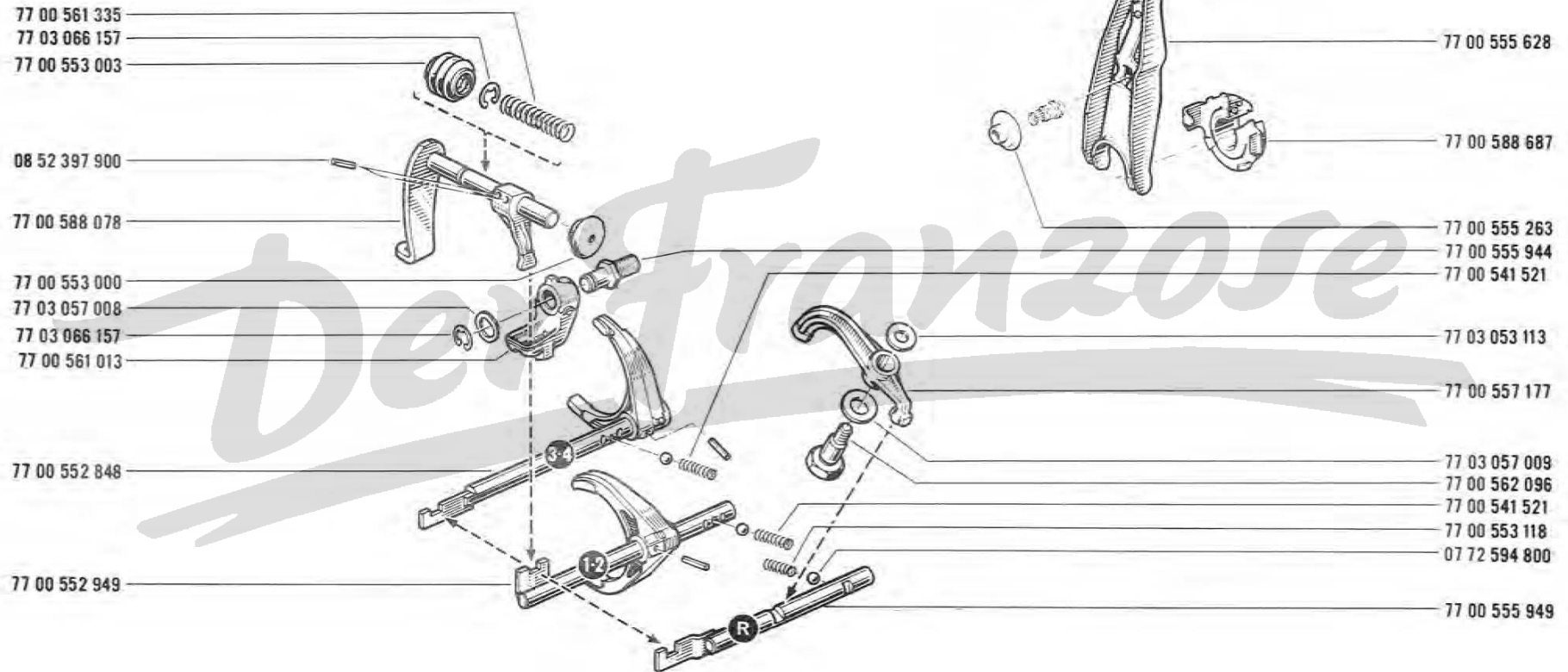
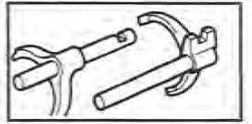

23.01
A P.R.1030



23.01
A P.R.1030

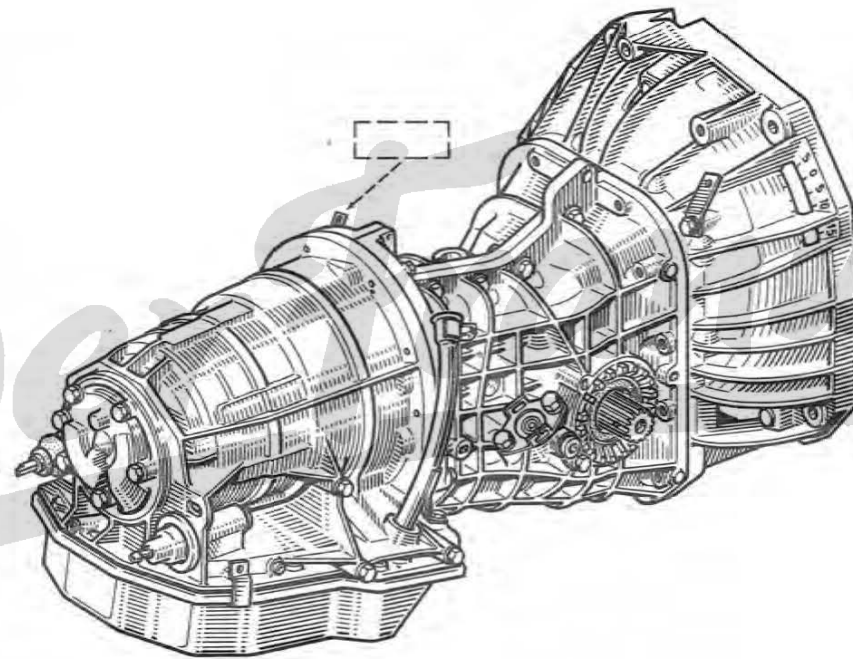

4141-00

77 01 458 450
77 01 498 526 7/8

23.20

A P.R.1030



23.20

A P.R.1030

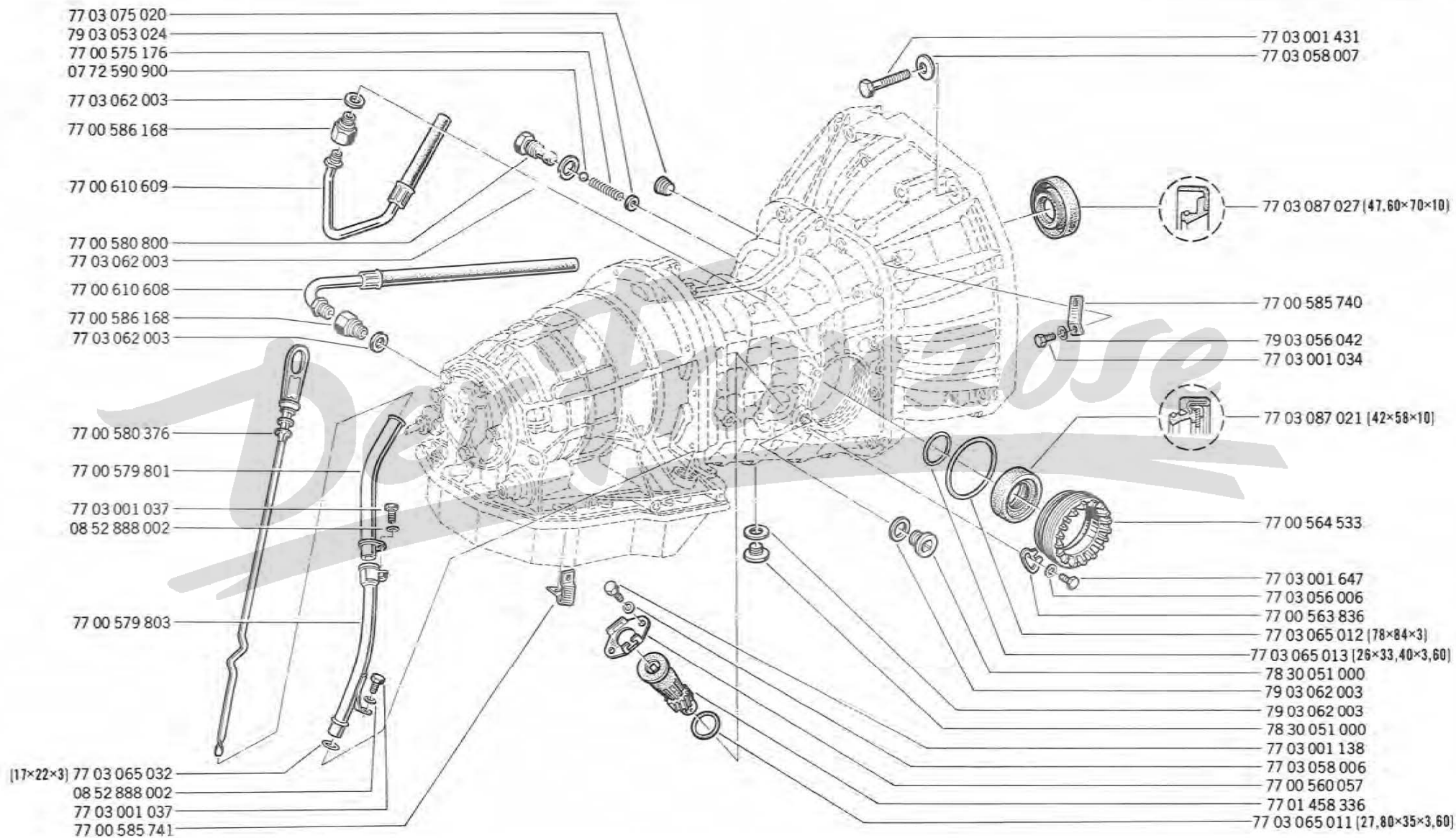

23.30

A P.R.1030



23.30

A P.R.1030

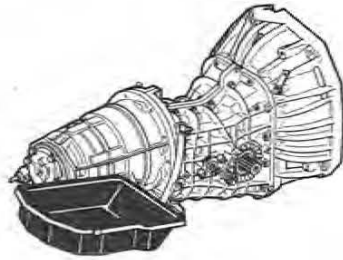
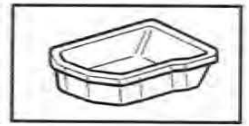

77 00 570 091

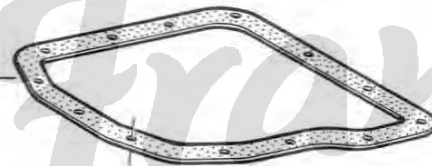

Der Franzose

77 00 585 346

08 52 888 002

77 03 001 037

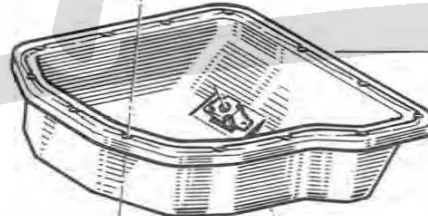

79 03 062 003

79 03 075 033



23.40

A P.R.1030



23.40

A P.R.1030

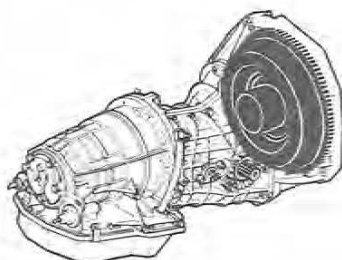

77 00 556 438

77 00 581 572

77 00 588 684

77 03 057 002

77 03 001 180

77 00 556 438

77 00 589 290

Dexia Case

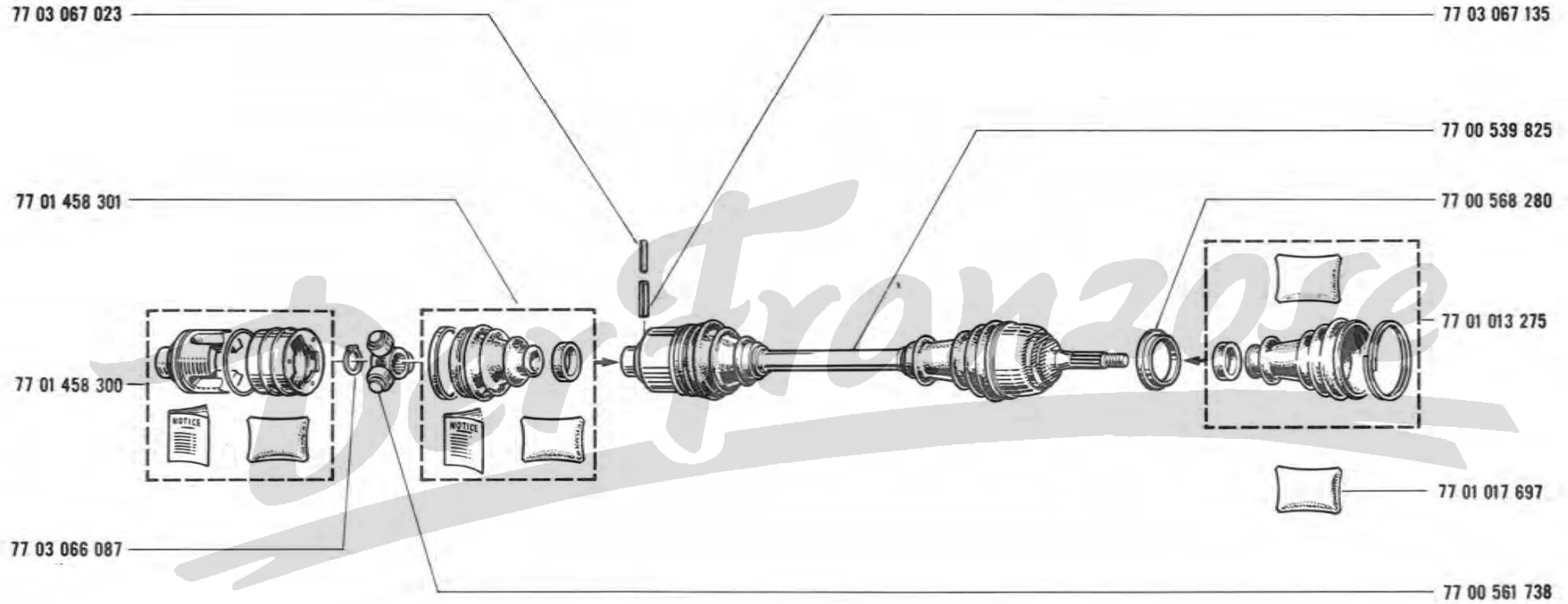
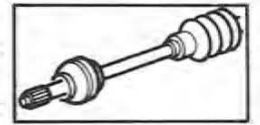

31.01

A P.R.1030

31.01

A P.R.1030

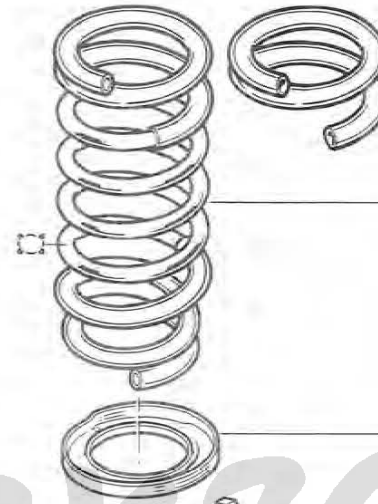
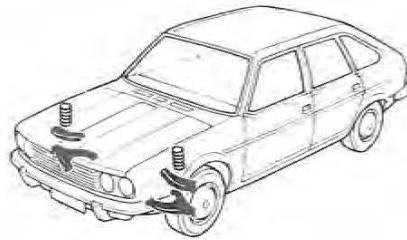
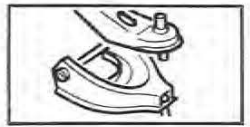

77 00 574 207

- 77 01 458 263 (a)
- 77 01 458 264 (b)
- 77 01 458 298 (c)
- 77 01 458 299 (d)

- (14x32x58x43) 77 00 572 178
- 77 03 053 015
- 77 03 034 021



77 00 567 581

77 03 034 061

77 00 569 495

77 03 001 187

77 03 034 061

79 03 053 114

77 00 572 179

77 00 568 568

77 00 568 622

77 00 568 205

79 03 053 050

☒ 77 03 034 012

77 00 581 990

77 00 568 268

77 00 569 340

77 00 561 763

77 00 568 624

77 03 034 062

79 03 053 061

77 00 567 908

77 00 583 357

77 00 572 180

77 00 567 580

(a) R 1273

(b) R 1273

(c) R 1273

(d) R 1273

31.30

A PR.1030



77 01 458 261

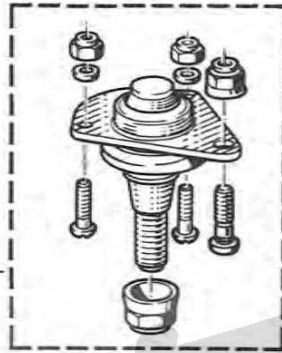

77 01 458 260

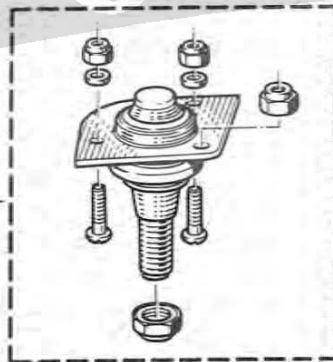

31.30

A PR.1030

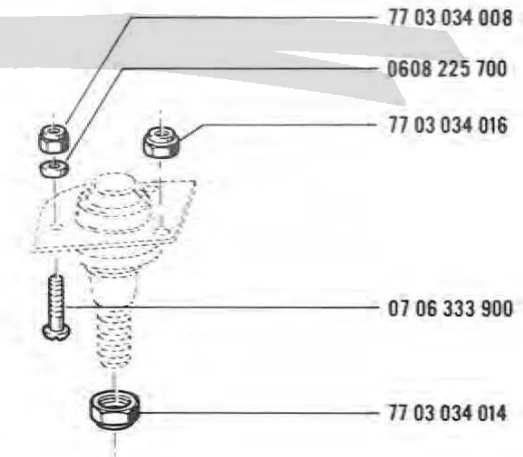
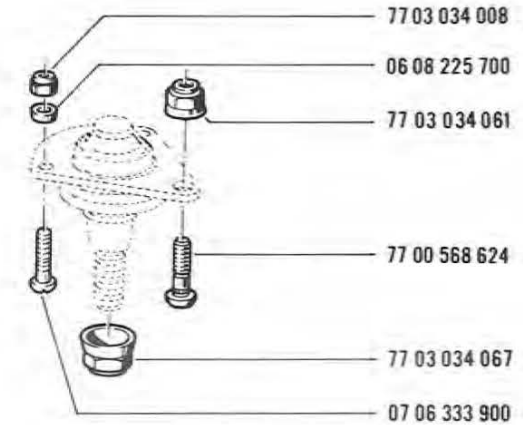

Der Franzose

31.40

A PR 1030

31.40

A PR 1030

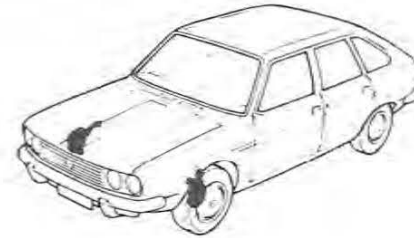

77 00 568 954

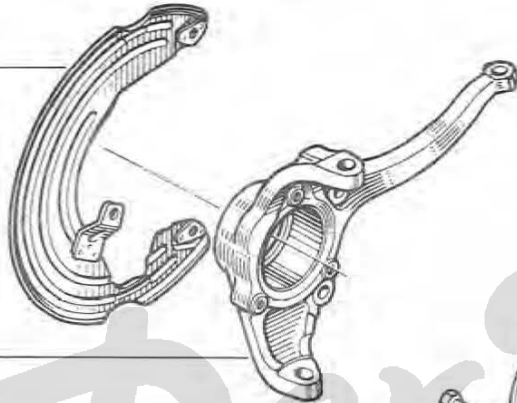

77 00 567 465

77 03 001 399

79 03 056 014

77 00 568 951

77 00 567 662

(42x84x39) 77 03 090 059

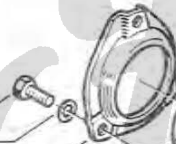

77 00 567 464

77 03 001 018

79 03 056 039

77 00 568 952

77 00 574 309

77 00 561 367

05 54 732 800

77 00 561 274

77 03 055 012

77 03 001 185

50 03 034 014

77 03 053 134

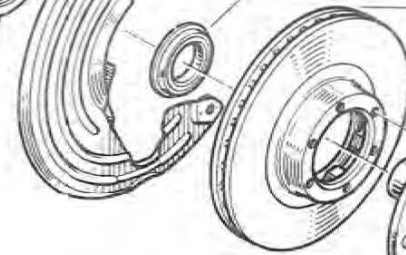

32.01
A PR.1030

32.01
A PR.1030

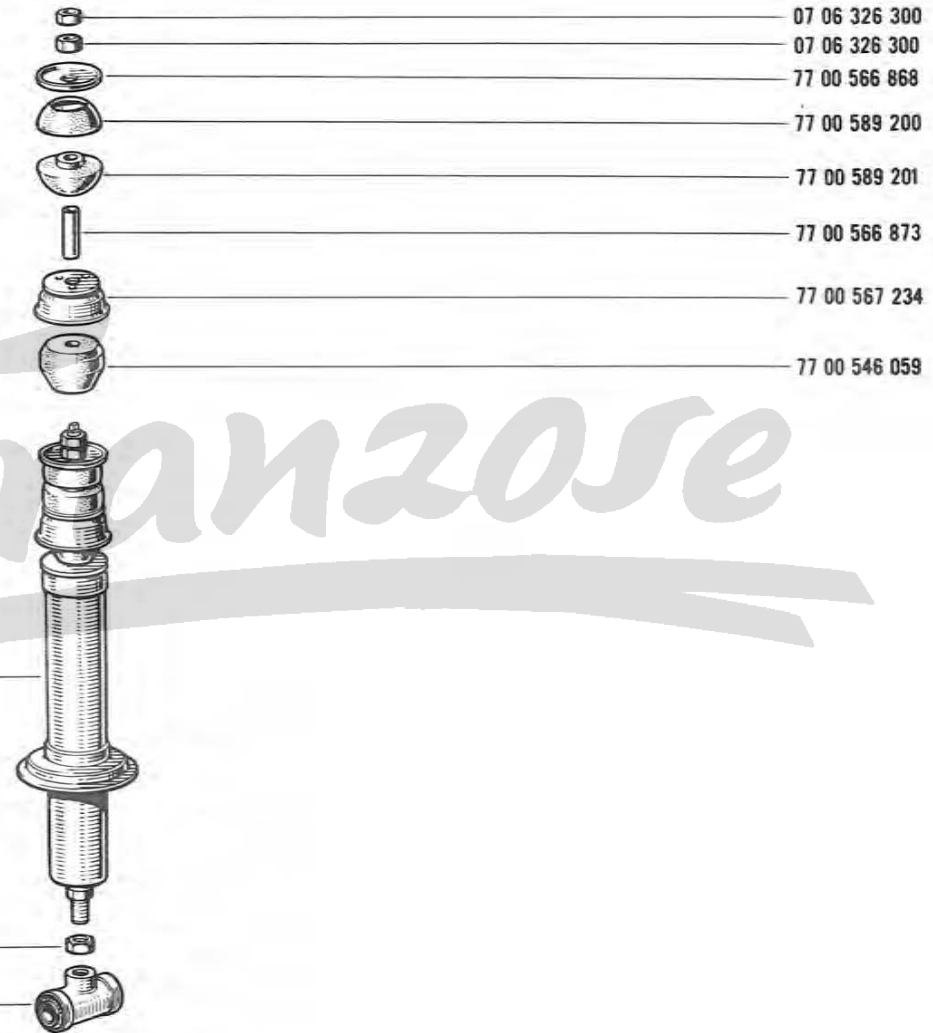
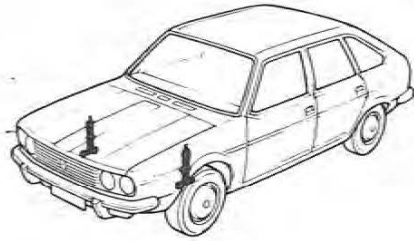
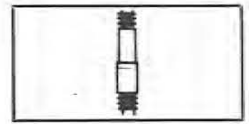

Der Franzose

32.10
A P.R.1030

32.10
A P.R.1030

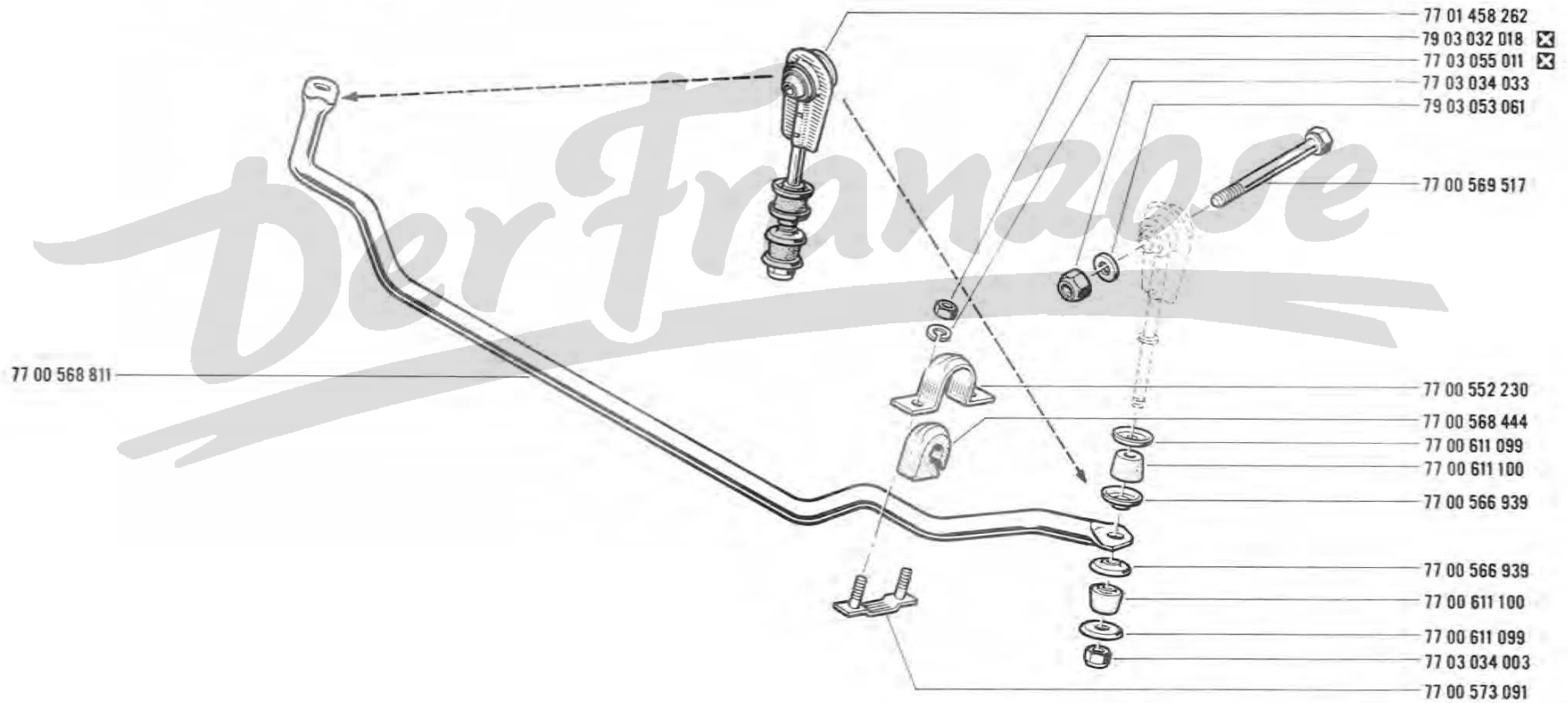
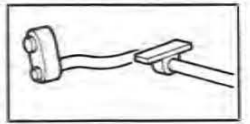

32.30

A P.R.1030

32.30

A P.R.1030

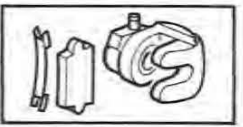

77 01 018 786

77 01 200 577

77 03 062 001

06 03 936 600

08 54 119 700

77 01 200 578

77 01 017 791

77 01 001 447

77 01 017 790

77 01 018 784

77 01 018 785

77 03 055 002

50 03 001 104

77 03 055 002

77 00 568 956

77 01 200 579

77 01 200 599

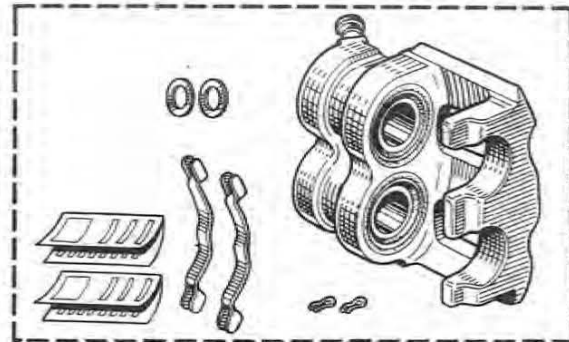
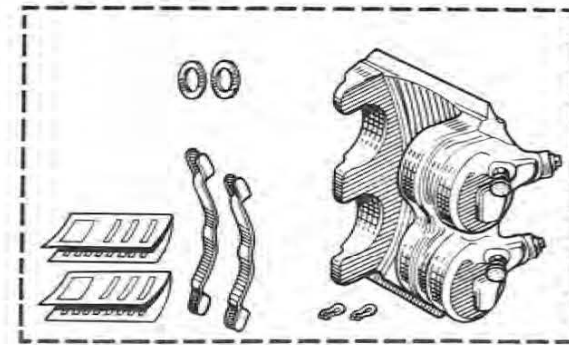
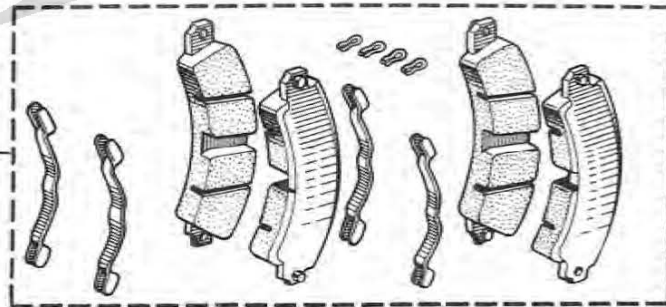
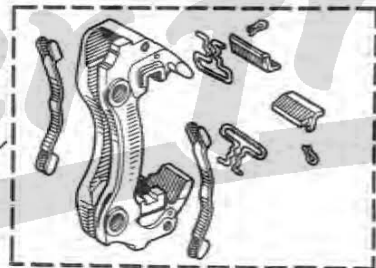
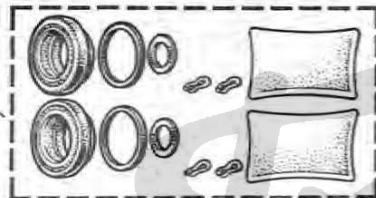
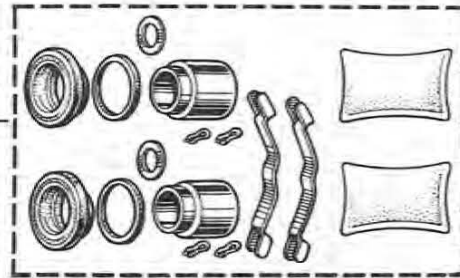

77 01 200 576

77 01 200 575

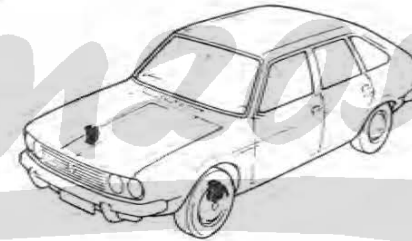

33.01

A PR 1030

33.01

A PR 1030

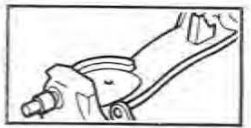

77 03 001 637

77 00 568 543

77 00 569 444

77 00 572 184

77 00 572 184

77 03 053 136

77 00 572 323

77 03 053 136

77 03 034 013

77 03 034 047

79 03 053 050

77 03 001 192

77 00 572 185

77 00 568 456

79 03 053 050

77 03 034 047

[77 01 458 266] (a)
[77 01 458 302] (b)

77 00 574 206

77 00 569 442

77 00 568 446

77 00 569 601

77 00 568 440

77 00 572 182

77 00 568 495

77 00 568 541

77 03 001 661

77 03 053 071

77 03 053 071

77 03 034 013

77 00 572 183

77 00 573 228

77 03 034 015

77 03 001 192

79 03 053 050

(a) R 1273

R 1273

(b) R 1273



Der Frontzone

33.40

A P.R.1030

33.40

A P.R.1030

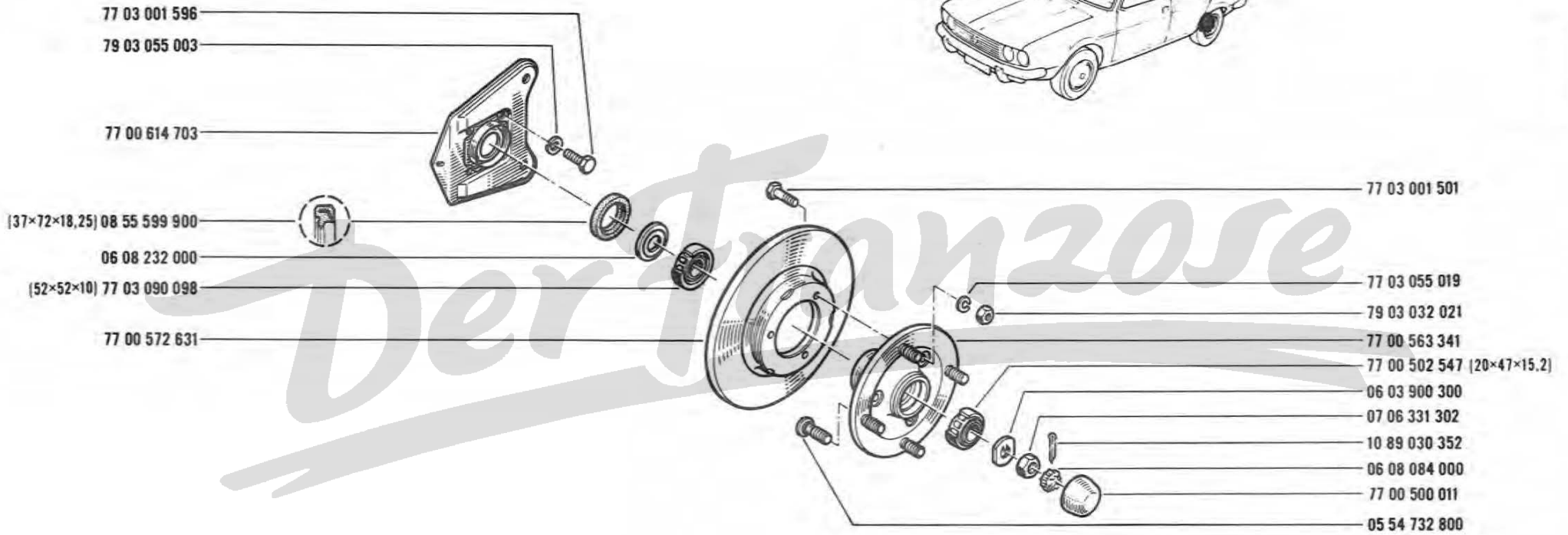
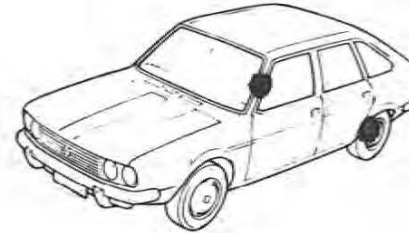

34.01

A P.R.1030

34.01

A P.R.1030



79 10 017 459

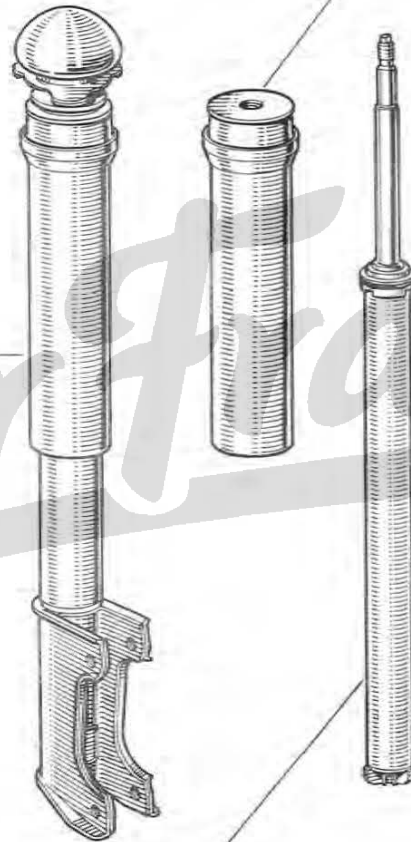

77 01 200 520



77 00 571 562



77 00 613 052



77 03 034 013

79 10 017 476



77 00 568 556



77 00 568 554



77 00 568 556



77 00 568 554



77 00 575 493



78 53 127 000



79 10 017 469



79 10 016 365



79 03 065 007



79 10 004 173



77 01 200 519

Der Franzose

34.10

A P.R.1030

34.10

A P.R.1030

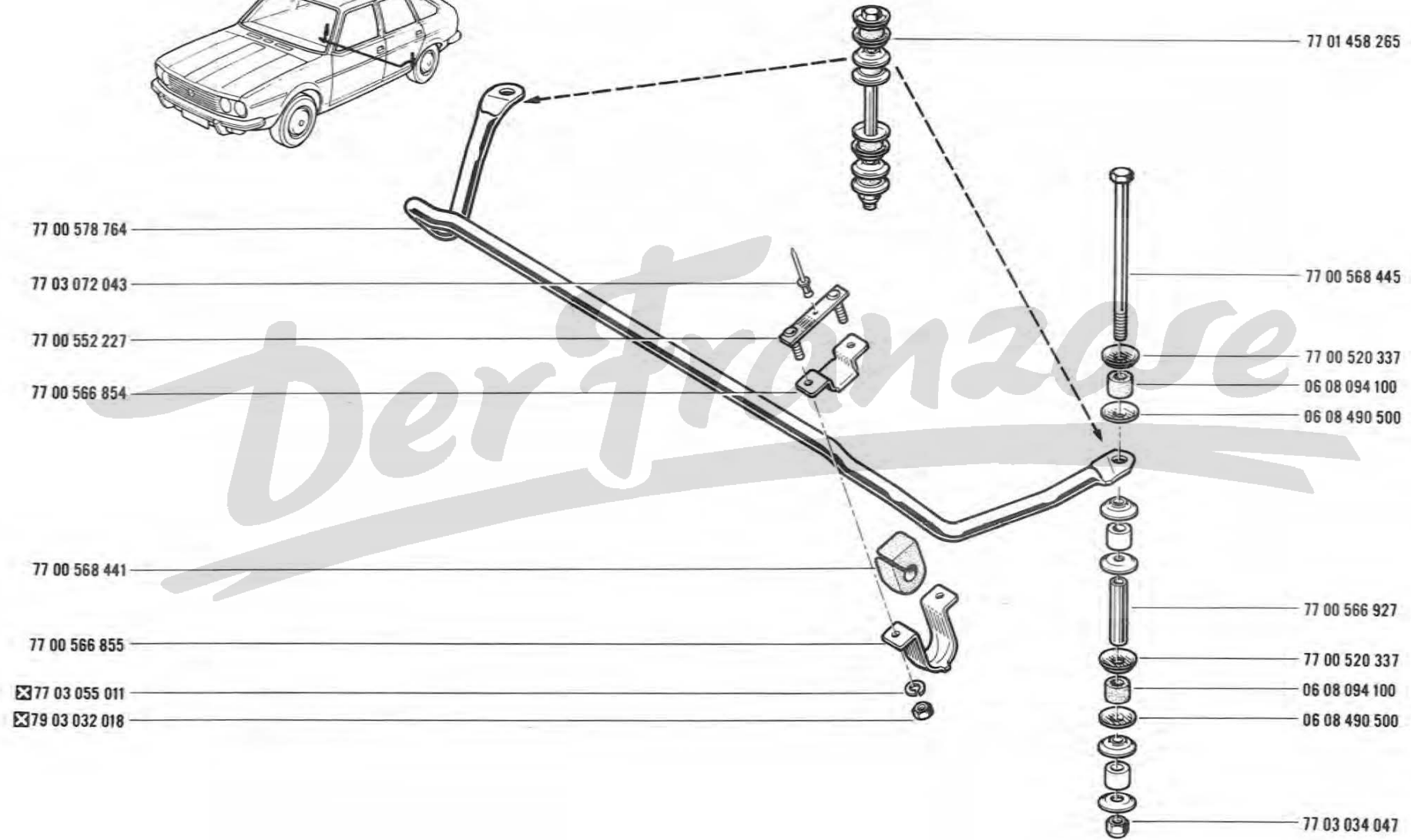
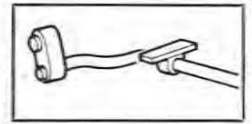

34.30

A P.R.1030

77 01 200 592

77 01 200 592

77 01 010 287

77 01 009 302

77 01 009 301

77 03 062 001

77 03 936 600

08 54 119 700

77 01 001 447

77 01 018 850

77 01 010 578

77 01 001 445

77 03 055 002

77 03 001 497

77 01 018 849

77 01 200 591

77 01 200 59E

77 01 017 100

77 01 200 594

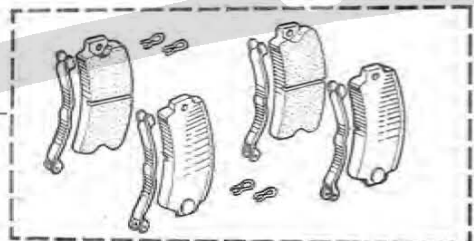
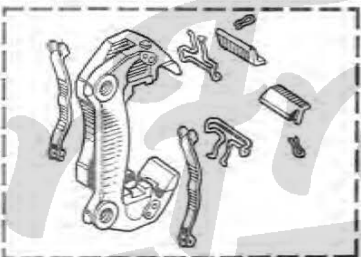
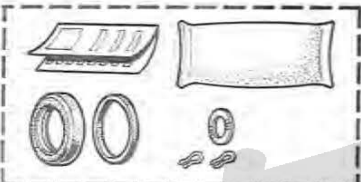
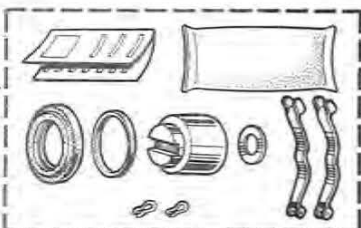

34.30

A P.R.1030

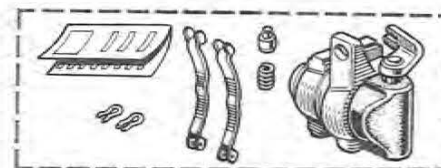
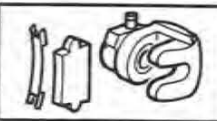

77 01 200 595

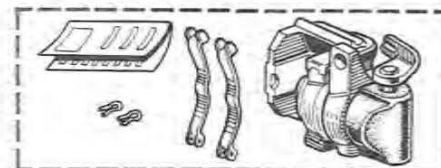

77 01 200 590

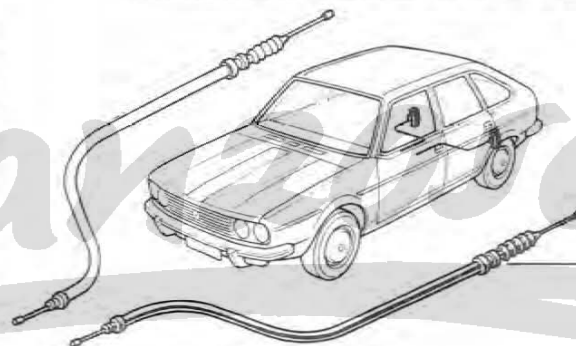

77 00 578 621

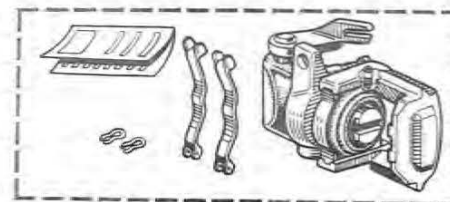

77 01 200 589

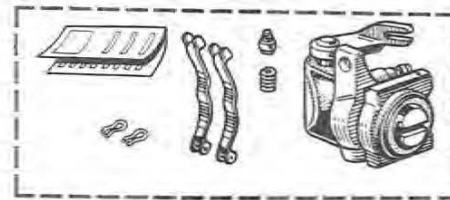

77 01 200 588

35.01

A P.R.1030

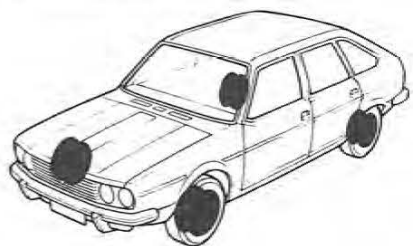

35.01

A P.R.1030



77 00 575 503

Derivazione

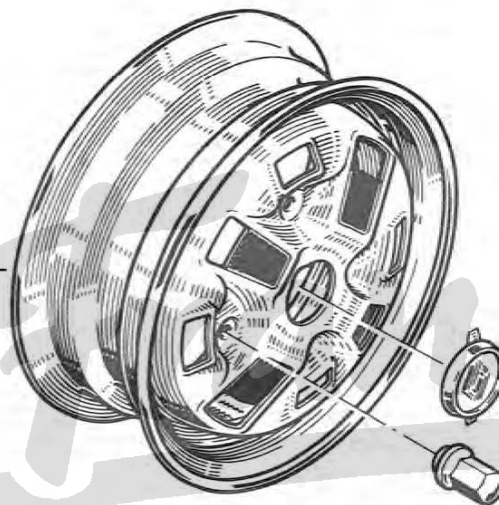

77 00 611 052

77 00 532 727

35.10

A PR 1030

35.10

A PR 1030

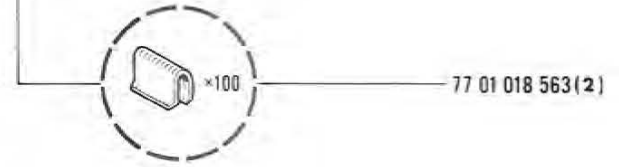
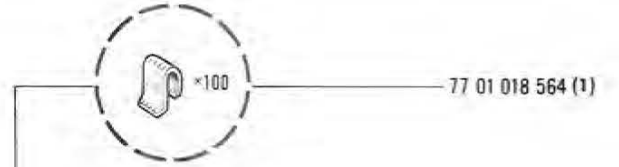
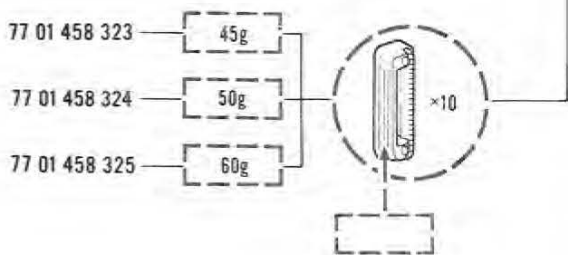
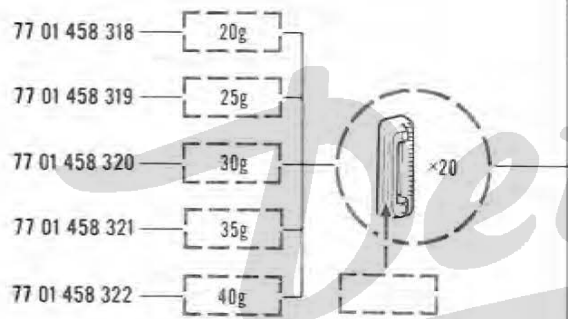
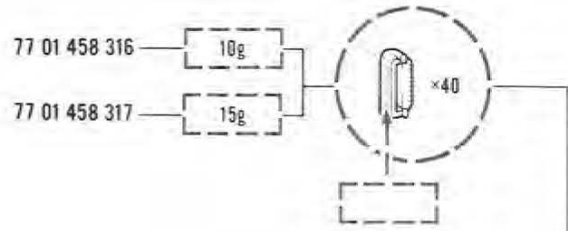

(1)	☑		10g
(2)	☑		15g → 60g

36.01

A P.R.1030



36.01

A P.R.1030

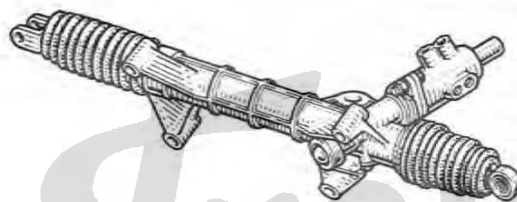
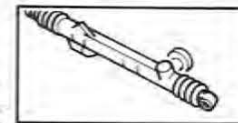

[77 01 458 312 4P]
[77 01 458 314 2P]

Der Franzose

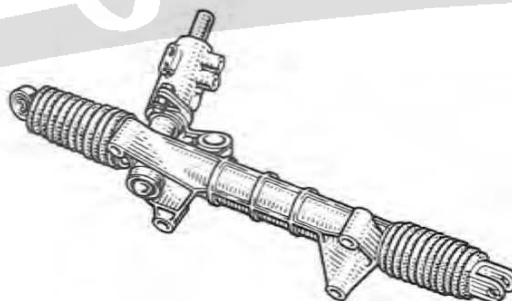

[77 01 458 313 4P]
[77 01 458 315 2P]

36.20

A PR.1030

36.20

A PR.1030

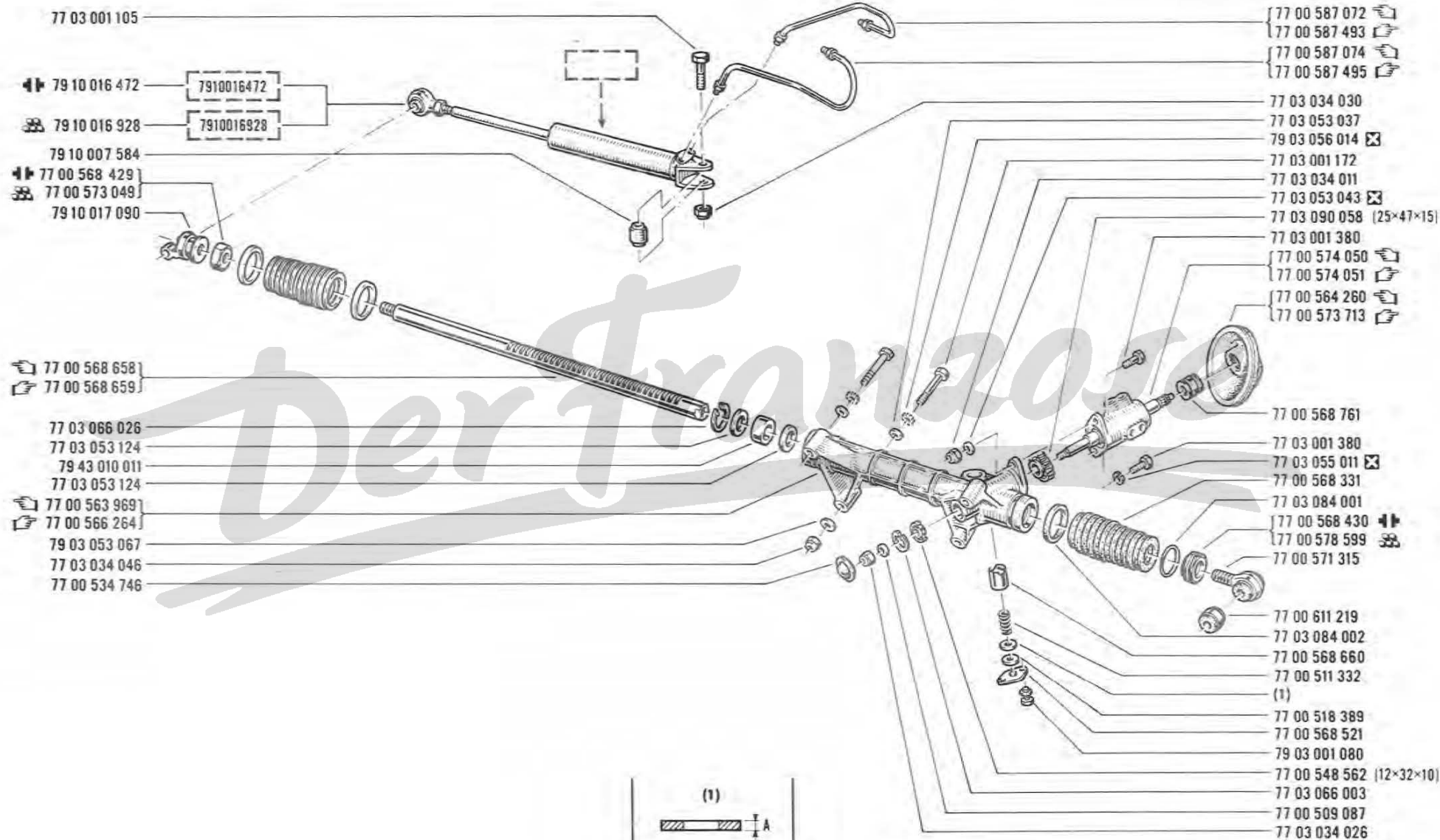
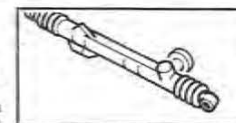

(1)

77 00 509 236	A=0,10
77 00 518 387	A=0,15
77 00 509 237	A=0,20
77 00 509 238	A=0,30
77 00 509 239	A=0,40
77 00 509 240	A=0,50

36.30

A P.R.1030



36.30

A P.R.1030

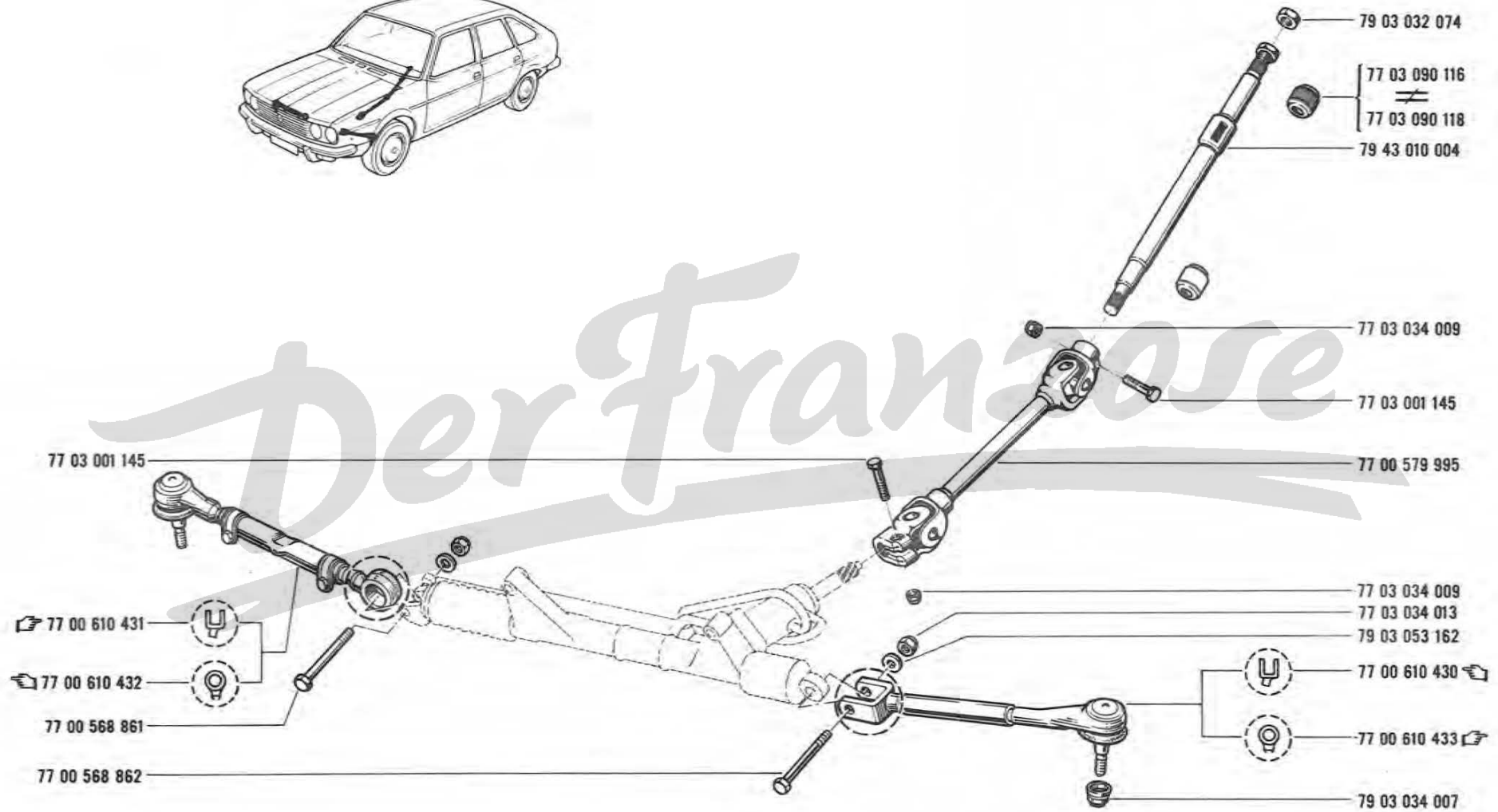
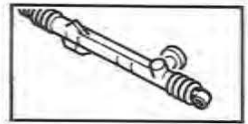

Der Franzose

36.40

A P.R.1030

36.40

A P.R.1030



6 77 00 618 572
8 77 00 618 573
13 77 00 618 571

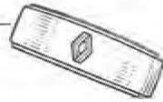

Der Franzose



77 00 618 566 6
77 00 618 567 8
77 00 618 565 13

37.01

A P.R.1030



37.01

A P.R.1030

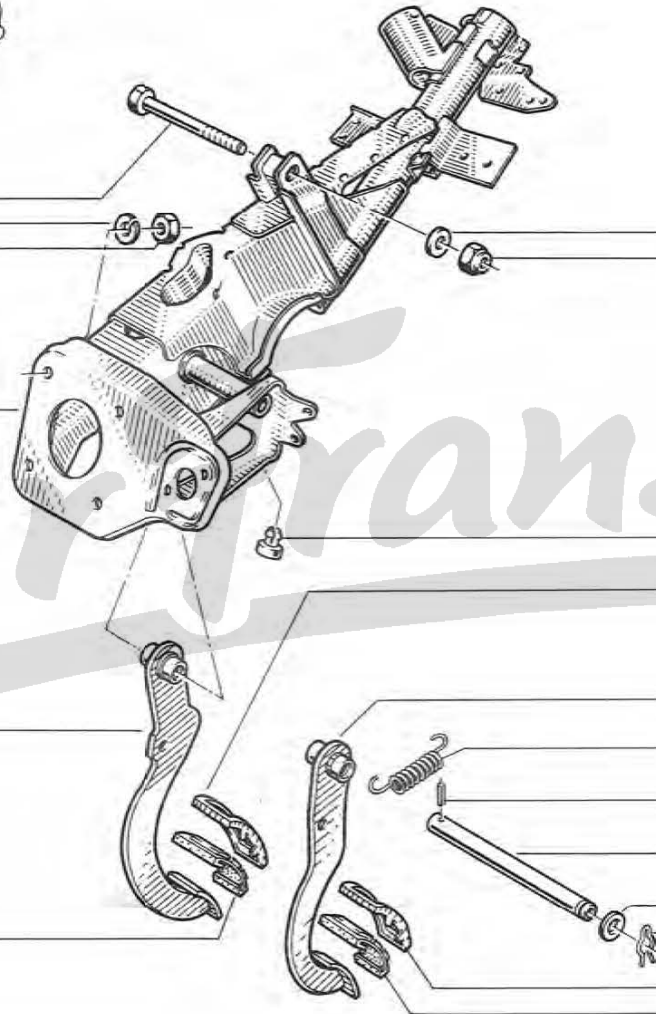
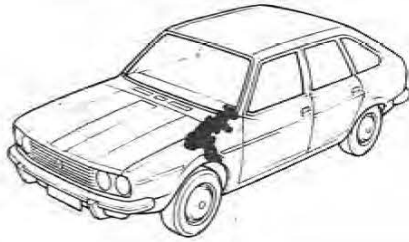
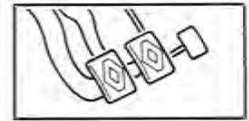

- ☒ 77 03 001 065
- ☒ 77 03 055 011
- ☒ 79 03 032 018

- 79 03 053 043 ☒
- 77 03 034 011 ☒

- ☛ 77 00 584 033
- ☛ 77 00 584 035

Der Franzose

- 06 08 107 500 ☛
- { 77 00 573 030 ☛
- { 77 00 590 051 ☛

- ☛ 77 00 580 071
- ☛ 77 00 580 065

- { 77 00 582 271
- { 77 00 582 273 } ☛
- 06 08 107 100

- ☛ 77 00 573 028
- ☛ 77 00 590 052

- 08 53 659 600
- { 77 00 582 501 ☛
- { 77 00 571 090 ☛
- 77 03 057 033 ☛
- 06 07 107 900
- 77 00 573 030 } ☛
- 77 00 573 028 } ☛

37.10

A PR.1030



37.10

A PR.1030

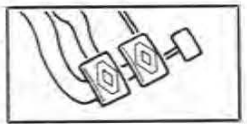

- ☒ 77 03 034 011
- ☒ 79 03 053 043
- ☒ 79 03 032 018
- ☒ 77 03 055 011

- 77 00 578 739
- 77 00 578 819

77 03 001 065

Der Franzose

06 08 107 500

77 00 577 158

77 00 573 030

06 08 502 407

08 53 659 600

77 00 567 137

77 00 571 090

06 07 107 900

77 00 573 028

77 00 577 160

77 00 575 028

77 00 573 030



37.20

A PR 1030

37.20

A PR 1030

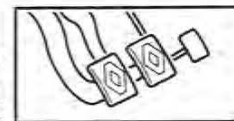

77 00 575 249
77 00 580 977

78 66 038 000
79 03 053 215
78 66 040 000
78 66 037 000

77 00 588 892

79 03 056 042
77 03 001 039
08 54 286 800

77 01 200 597

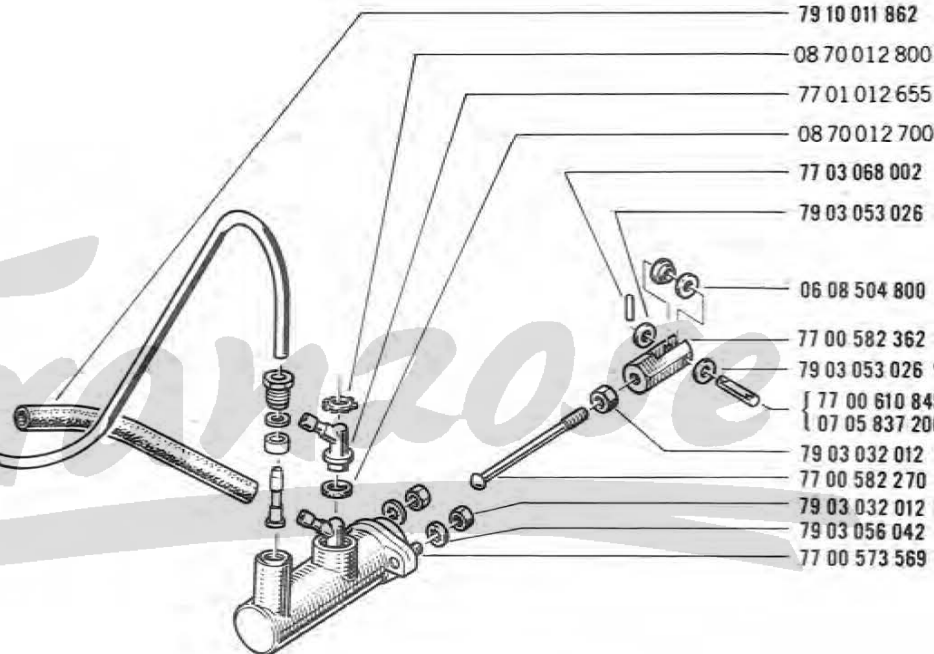
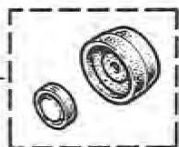

79 10 011 862
08 70 012 800
77 01 012 655
08 70 012 700
77 03 068 002
79 03 053 026
06 08 504 800
77 00 582 362
79 03 053 026
77 00 610 845
07 05 837 200
79 03 032 012
77 00 582 270
79 03 032 012
79 03 056 042
77 00 573 569

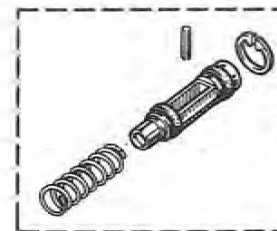

77 01 200 598

37.30

A P.R.1030



37.30

A P.R.1030

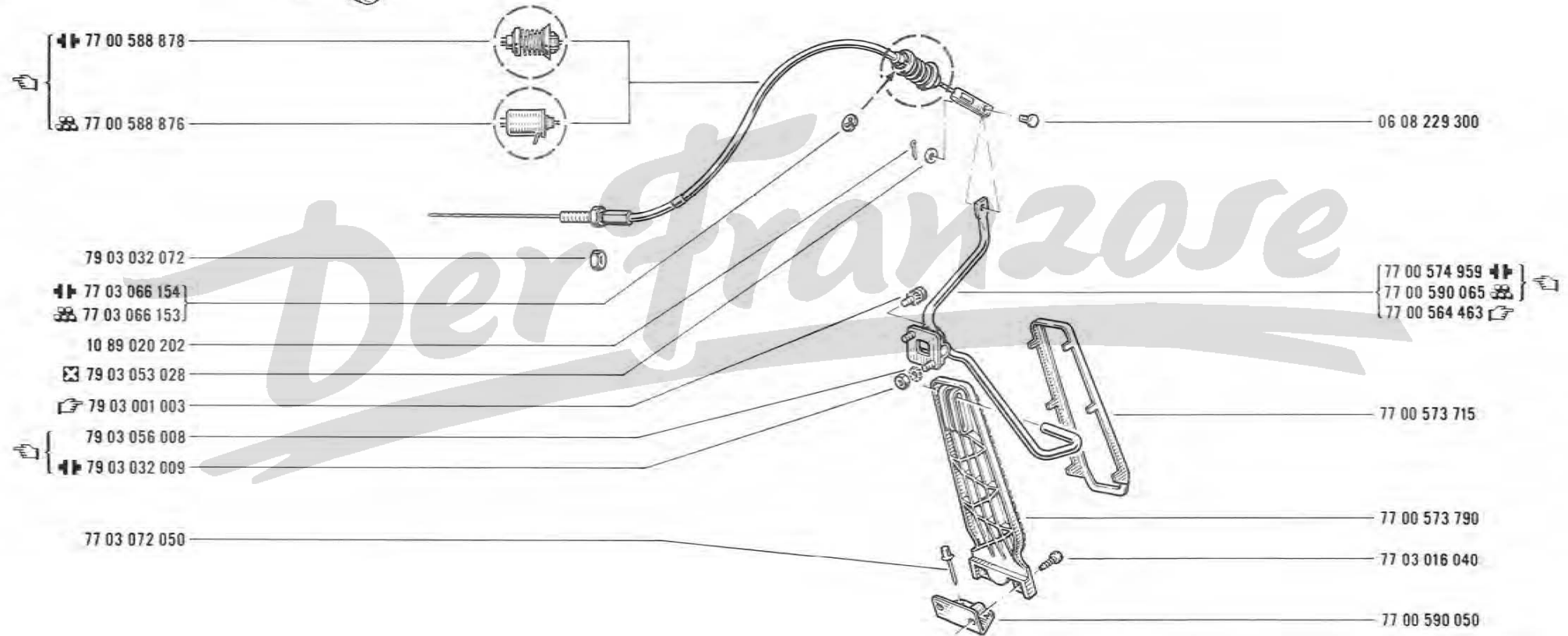
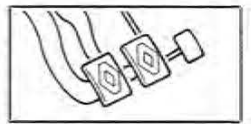

37.40
A P.R.1030

37.40
A P.R.1030

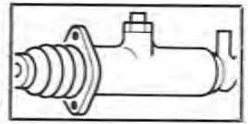

77 03 055 009

79 03 032 012

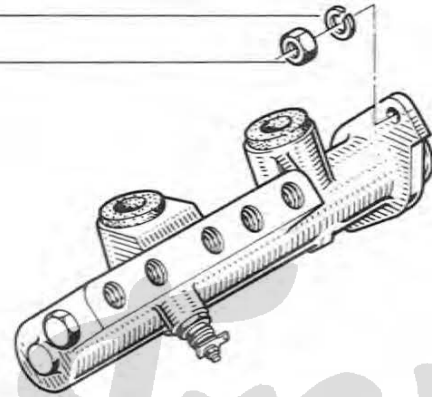

77 00 586 233

Der franzose

37.60
A PR 1030

37.60
A PR 1030

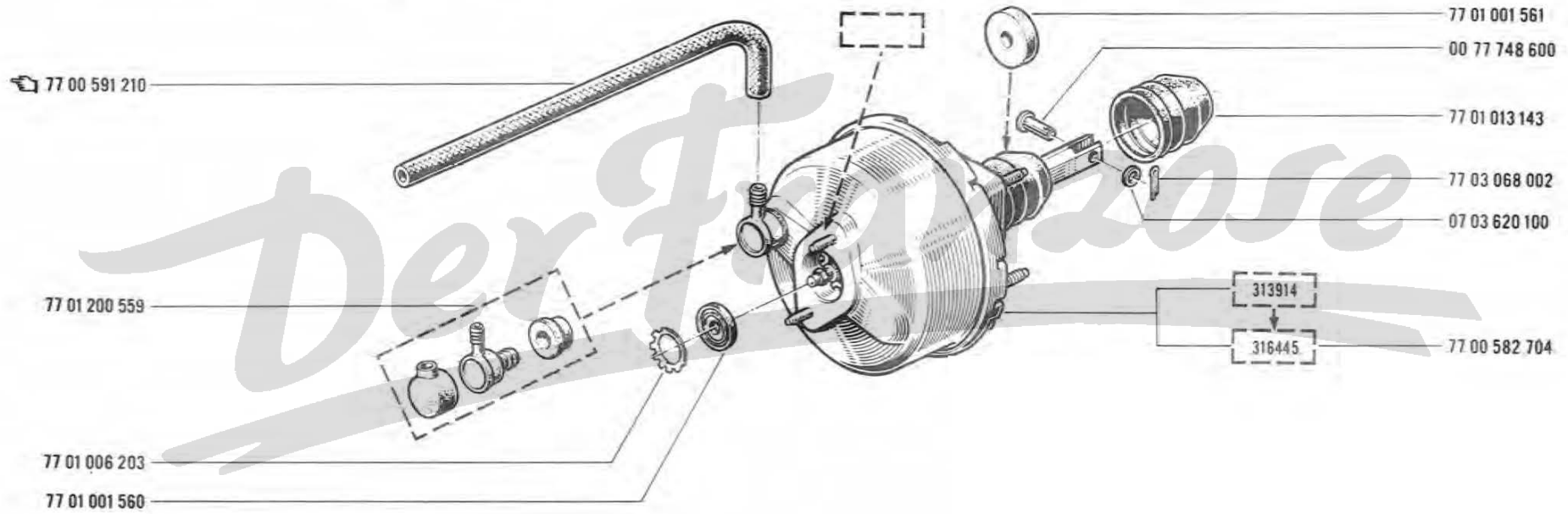
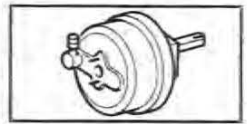

37.70
A P.R.1030

37.70
A P.R.1030

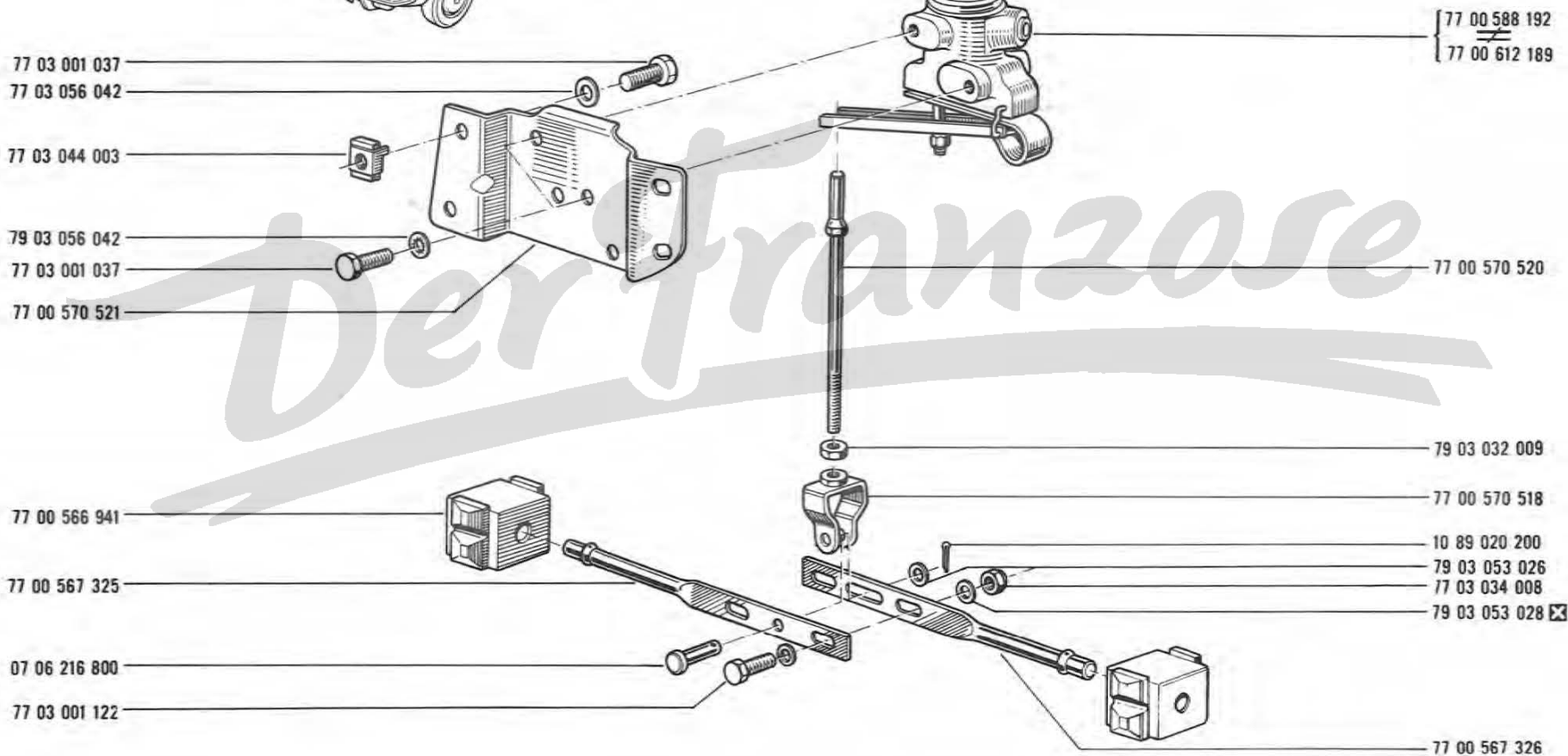
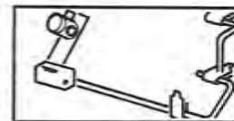

37.80

A PR 1030



37.80

A PR 1030

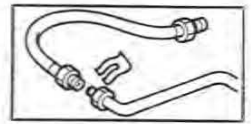

77 03 062 001

77 01 458 267

77 00 591 837

77 00 591 827

77 00 591 825

77 00 591 833

77 00 591 835

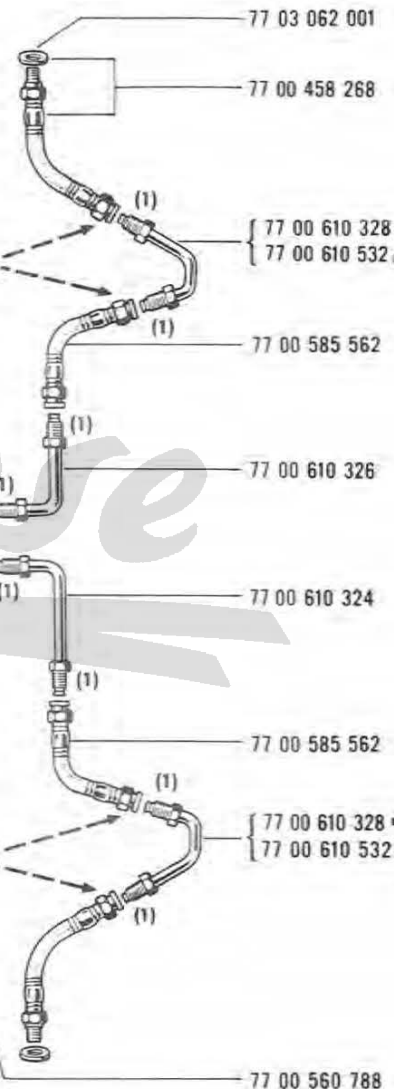
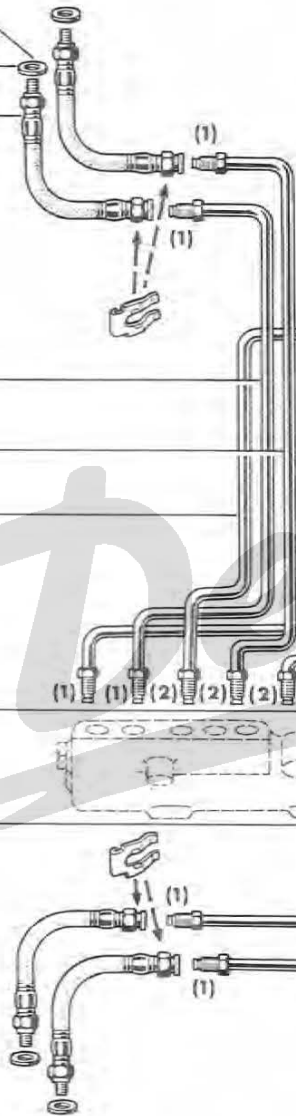
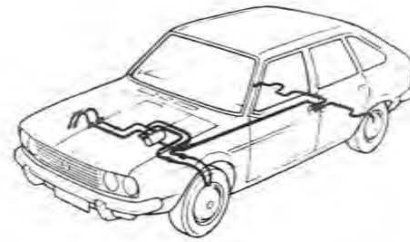

77 03 062 001

77 00 458 268

{ 77 00 610 328 4P
77 00 610 532 8P }

77 00 585 562

77 00 610 326

77 00 610 324

77 00 585 562

{ 77 00 610 328 4P
77 00 610 532 8P }

77 00 560 788

tor Franze

(1)	(2)
77 00 539 476	77 00 584 760

38.01

A P.R.1030

38.01

A P.R.1030

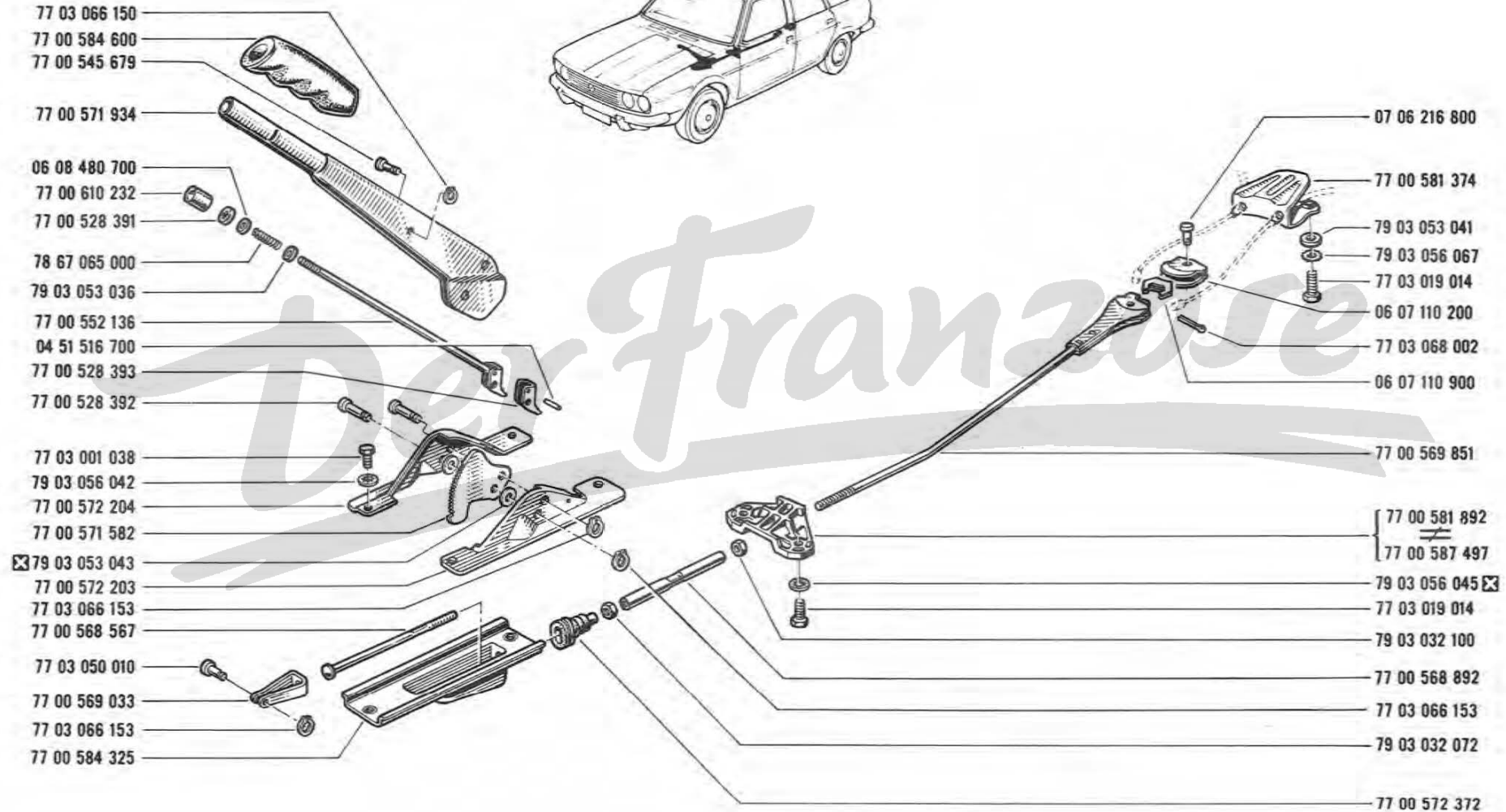

38.20

A P.R.1030



38.20

A P.R.1030



77 00 560 211
77 03 066 080
77 00 576 911

77 03 034 044

77 00 588 083
77 00 585 736
77 03 058 008
77 03 001 165
77 03 001 054
77 03 058 008

77 00 587 665

77 00 577 954
79 03 053 041
77 03 034 046
77 00 587 662
77 03 034 044

{ 77 00 613 930 5
77 00 588 777 13 }

77 03 001 140

79 03 056 040

77 00 577 543

79 03 056 040

77 03 053 036

77 03 019 005

77 00 560 125

77 00 561 463

77 03 057 009

50 03 066 039

77 00 560 121

77 00 579 240

77 03 066 137

77 00 561 464

77 00 575 465

Der Franzose

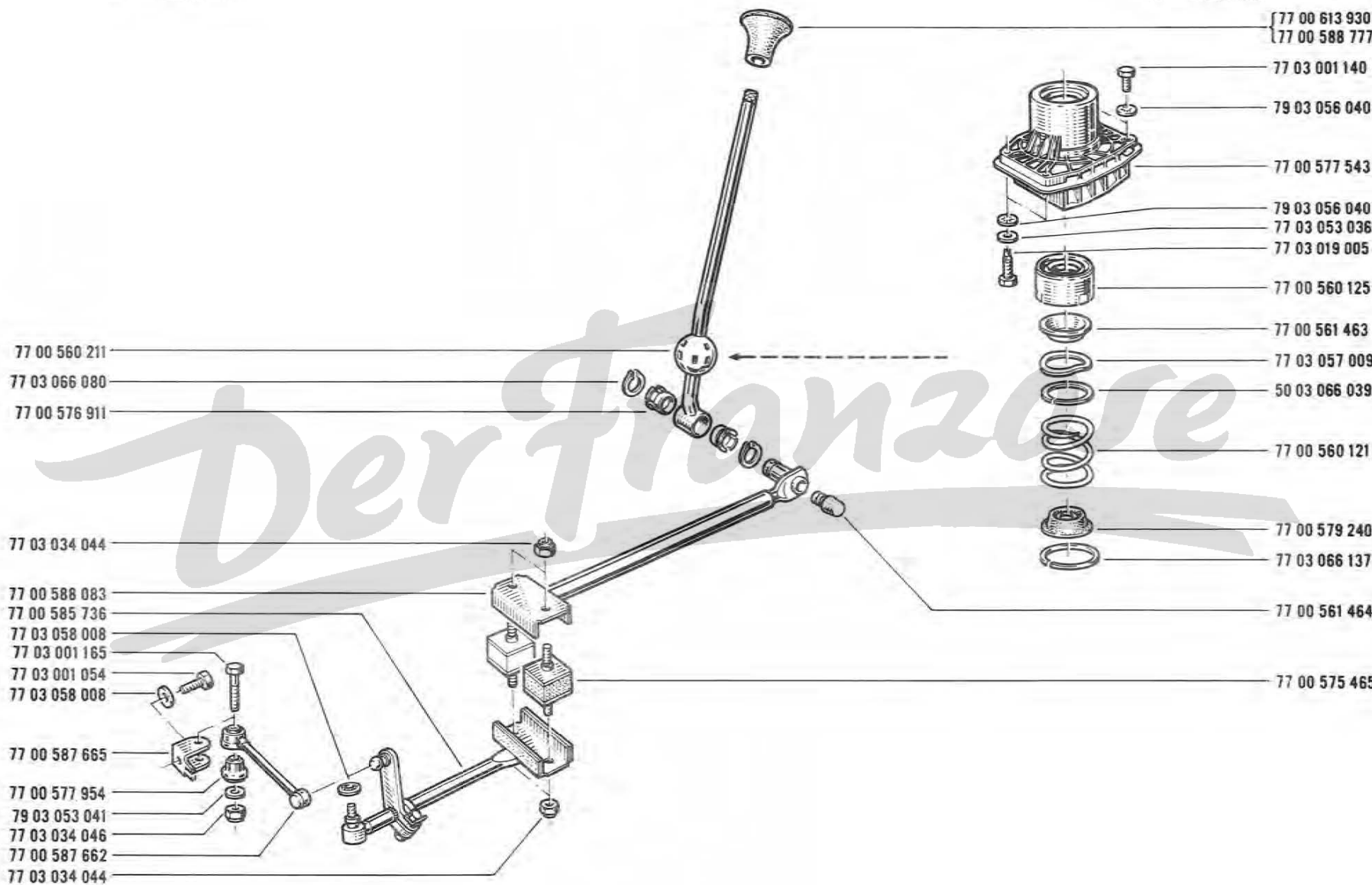

38.30

A P.R.1030



38.30

A P.R.1030

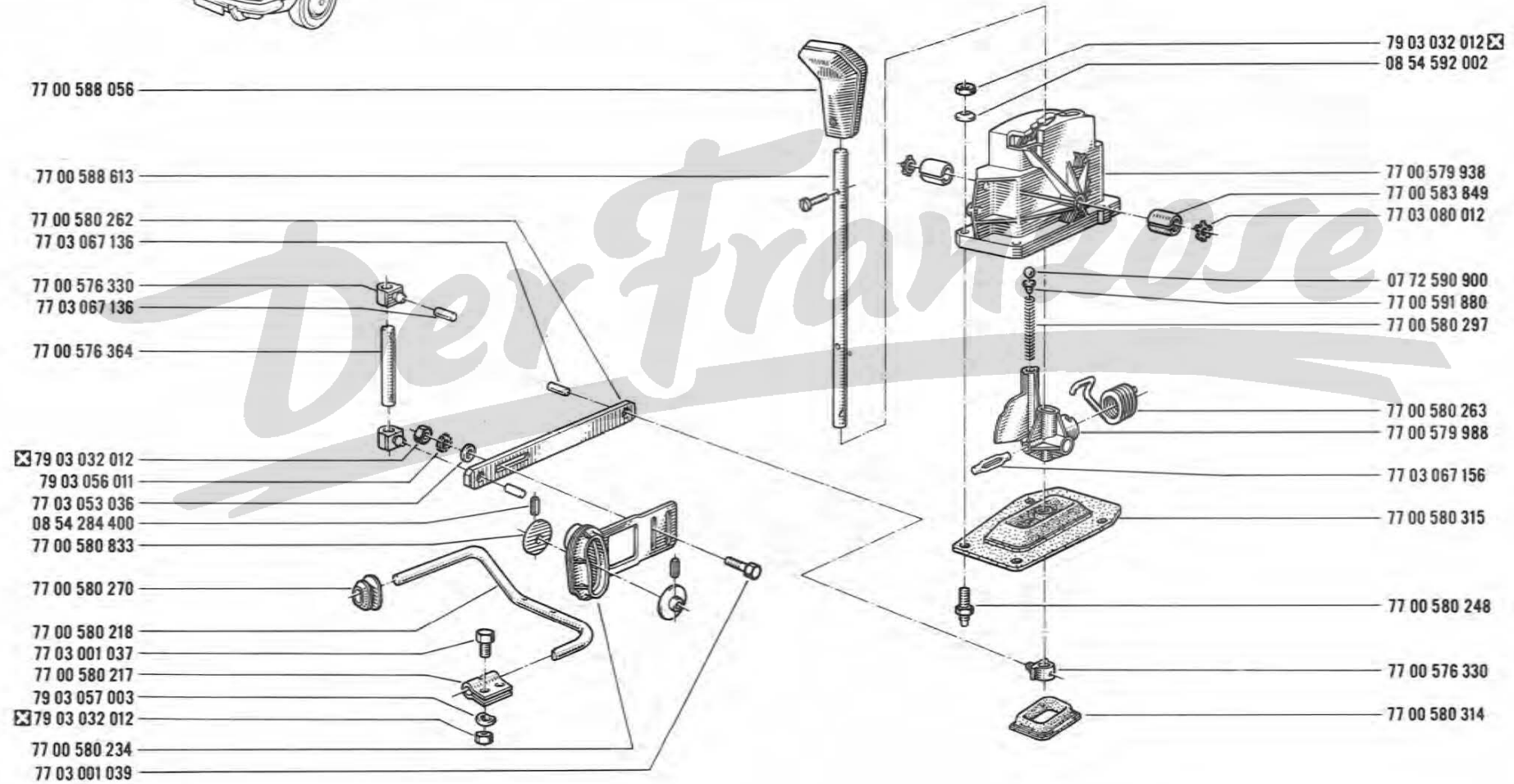
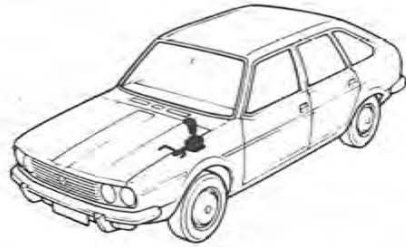
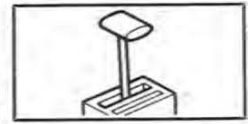

40.01

A P.R.1030

40.01

A P.R.1030

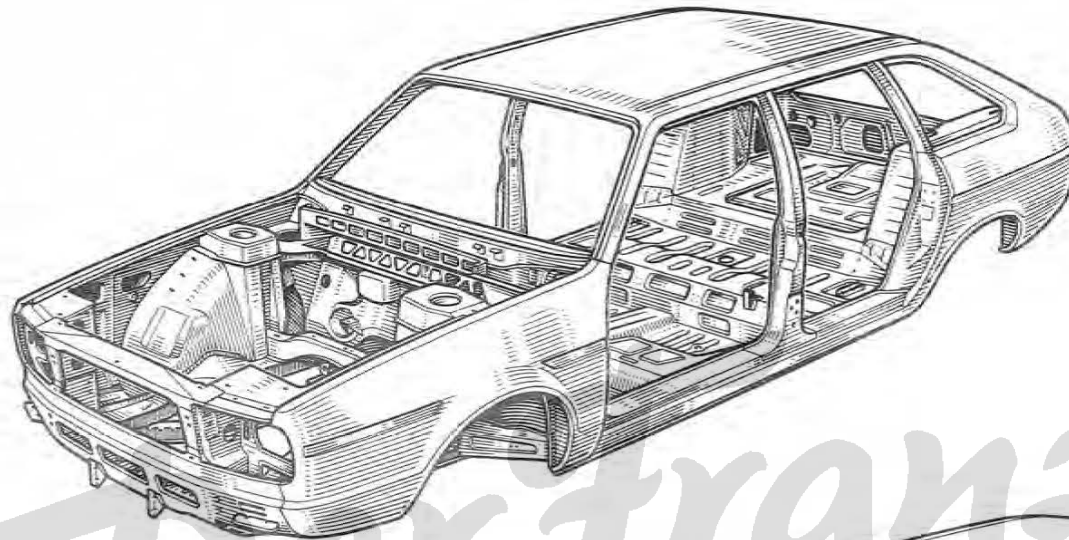
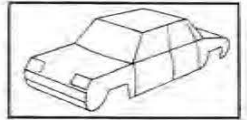

- 77 01 458 431
- 77 01 458 432
- 77 01 458 433
- 77 01 458 434

Der Franzose

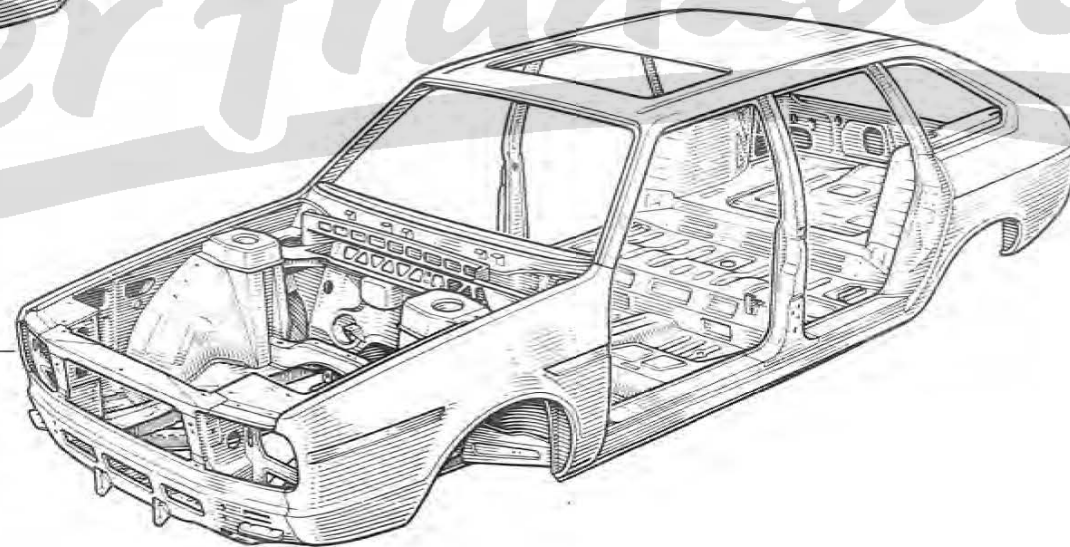

- 77 01 458 435
- 77 01 458 436
- 77 01 458 437
- 77 01 458 438

40.10
A P.R.1030

40.10
A P.R.1030

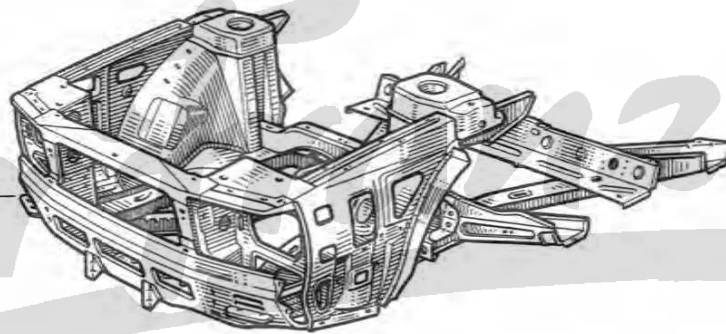

77 01 535 043

Derivazione



41.10

A P.R.1030

41.10

A P.R.1030

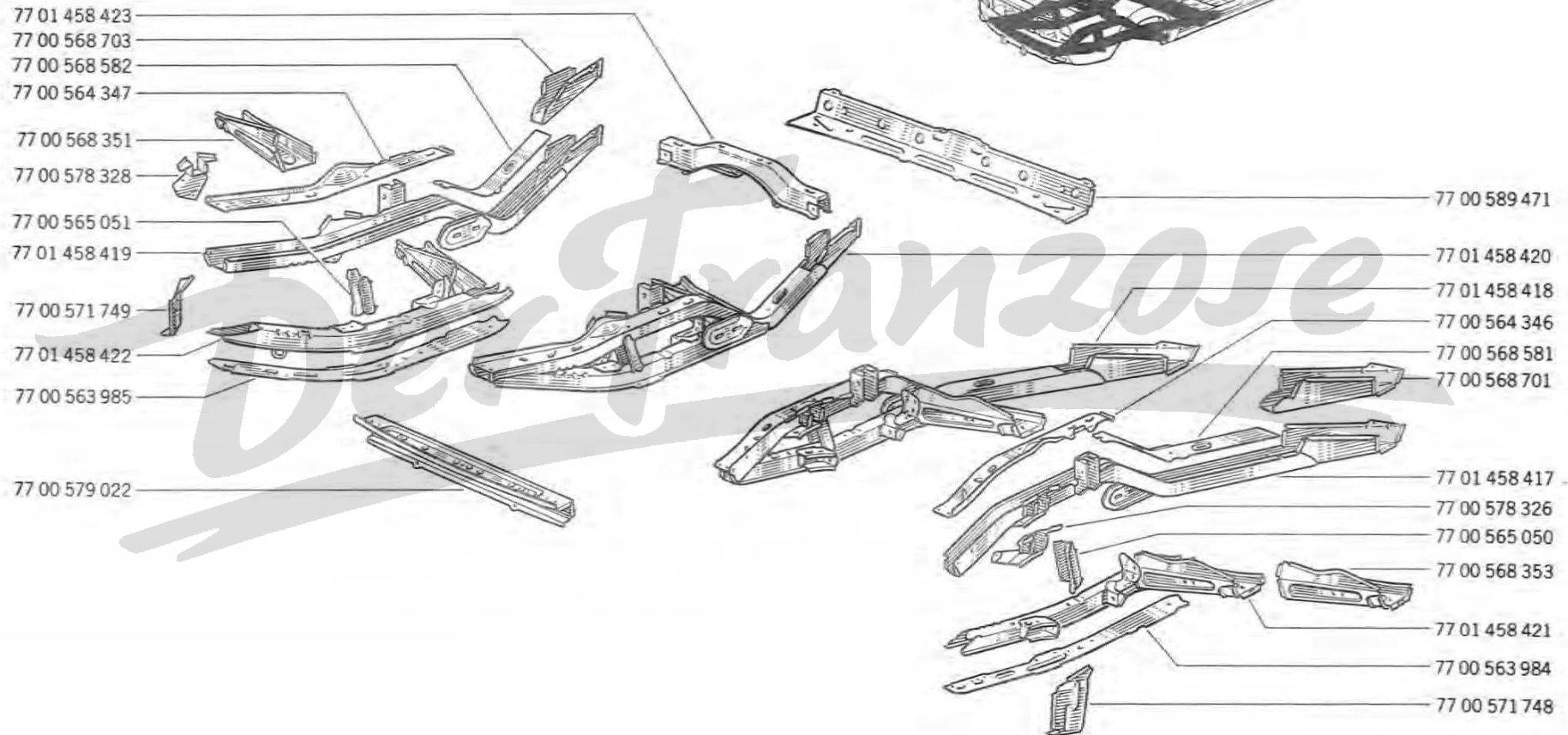
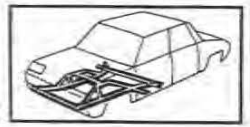

41.20
A P.R.1030

41.20
A P.R.1030

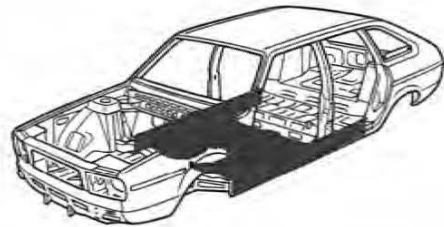
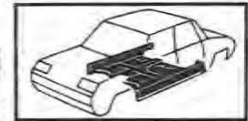

77 00 569 223

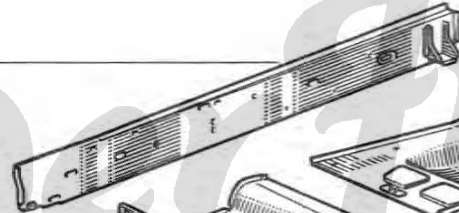

77 00 566 257

77 00 568 408

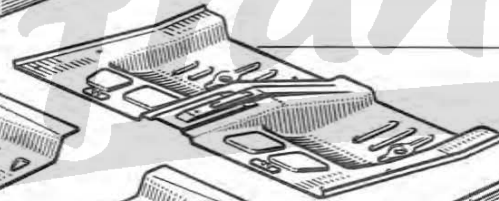

77 00 568 407

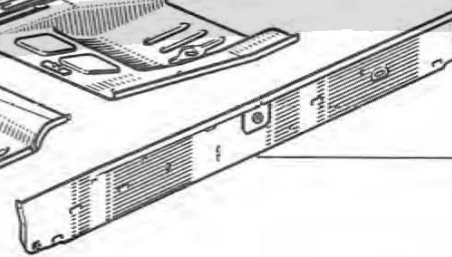

77 00 569 221

DeFranzose



41.30
A P.R.1030

41.30
A P.R.1030

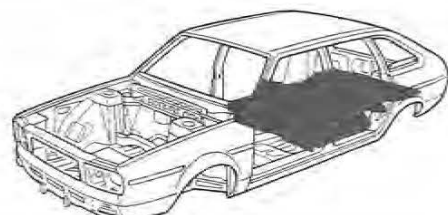
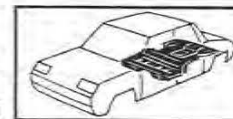

77 00 577 701



77 00 566 023

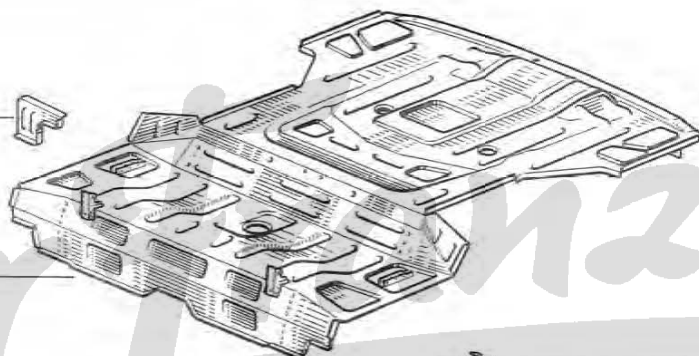

77 00 579 929

77 00 579 822

77 01 458 427

77 01 458 424

77 01 458 425

77 01 458 426



Derivazione

42.01

A P.R.1030

42.01

A P.R.1030

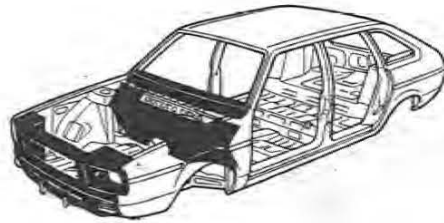

77 00 570 066

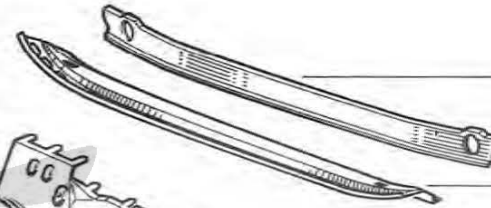
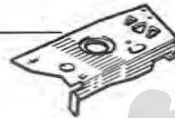

77 00 570 241
77 00 570 243

77 00 568 804

77 01 534 979

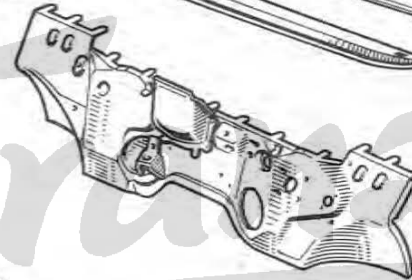

77 00 567 698
77 00 575 042

77 01 519 799

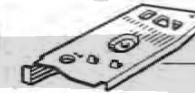
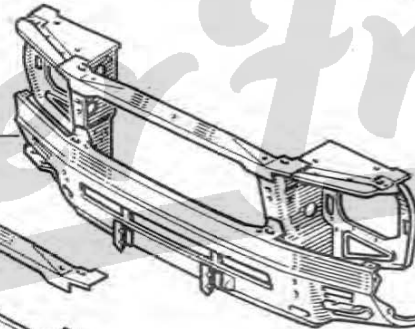

77 00 570 068

77 00 568 366

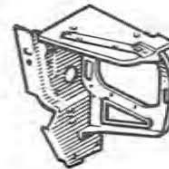
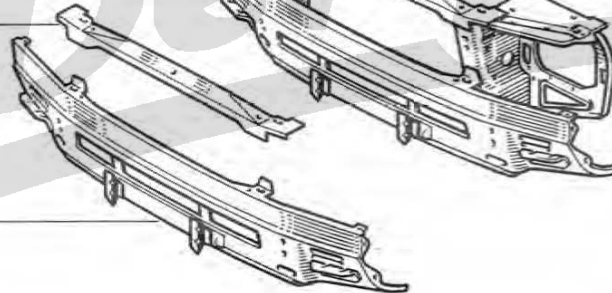

77 01 534 978

77 00 567 454

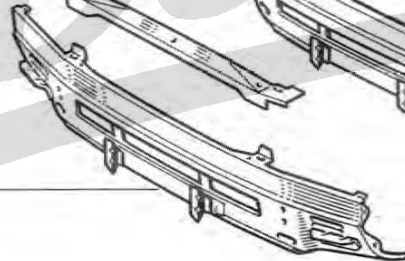

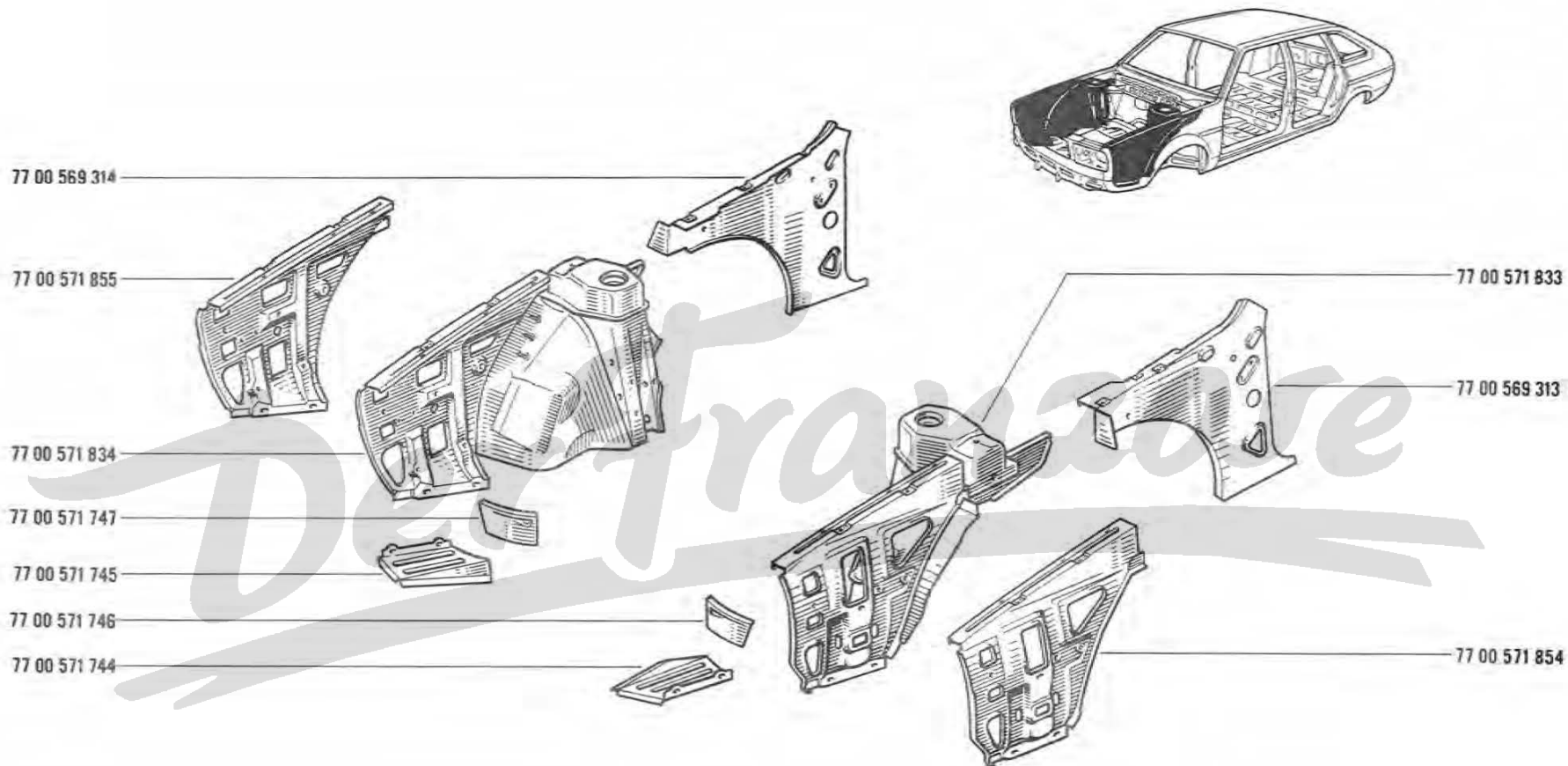

43.01

A P.R.1030

43.01

A P.R.1030

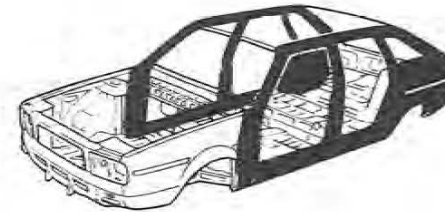
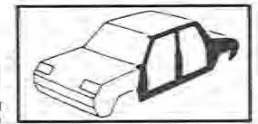

77 00 566 327

77 00 566 483

77 00 567 989

77 01 531 708

77 00 569 312

77 00 569 308

77 00 566 712

77 01 519 384

77 00 569 484

77 00 569 311

77 00 569 483

77 01 519 383

77 00 569 307

77 00 566 481

77 00 567 986

77 00 578 996

77 00 566 711

77 01 531 703



44.01
A PR 1030

44.01
A PR 1030

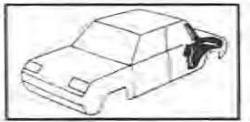

77 00 570 206

77 00 571 279

77 01 531 710

77 01 519 388

77 01 519 387

77 00 579 438

77 00 567 206

77 00 579 437

77 00 567 207

77 00 570 204

77 01 531 705

77 00 571 391



44.20

A P.R.1030

44.20

A P.R.1030

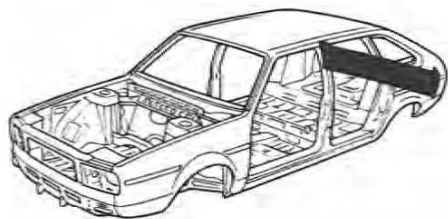
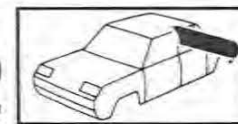

77 00 580 967

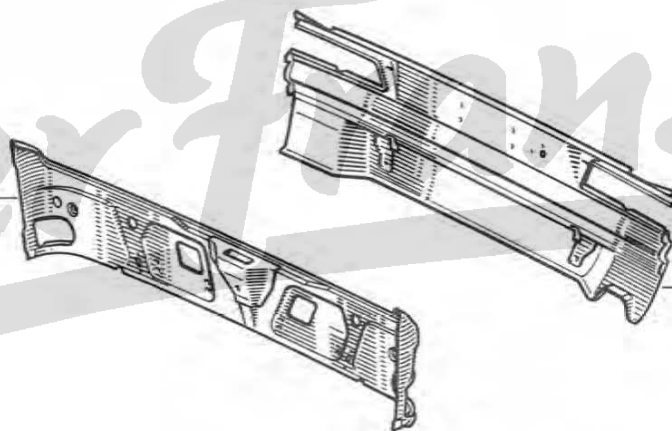

77 00 565 564

Dex France



45.01

A P.R.1030

45.01

A P.R.1030



77 00 566 357

77 00 566 935

77 00 569 833

77 00 567 541

77 00 573 379

77 03 001 020

79 03 056 037

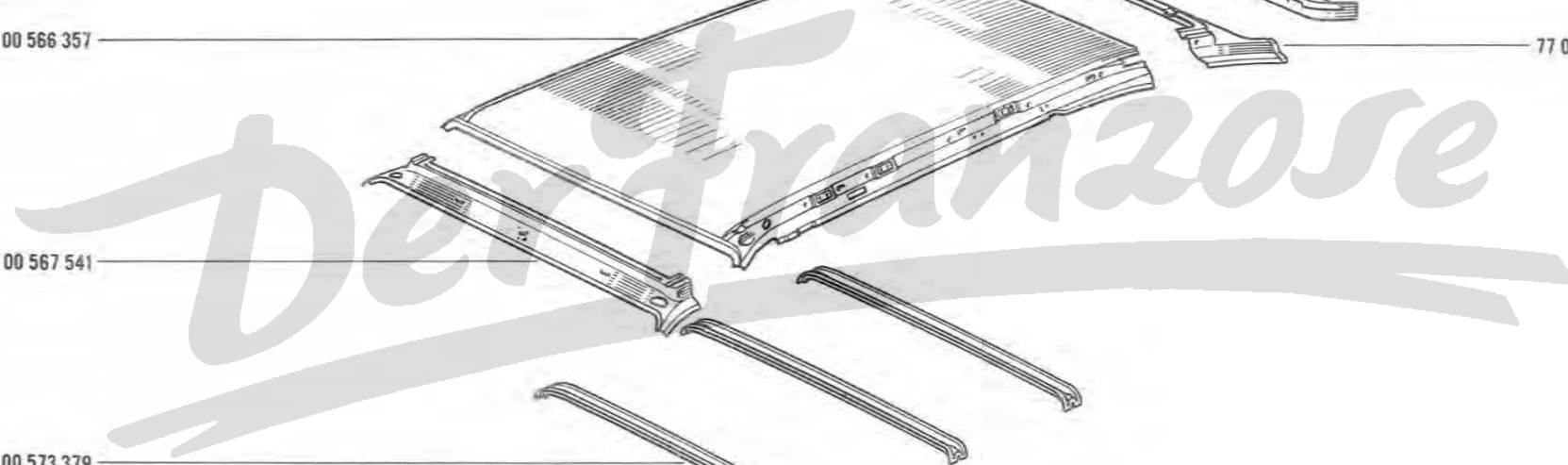

Derfranzose

46.01
A P.R.1030

46.01
A P.R.1030

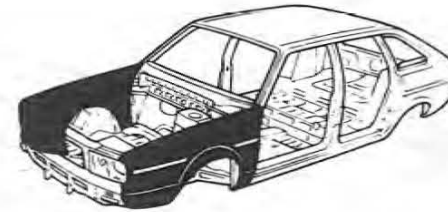

77 00 570 224

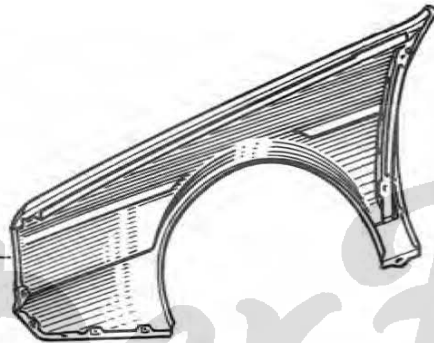

77 00 570 223

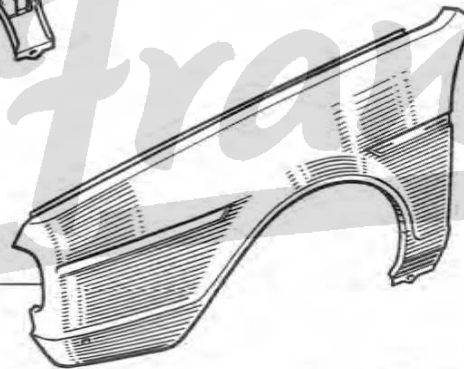

77 03 016 144

79 03 053 035

77 03 046 012 ☒

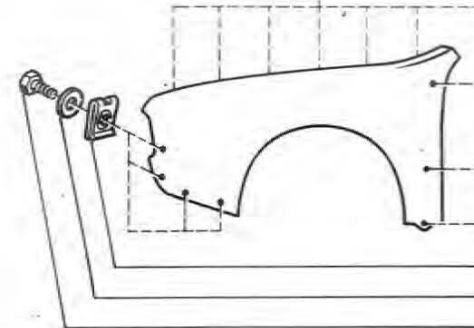

77 03 046 007

79 03 053 035

77 03 016 144

Der Franzose

46.10

A P.R.1030

46.10

A P.R.1030

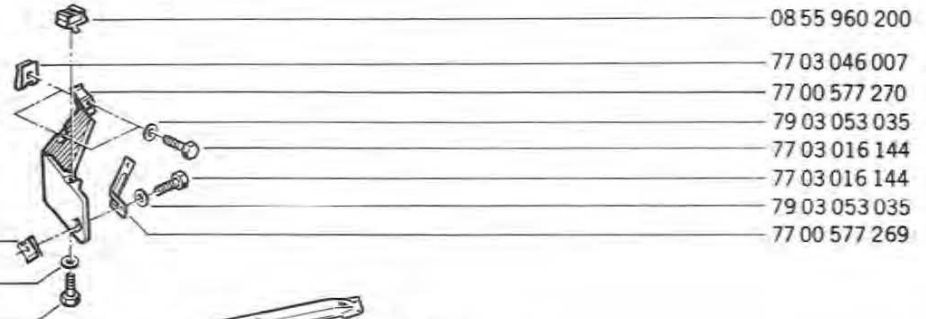
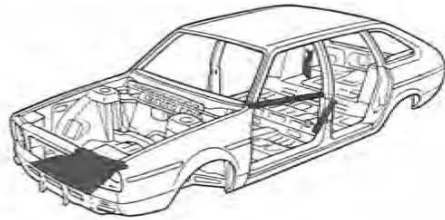
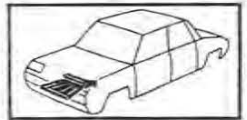

- 77 03 046 007
- ☒ 79 03 053 031
- 77 03 001 022

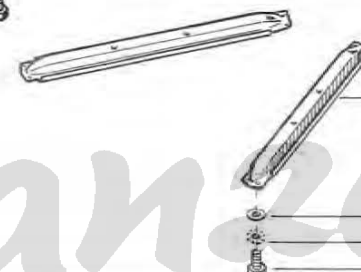

77 00 566 333

- 77 03 032 007
- 79 03 056 068
- 77 00 573 258
- 77 03 046 031
- 77 03 088 003
- 77 03 046 031

- 79 03 053 041
- 79 03 056 014
- 77 03 019 014
- 79 03 056 017 ☒
- 79 03 053 050 ☒

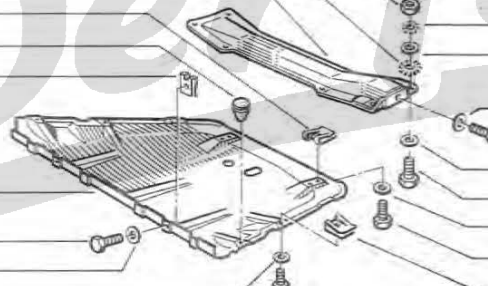

- 77 00 574 776
- 77 03 016 144
- ☒ 79 03 053 157
- ☒ 79 03 053 157
- 77 03 016 144

- 79 03 053 050 ☒
- 77 03 001 196
- 79 03 053 050 ☒
- 77 03 001 674
- 79 03 053 157 ☒
- 77 03 016 144
- 77 03 046 031



Dex Franze

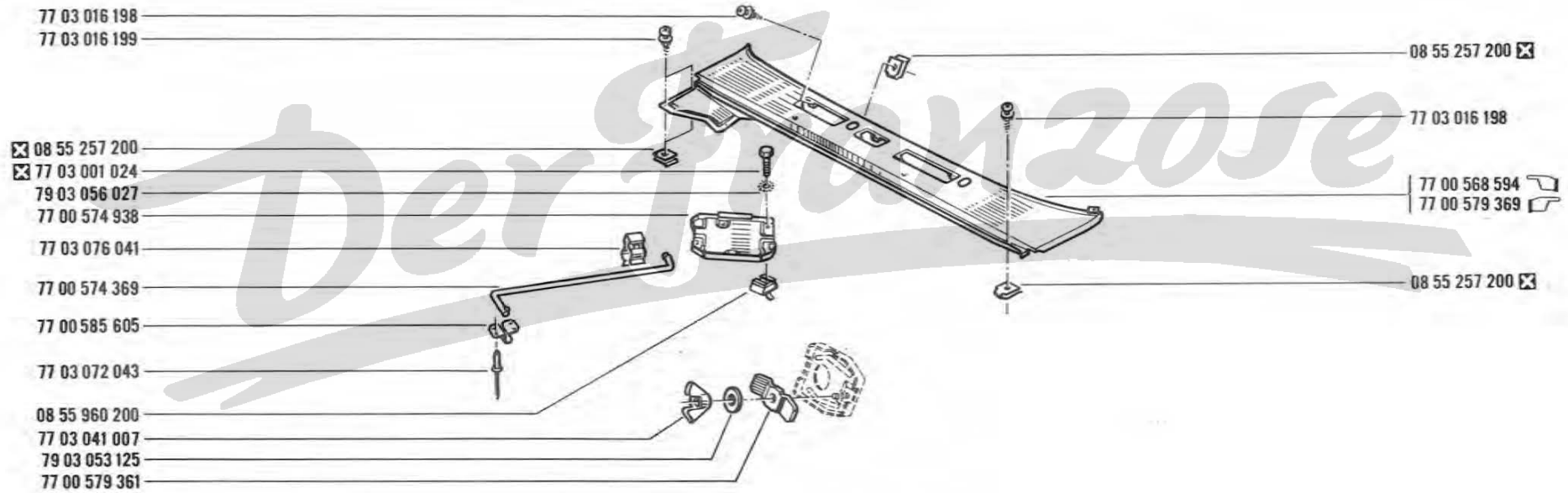
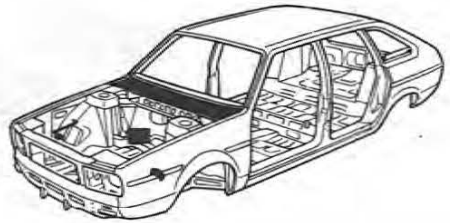

47.01

A P.R.1030

47.01

A P.R.1030



77 00 583 937

77 01 533 082

77 01 532 792

77 00 583 945

77 00 583 936

77 01 533 081

77 01 532 789

77 00 583 942

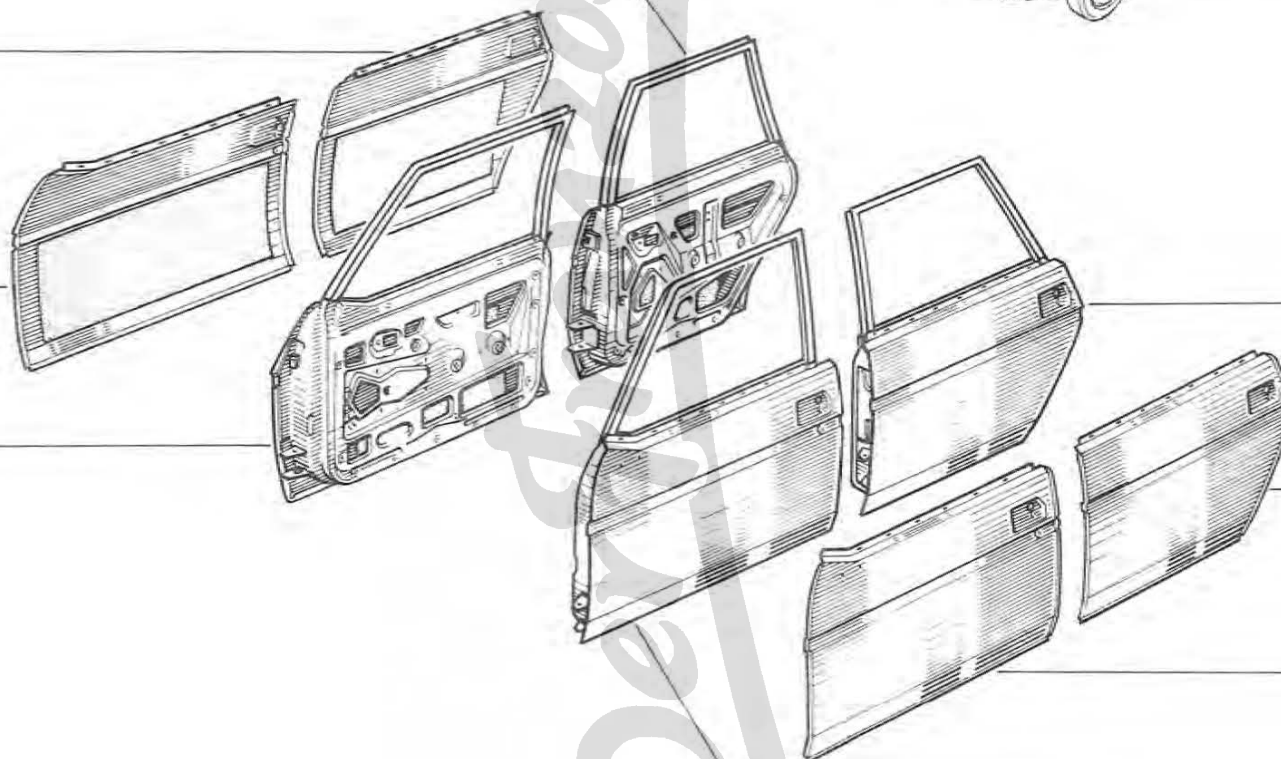

48.01

A P.R.1030

48.01

A P.R.1030

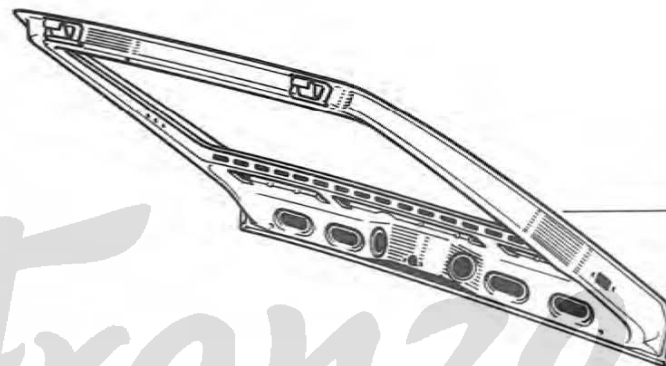

77 01 533 087

77 01 458 308

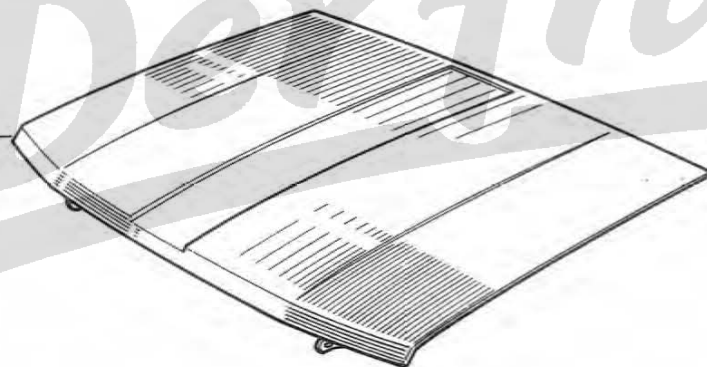

Der Franzose

50.15

A P.R.1030

50.15

A P.R.1030

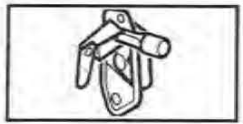

77 01 018 446

77 00 586 201

77 01 018 443

77 01 017 938

77 01 017 939

77 00 577 707

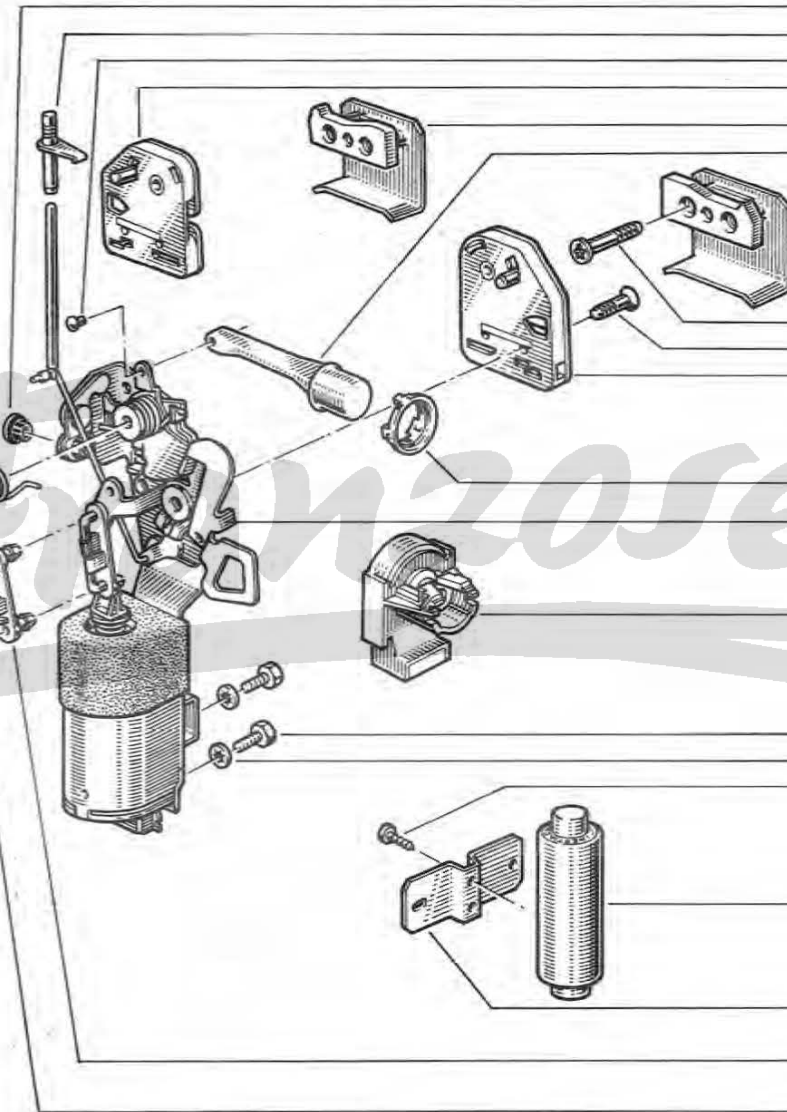

- 77 01 018 447
- 77 00 572 233
- 08 52 851 900
- 77 00 587 337
- 77 00 587 339
- 77 00 572 838
- 77 00 587 340
- 77 03 004 082
- 77 03 004 073
- 77 00 587 338
- 77 00 565 962
- 77 00 586 200
- 77 00 577 474
- 77 03 001 668
- 79 03 056 036
- 77 03 016 008
- 77 00 549 188
- 77 00 581 426
- 77 00 581 427
- 77 01 018 445
- 77 01 018 444



50.25

A P.R. 1030

50.25

A P.R. 1030



77 00 587 339
08 52 851 900
77 00 572 233
77 00 587 337

77 01 018 470

77 00 586 197

77 01 018 447

77 01 018 469

77 00 586 196

79 03 056 036

77 03 001 668



77 01 018 471
77 00 572 836

77 00 587 340

77 03 004 082

77 03 004 073

77 00 587 338

77 00 565 962

77 01 018 445

77 01 018 444

77 01 017 938

77 01 017 939

77 00 577 707

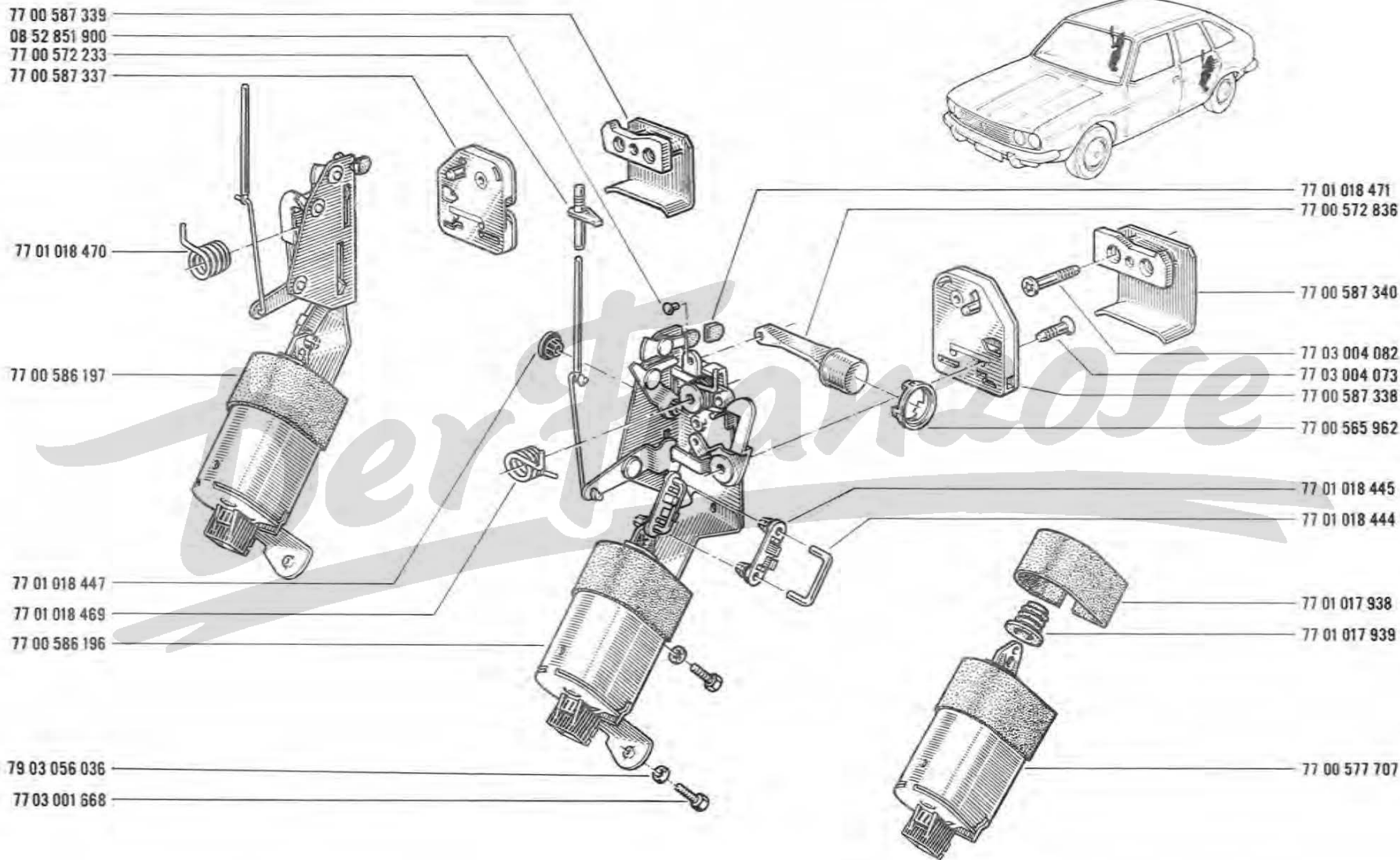

50.40
A P.R.1030

50.40
A P.R.1030



ber Franzose

77 01 458 389
77 01 458 391

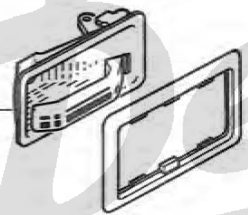

77 00 572 232
77 00 613 458



77 00 572 231
77 00 613 459



77 03 016 169

77 00 611 605

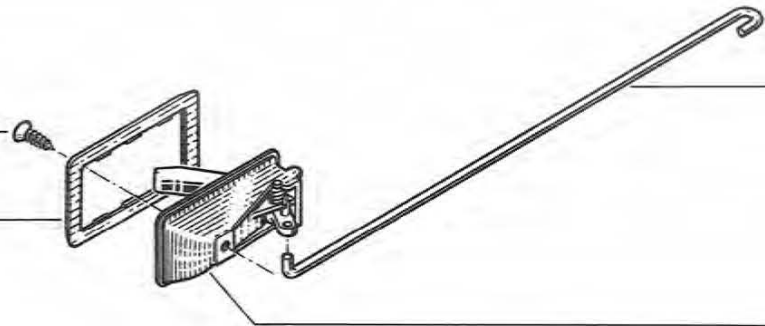

77 00 571 993

77 01 458 390
77 01 458 392

50.50
A PR.1030

50.50
A PR.1030



Der Franzose

25 77 01 458 389
5 77 01 458 391

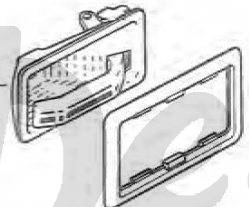

25 77 00 572 232
5 77 00 613 458

25 77 00 572 231
5 77 00 613 459

77 03 016 169

77 00 611 605

77 01 458 390 25
77 01 458 392 5

77 00 571 993

77 00 571 995

77 00 571 998

77 00 571 982

77 00 571 992

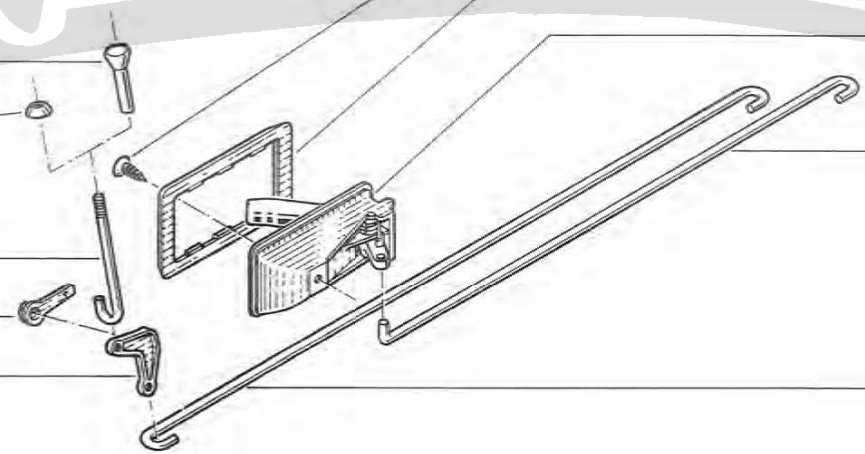

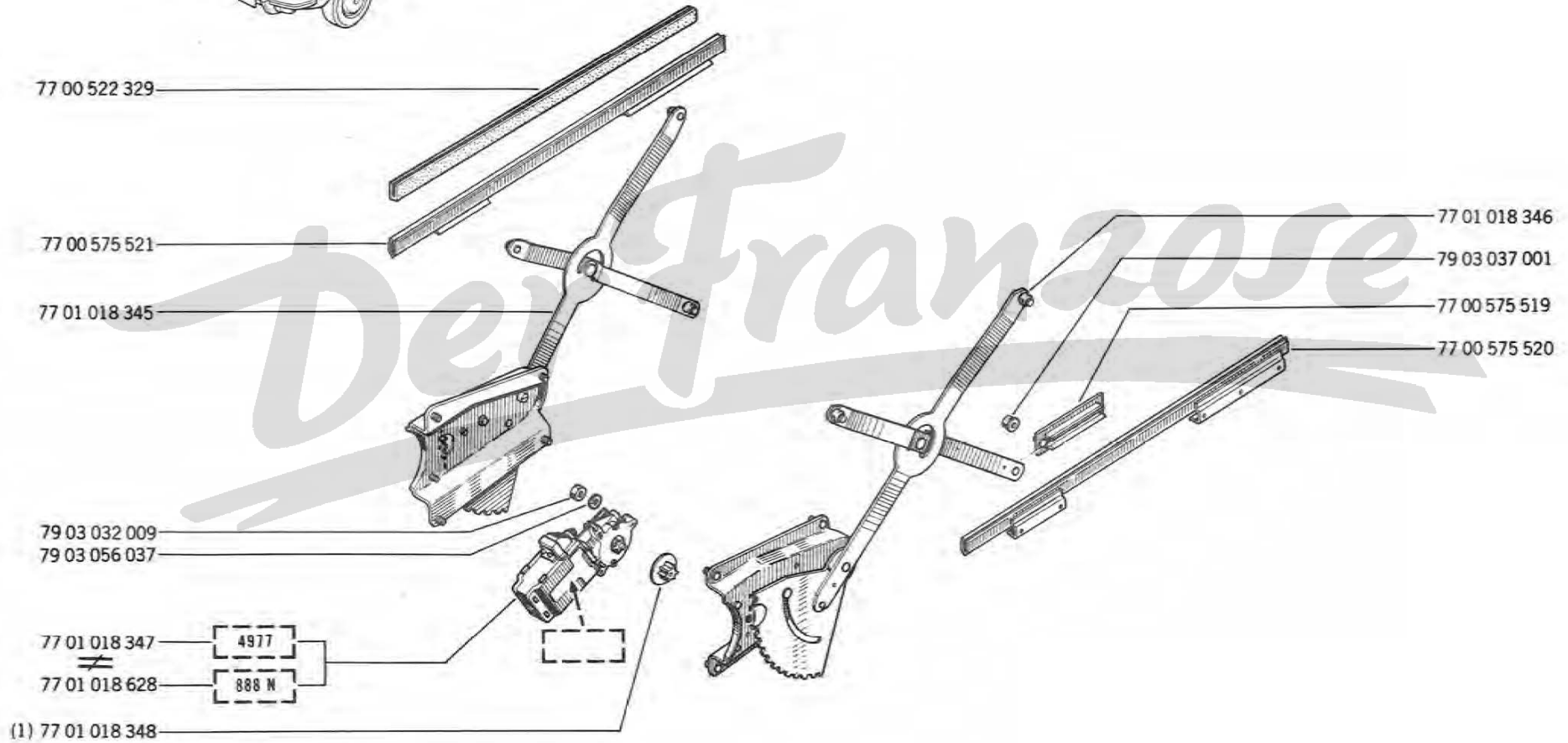



77 00 575 660

77 00 575 664

- 79 03 037 001
- 25 77 00 573 805
- 5 77 00 589 362
- 25 77 00 572 306
- 5 77 00 613 460
- 06 04 346 300
- 77 03 037 001

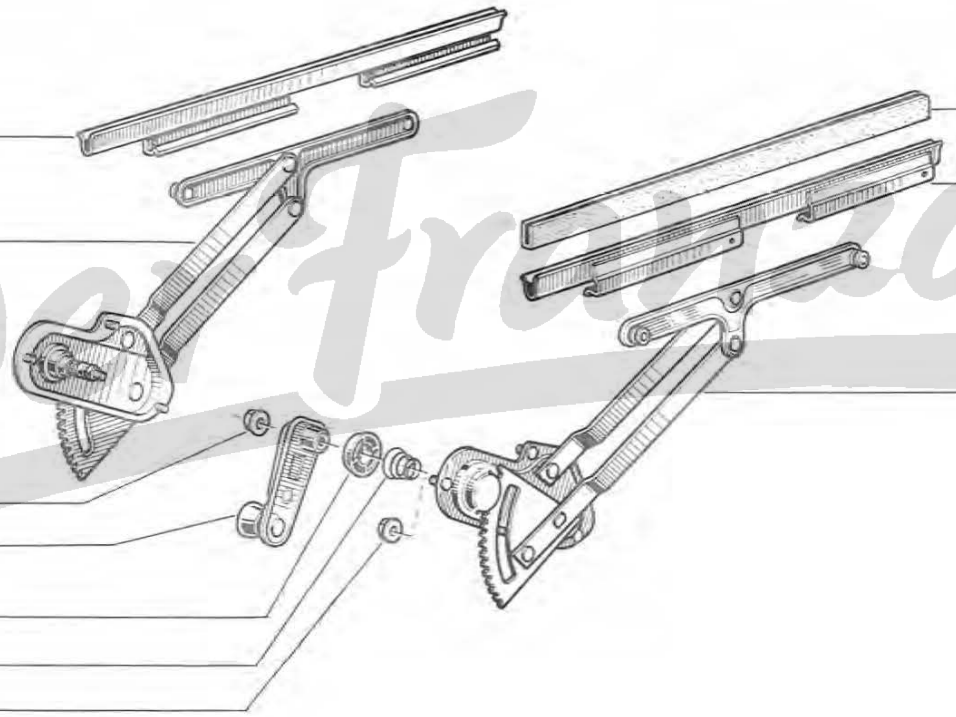

77 00 572 886

77 00 575 659

77 00 575 663

DeFranzose

52.01

A P.R.1030

52.01

A P.R.1030

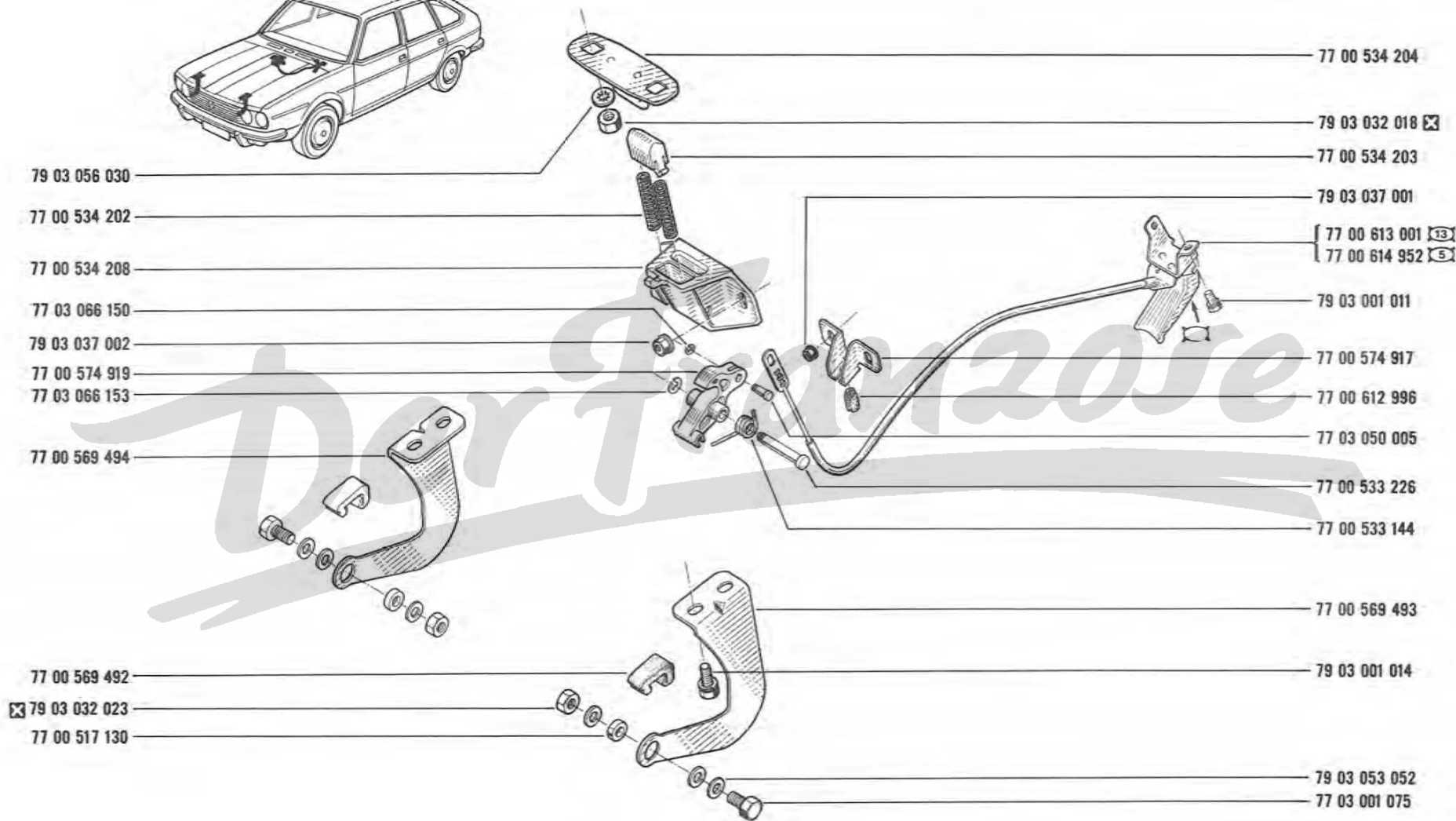
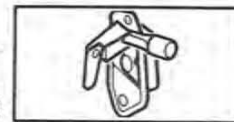

52.20

A P.R.1030

52.20

A P.R.1030

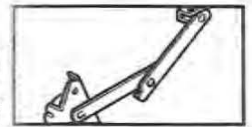

77 03 056 039

77 00 578 167

77 00 578 160

77 00 571 206

79 03 037 002

77 00 571 205

[A=1] 77 00 571 209

[A=2] 77 00 571 210

77 00 571 437

79 03 053 048

79 03 037 002

08 53 561 300

79 03 001 011

73 65 732 006

77 00 582 004

77 00 571 600

79 03 037 001

77 03 001 761

77 00 580 388

[77 00 581 345 (B=1)

[77 00 581 346 (B=2)

77 00 578 166

77 01 018 842

77 00 578 159

77 03 056 039

77 03 009 071

77 03 066 154



Derfranzose

53.01

A P.R.1030

53.01

A P.R.1030

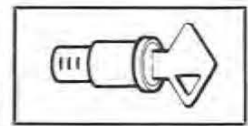

77 00 582 617

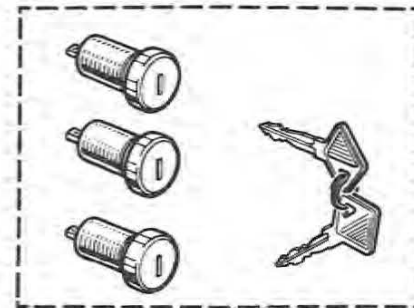
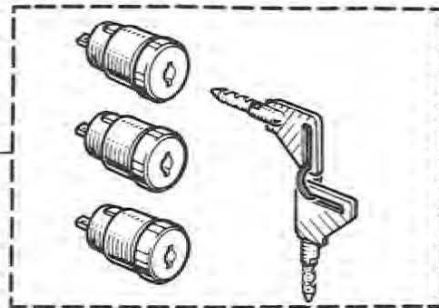

77 00 582 618

77 03 067 138

77 00 570 069

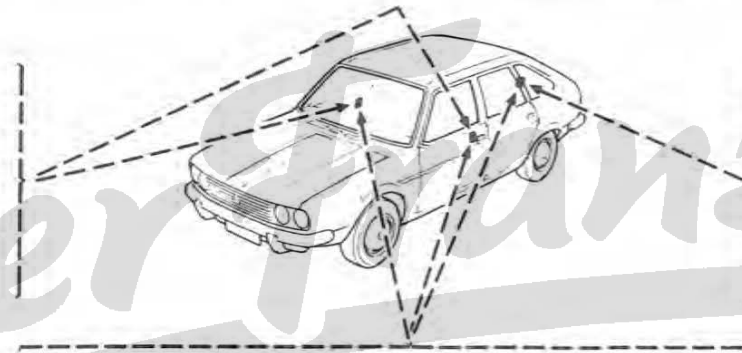
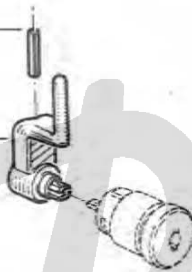

77 03 067 138

77 00 582 003

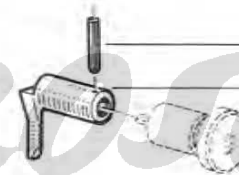

77 01 018 140
(1) & 77 01 018 141

77 01 018 138
(1) & 77 01 018 139

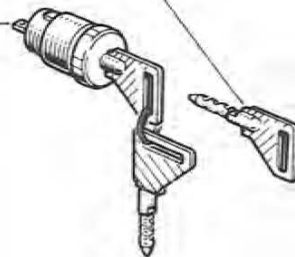

77 01 018 142
77 01 018 143 & (1)

77 01 018 145
77 01 018 144 & (1)

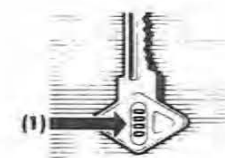
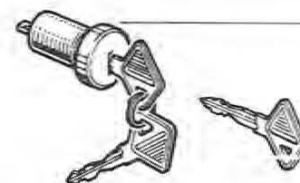



54.01



A P.R. 1030

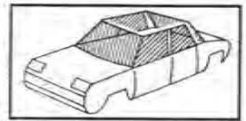

54.01

A P.R. 1030





(1)  77 00 570 201
 77 00 581 502



(1)  77 00 568 760
 77 00 581 241



(1)  77 00 568 933
 77 00 581 245

77 00 576 589  (1)
77 00 585 557 

77 00 570 200  (1)
77 00 581 501 

77 00 568 759  (1)
77 00 581 240 

(2)  77 00 569 329
(3)  77 00 581 242

77 00 568 932  (1)
77 00 581 244 

(1) SECURIT

(2) TRIPLEX SUPER

(3) TRIPLEX

55.01

A P.R. 1030

55.01

A P.R. 1030

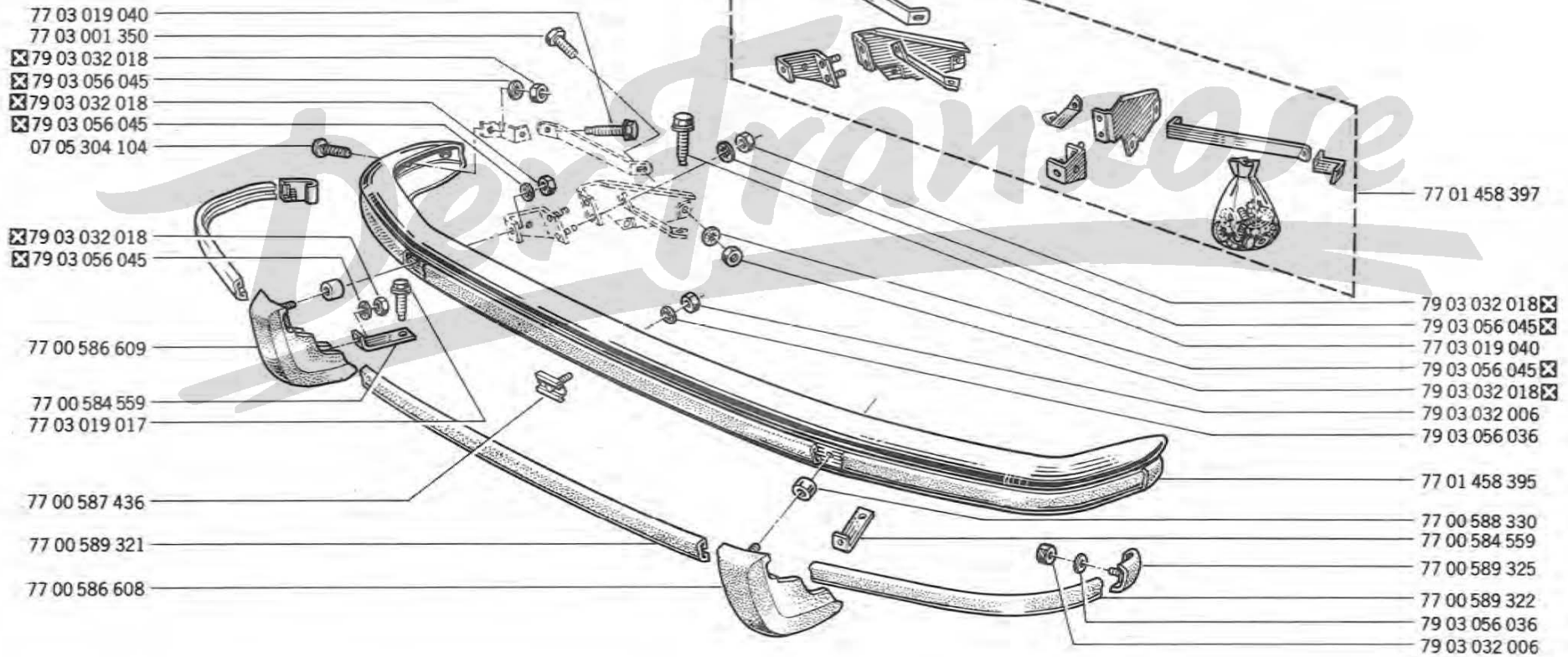
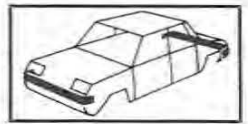

55.10

A P.R. 1030

55.10

A P.R. 1030

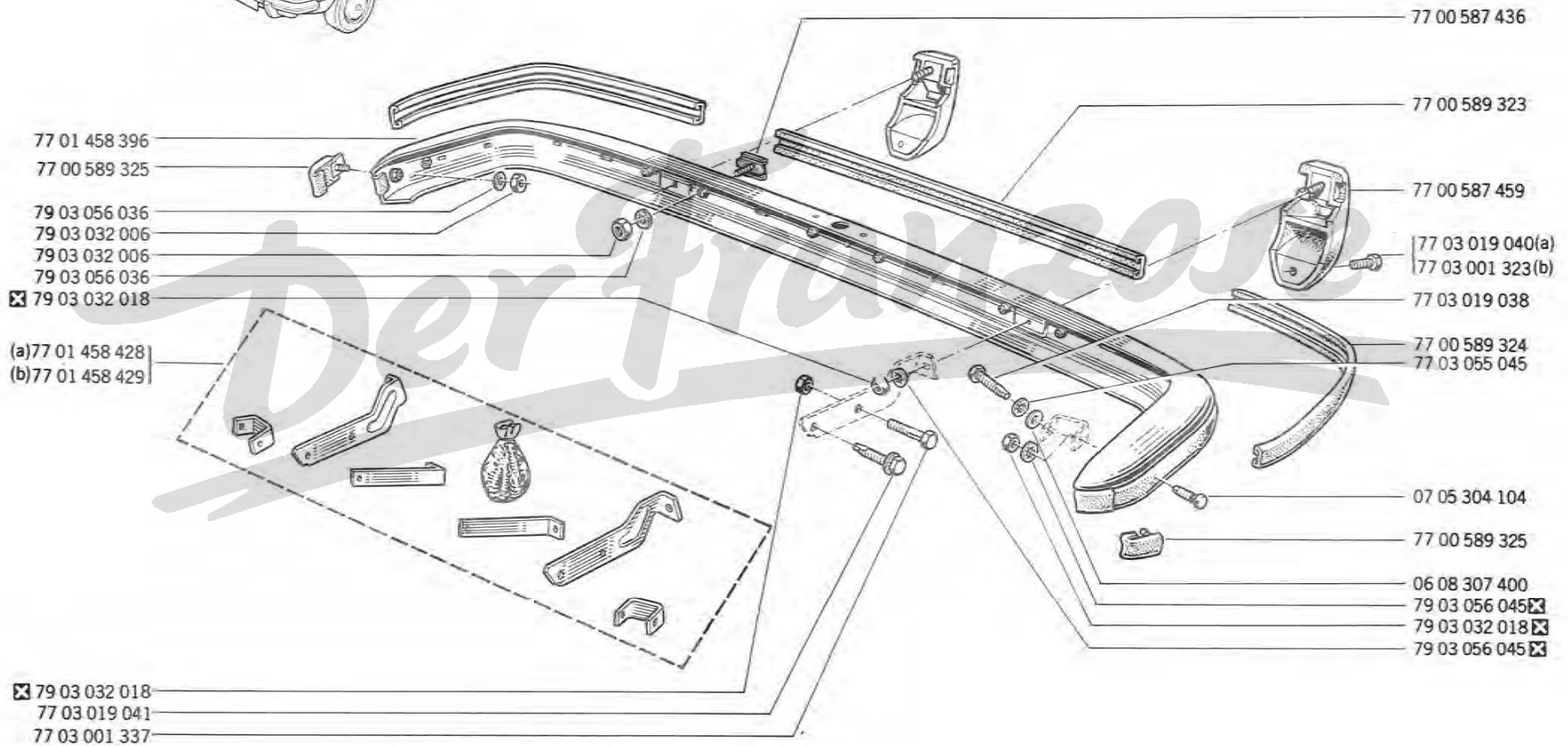
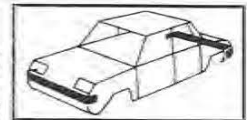

(a) R 1273 /100/600

(b) R 1273 /120

55.20

A P.R.1030

55.20

A P.R.1030

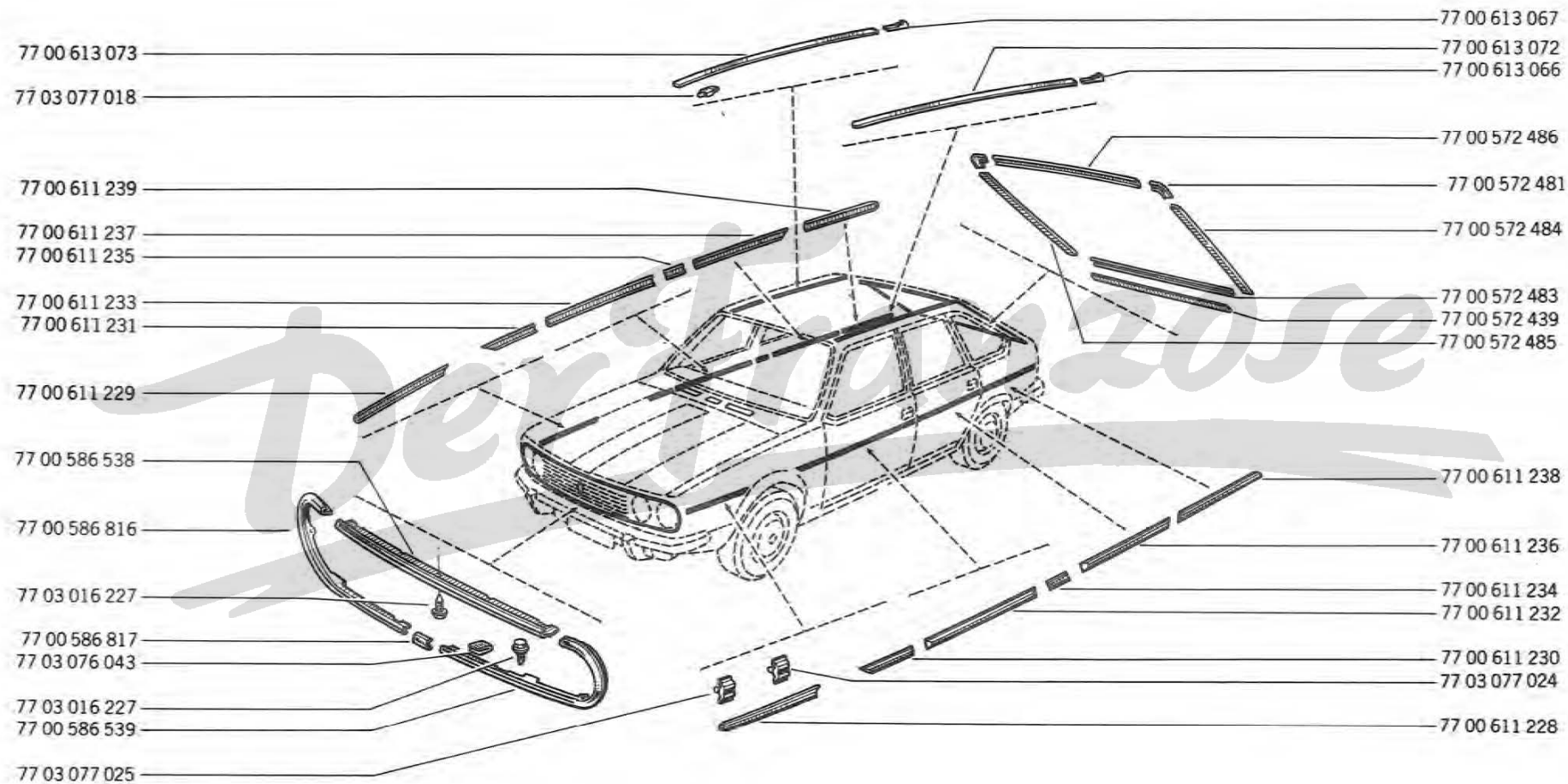
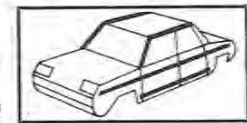

55.30

A P.R.1030



55.30

A P.R.1030

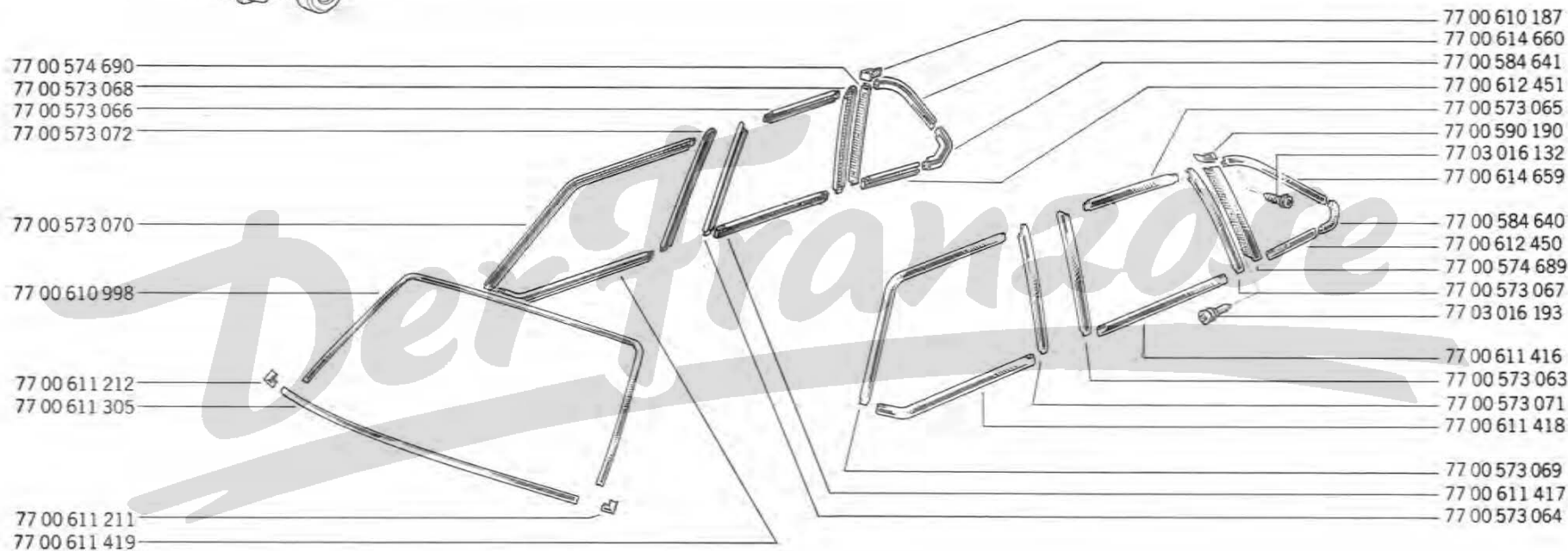

55.40
A P.R.1030

55.40
A P.R.1030

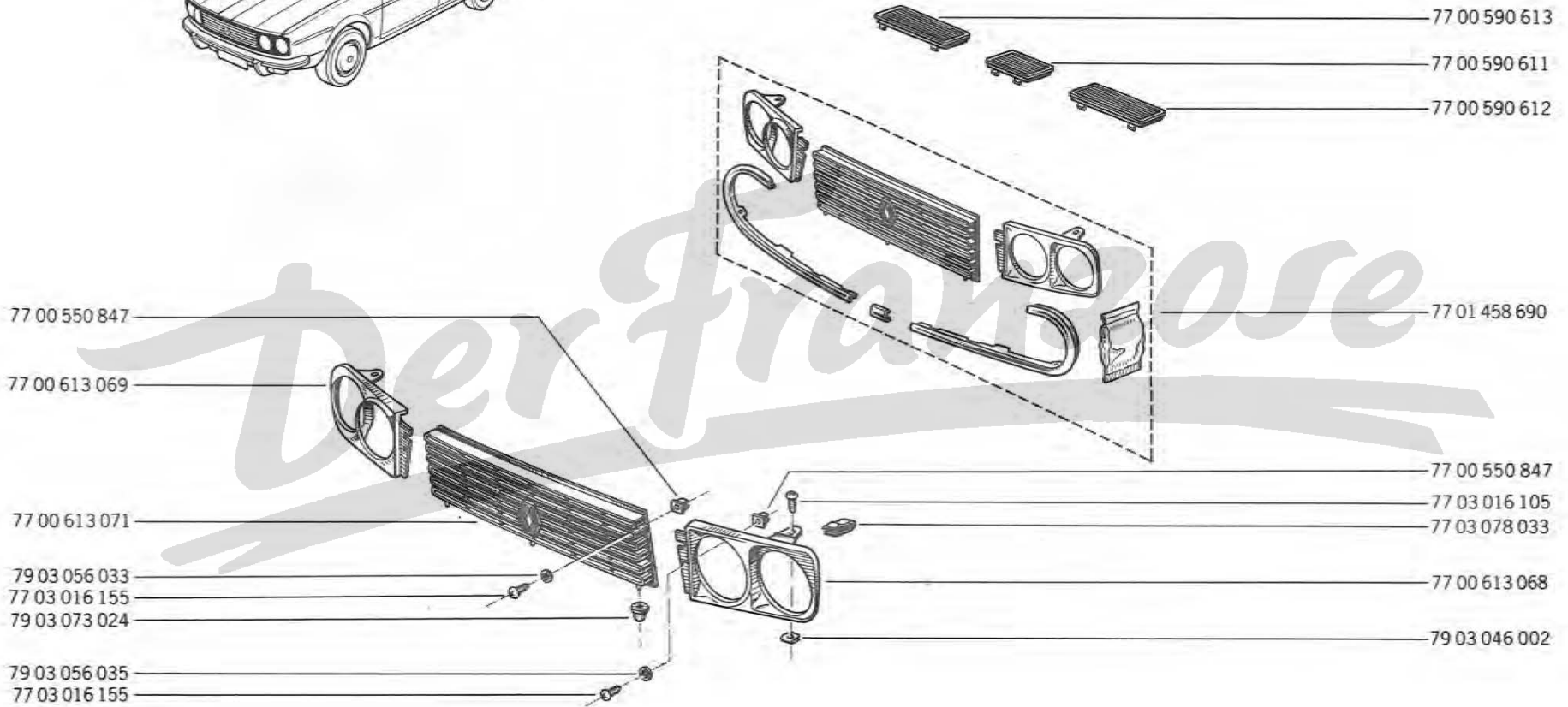
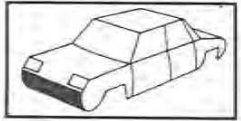

56.01

A P.R.1030

56.01

A P.R.1030



77 00 618 632



77 00 589 745



77 00 611 425

Der Franzose

77 00 612 609



77 00 612 611

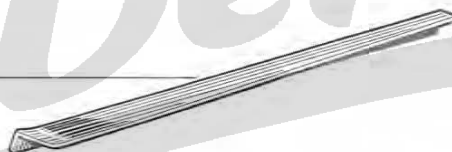

77 00 612 608

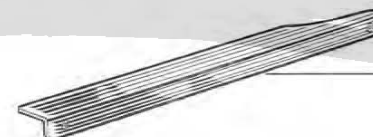

77 00 550 847

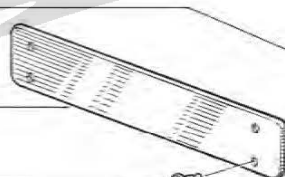

77 00 612 610

77 00 575 540

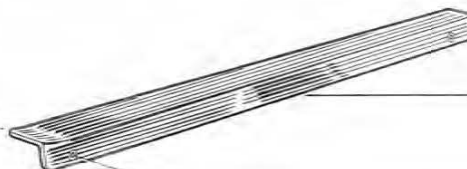

77 03 072 052



77 03 016 155



56.20
A P.R.1030

56.20
A P.R.1030



Der Franzose

77 03 005 021



77 01 018 513

77 00 611 185

77 01 010 158



56.40

A PR.1030

56.40

A PR.1030

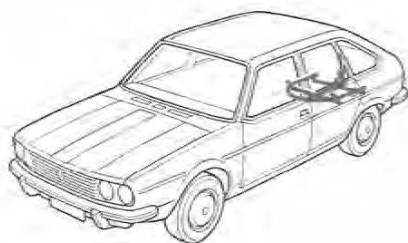
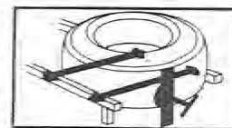

Der Franzose

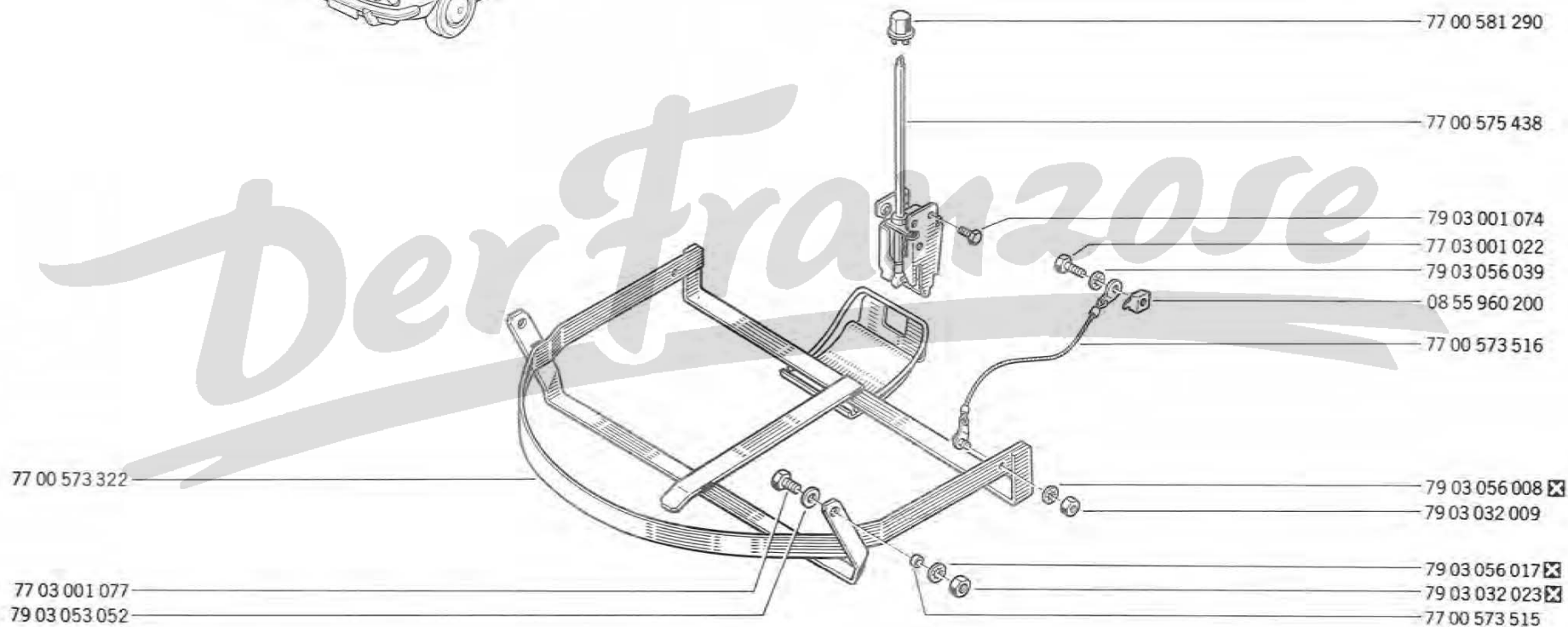

57.01

A P.R.1030



57.01

A P.R.1030

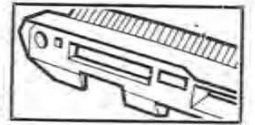

- 13 77 00 579 898
- 5 77 00 575 843
- 77 03 001 447
- 77 00 573 879
- 77 03 088 001

- 13 77 00 615 375
- 8 77 00 615 381
- 6 77 00 615 378

- 13 77 00 615 247
- 8 77 00 615 261
- 6 77 00 615 254

77 03 072 104

- 79 03 032 018 ☒
- 79 03 056 039
- 77 03 001 320
- 79 03 056 030
- 77 00 573 880
- 08 54 766 500
- 77 00 611 071

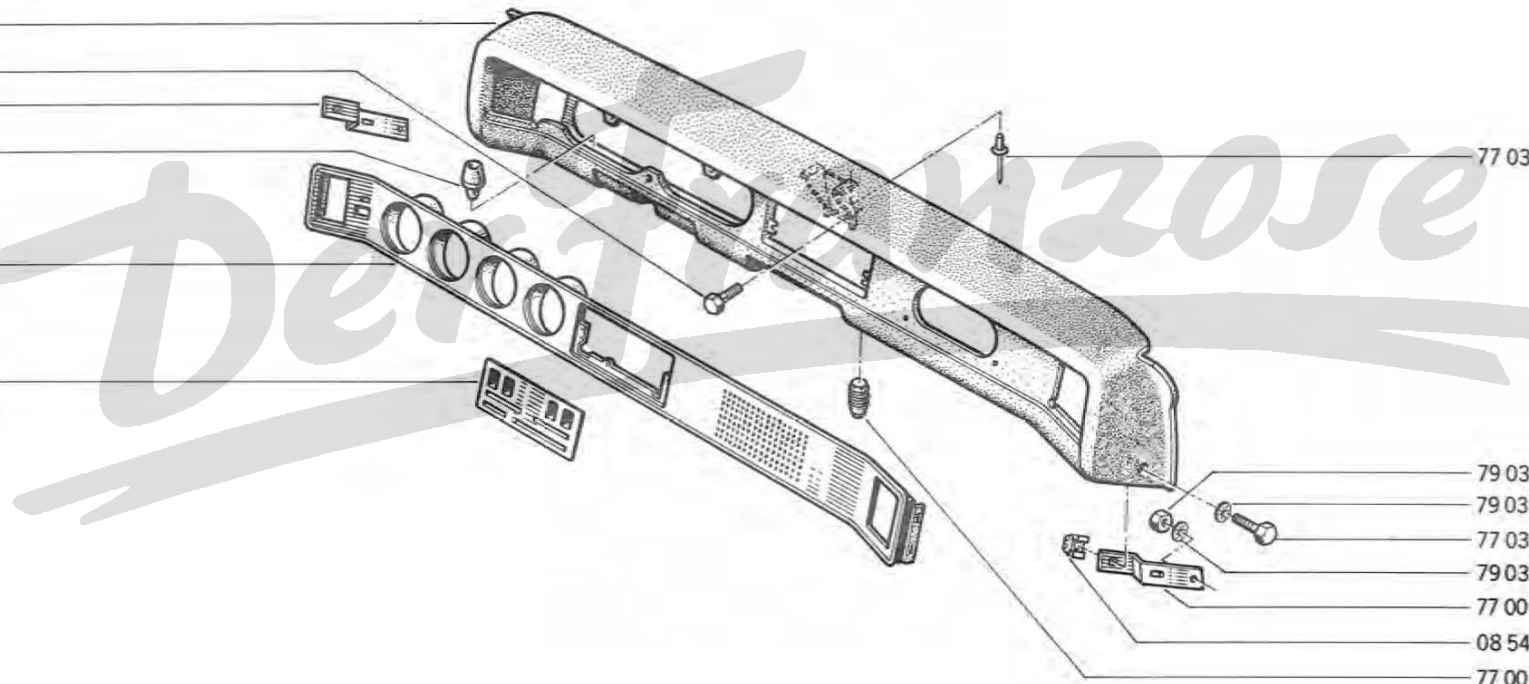

57.10

A P.R.1030



57.10

A P.R.1030

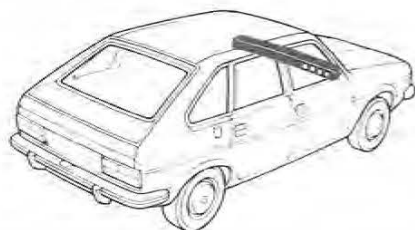
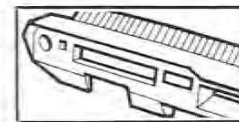

77 00 611 071

77 00 573 879

77 03 001 447

13 77 00 615 461

8 77 00 615 467

6 77 00 615 464

13 77 00 615 247

8 77 00 615 261

6 77 00 615 254

77 03 072 104

77 00 575 844 5

77 00 579 899 13

79 03 032 018 X

79 03 056 039

77 03 001 320

79 03 056 030

77 00 573 880

08 54 766 500

77 03 088 001

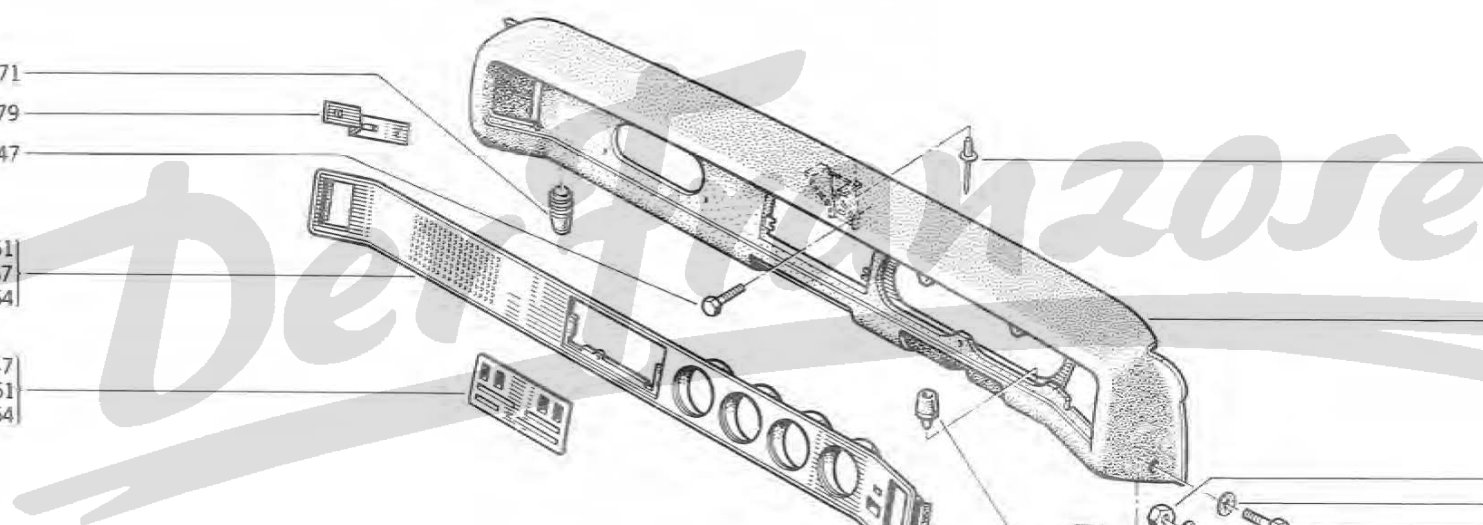

57.30
A P.R.1030

57.30
A P.R.1030

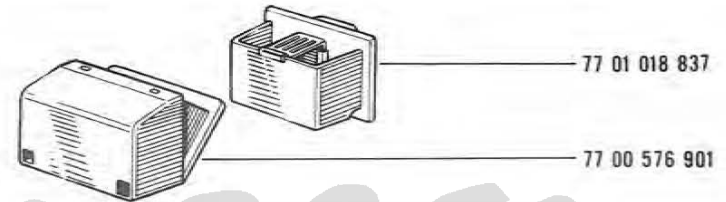
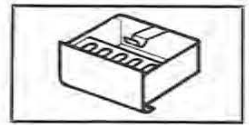

77 01 018 690

77 03 007 007

79 03 056 035

77 00 576 900

Der *Franzose*

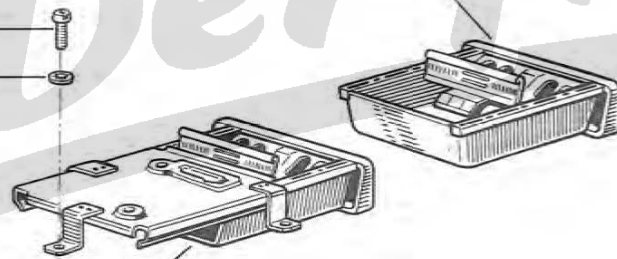

58.01

A P.R.1030

58.01

A P.R.1030

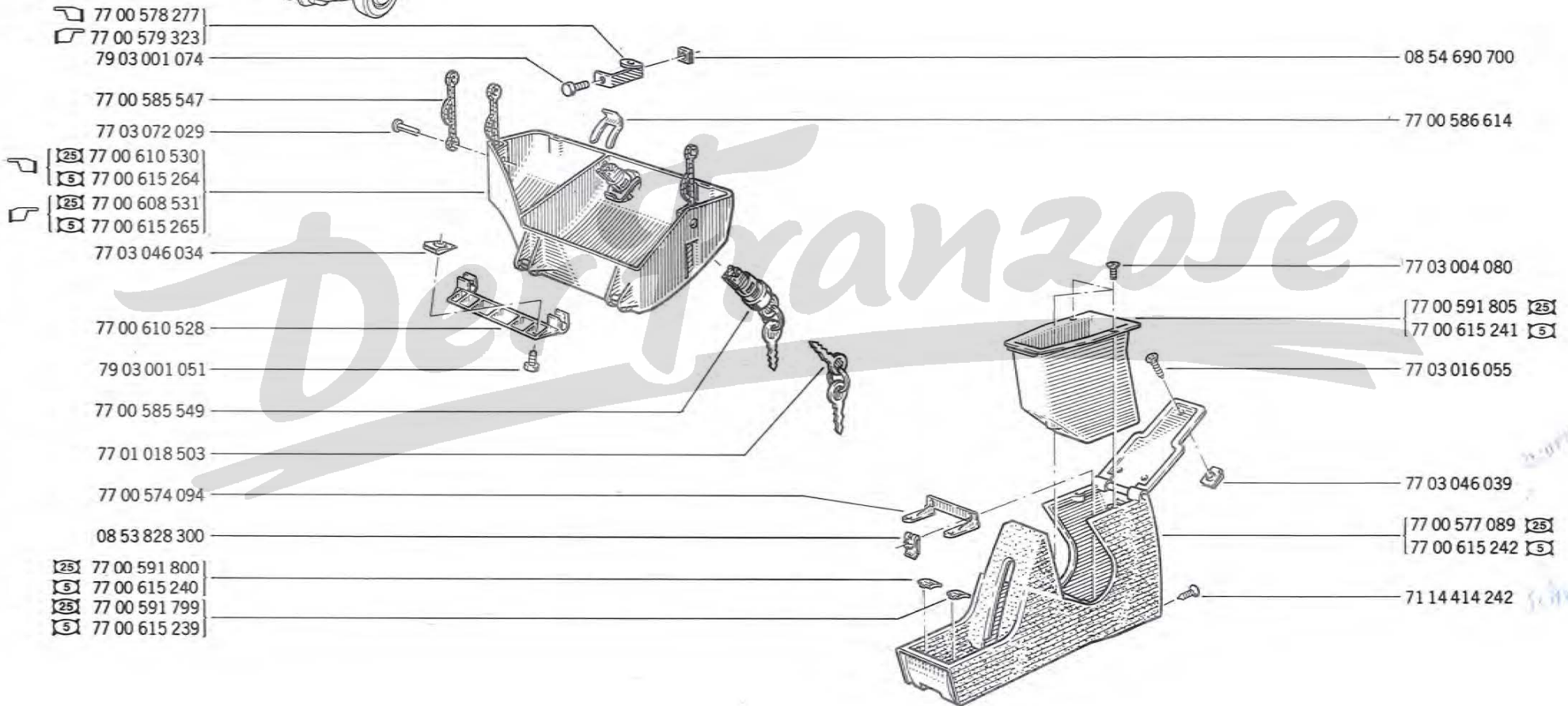
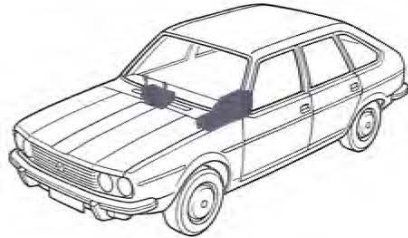
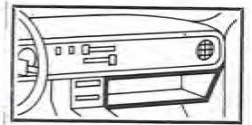

Deutsche Franzose

3-0777

5-0001

58.20
A P.R.1030

58.20
A P.R.1030



77 00 612 666

77 00 590 926

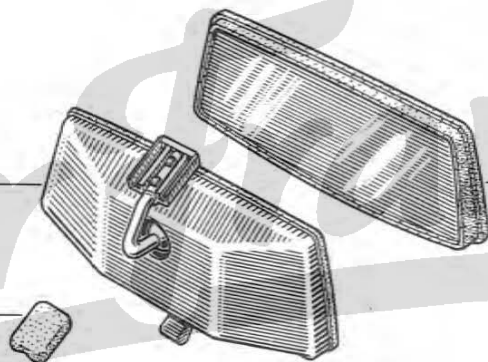

77 01 018 774

Der... n20se



58.30

A P.R.1030



58.30

A P.R.1030

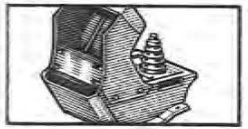

☑ (25) 77 00 576 591
(5) 77 00 615 370

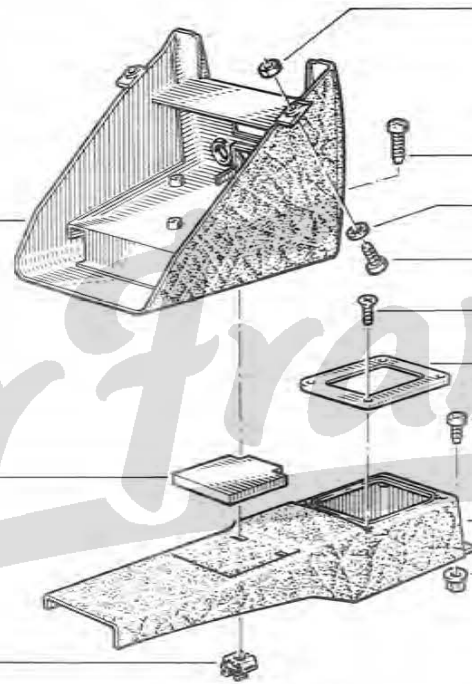

07 06 032 602 ☑

77 03 007 109

79 03 056 027

77 03 007 105 ☑

77 03 005 037 ⚡

77 00 574 136 ⚡

77 03 007 117

77 00 574 649

77 00 576 841 (25) ⚡
77 00 615 396 (5) ⚡

79 03 044 014

08 52 497 800

77 00 576 590 (25) ⚡
77 00 615 369 (5) ⚡

Derfranzose

58.40

A P.R.1030

58.40

A P.R.1030

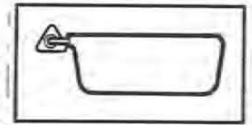

- 6 77 00 614 586
- 8 77 00 614 589
- 15 77 00 614 592
- 16 77 00 614 595

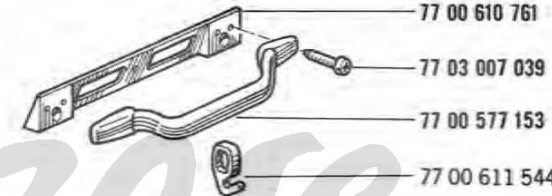
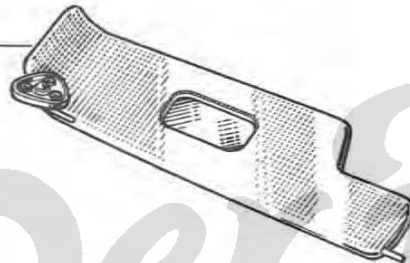

Der Franzose

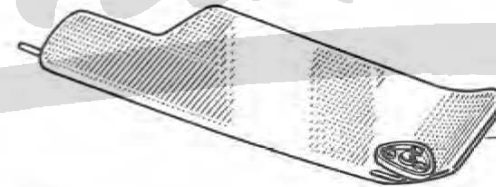

- 77 00 614 587 6
- 77 00 614 590 8
- 77 00 614 593 15
- 77 00 614 596 16

- 77 00 614 585 6
- 77 00 614 588 8
- 77 00 614 591 15
- 77 00 614 594 16

- 08 53 523 300
- 6 77 00 611 611
- 8 77 00 611 610
- 15 77 00 611 609
- 16 77 00 611 608
- 77 03 016 067

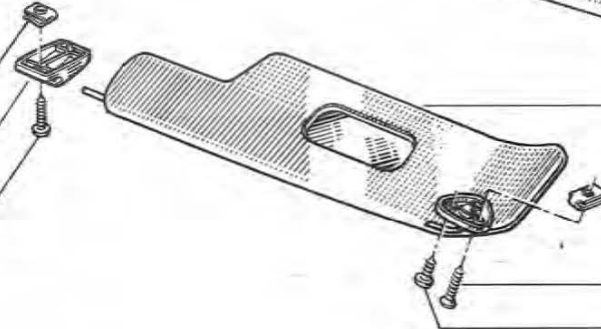

08 53 523 300

77 03 016 067

77 03 016 017

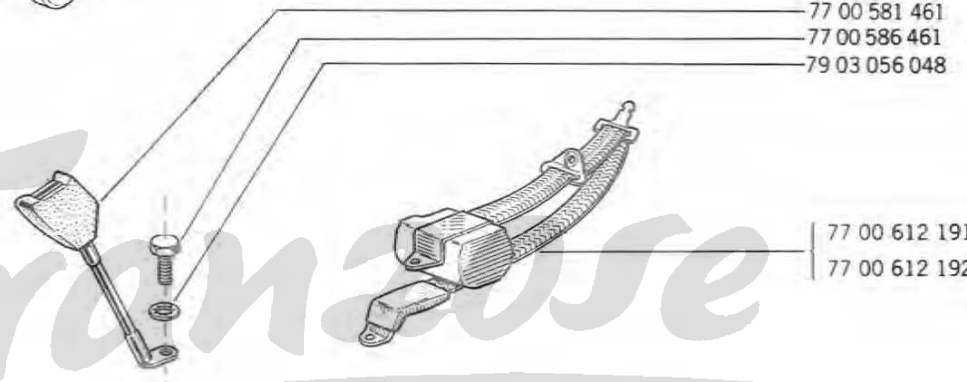
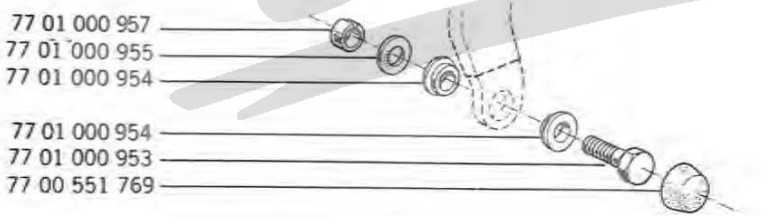
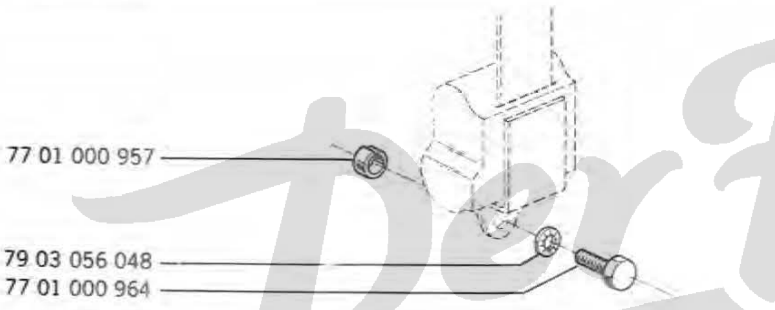
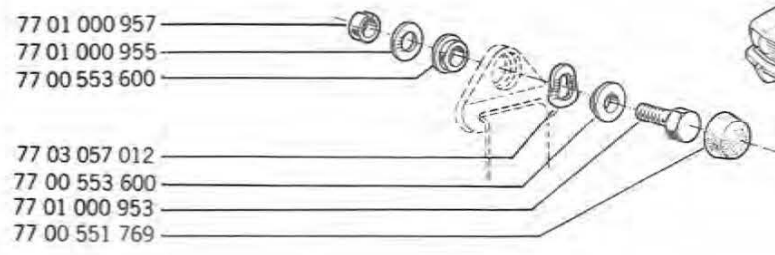
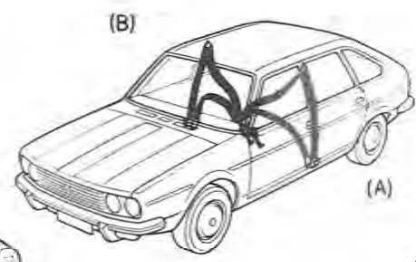

Der Franzone

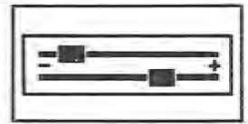

- 13 77 00 573 129
- 5 77 00 615 205

77 03 001 712

79 03 044 014

77 00 571 332

77 00 571 330

79 03 001 037

77 00 533 030

77 03 016 029

77 00 572 851

77 03 001 684

- 13 77 00 575 066
- 5 77 00 615 203

- 77 00 565 955
- 77 00 571 369

77 00 523 786

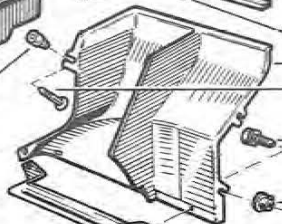
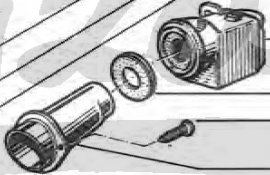
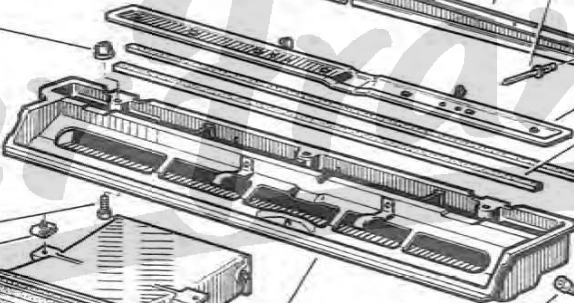
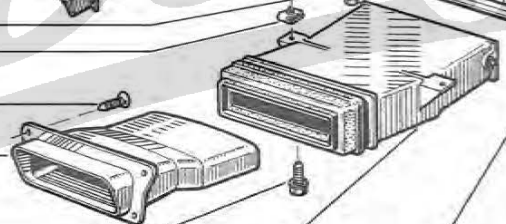
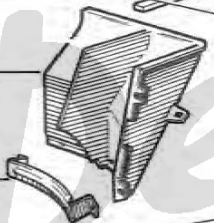
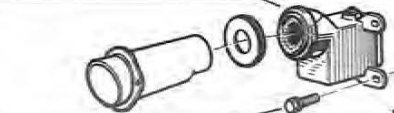

- 77 00 587 322 13
- 77 00 615 157 5

77 00 551 530

77 00 551 527

77 03 072 043

- 77 00 587 321 13
- 77 00 615 156 5

77 00 565 953

77 00 613 851

77 00 613 850

- 77 00 573 128 13
- 77 00 615 204 5

77 00 571 201

77 03 016 022

77 00 570 296

77 00 571 496

08 54 834 200

77 00 571 333

77 00 523 787

77 03 001 684

77 03 044 008

77 00 571 331

77 03 016 135

60.20

A P.R.1030

60.20

A P.R.1030

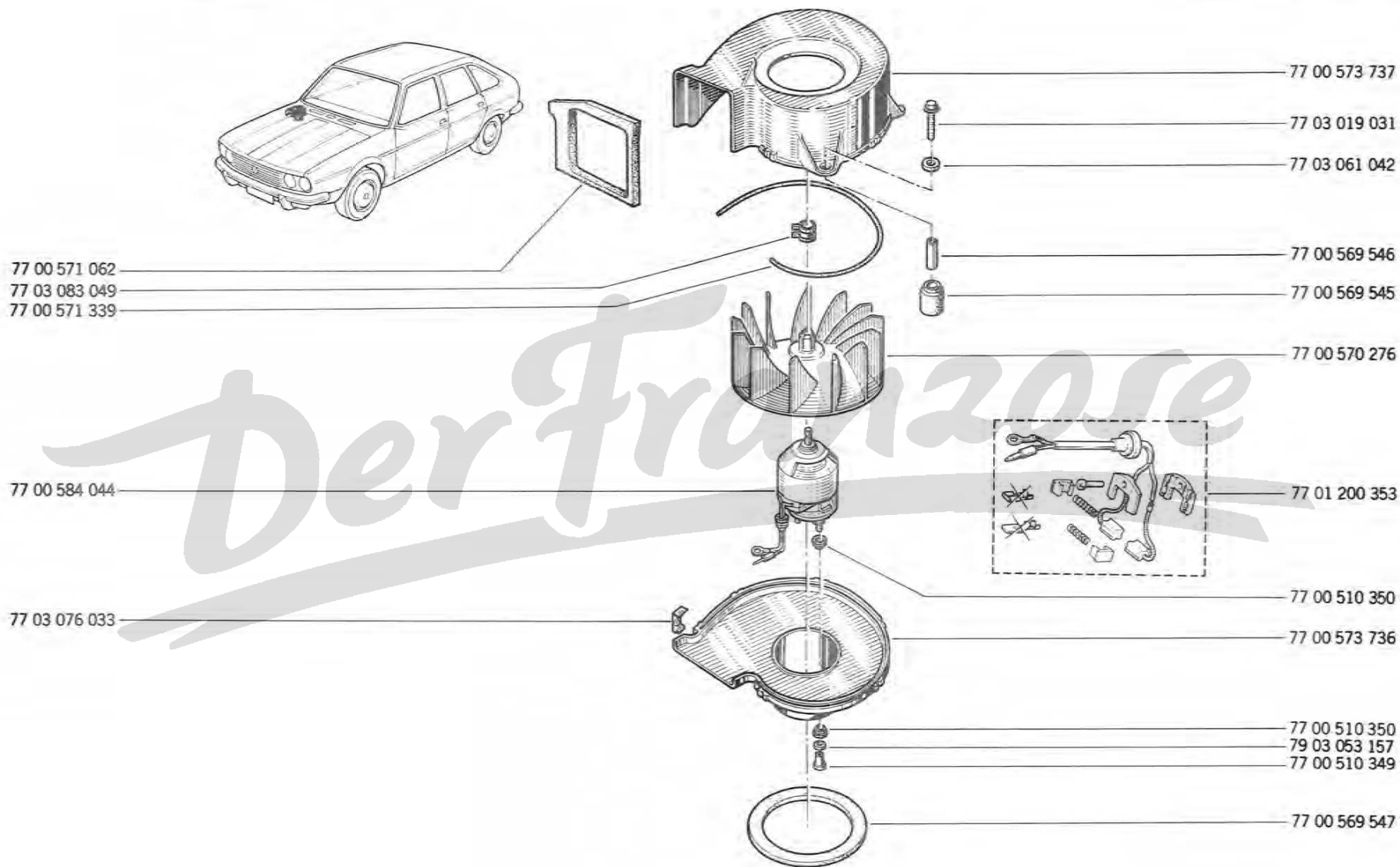

61.01
A P.R.1030

61.01
A P.R.1030

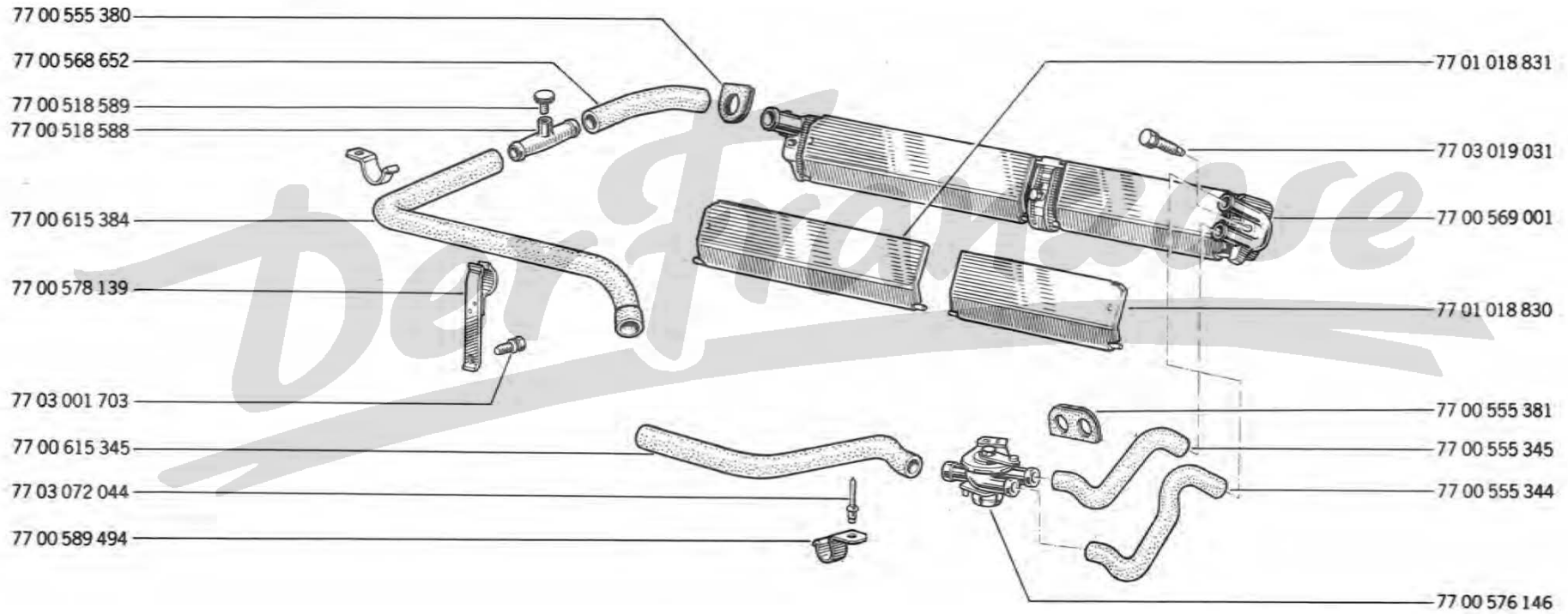
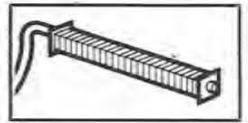

61.30

A P.R.1030

61.30

A P.R.1030

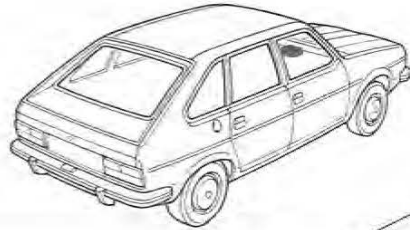
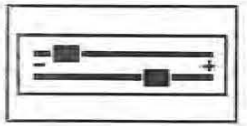

08 53 980 400

77 00 610 995

77 01 018 738

77 03 007 123

77 01 018 741

77 01 018 740

77 01 018 742

77 00 615 155

77 00 587 676

77 03 001 001

79 03 053 118

77 01 018 739

77 01 018 737

77 01 018 739

77 00 610 996

77 00 610 997

77 01 018 735

77 03 072 043

77 00 615 206

77 00 611 457

77 01 018 736

77 00 610 994

Dexfranzose



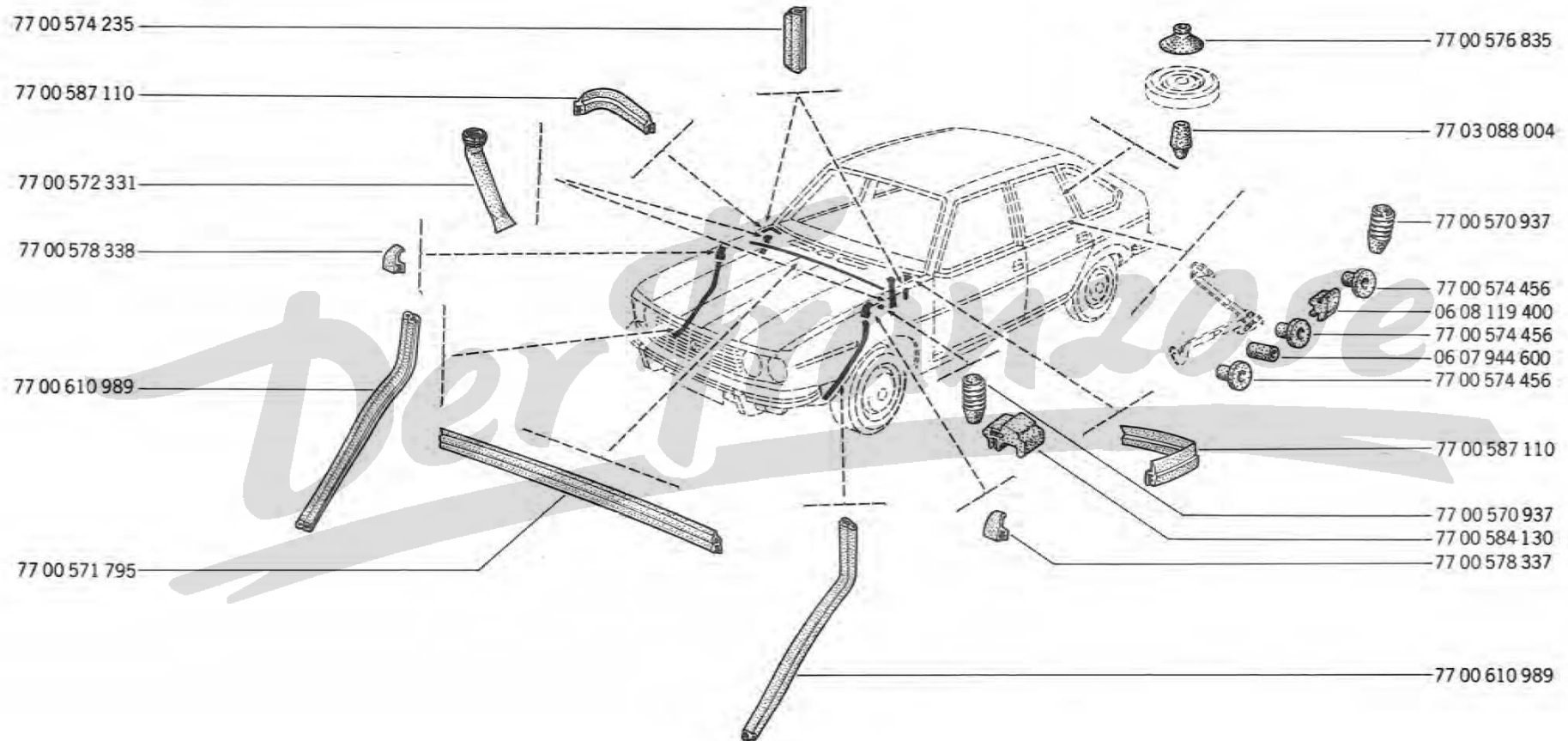
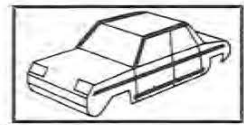

65.01

A P.R.1030

65.01

A P.R.1030

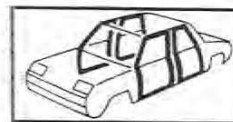

- 5 77 00 588 220
- 6 77 00 588 226
- 8 77 00 588 229
- 15 77 00 588 232
- 16 77 00 588 223

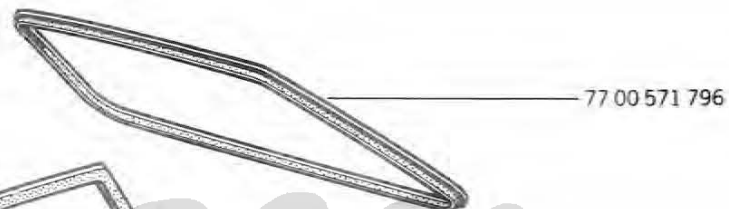

77 00 571 796

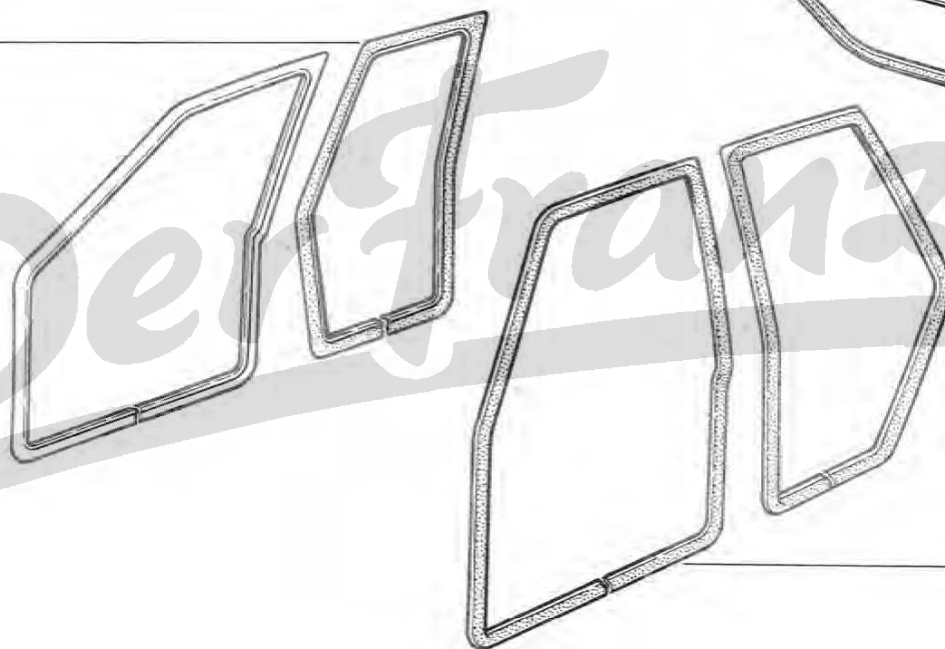

- 77 00 588 219 5
- 77 00 588 225 6
- 77 00 588 228 8
- 77 00 588 231 15
- 77 00 588 222 16

- 77 00 588 218 5
- 77 00 588 224 6
- 77 00 588 227 8
- 77 00 588 230 15
- 77 00 588 221 16

Der Franzose



66.01

A P.R.1030

66.01

A P.R.1030



77 00 585 732

77 00 569 938

77 00 576 594

77 00 568 752

77 00 576 593

77 00 568 901

77 00 568 902

77 03 076 022

77 00 574 042

77 00 568 905

77 00 568 903

77 03 076 022

77 00 574 041

77 00 568 904

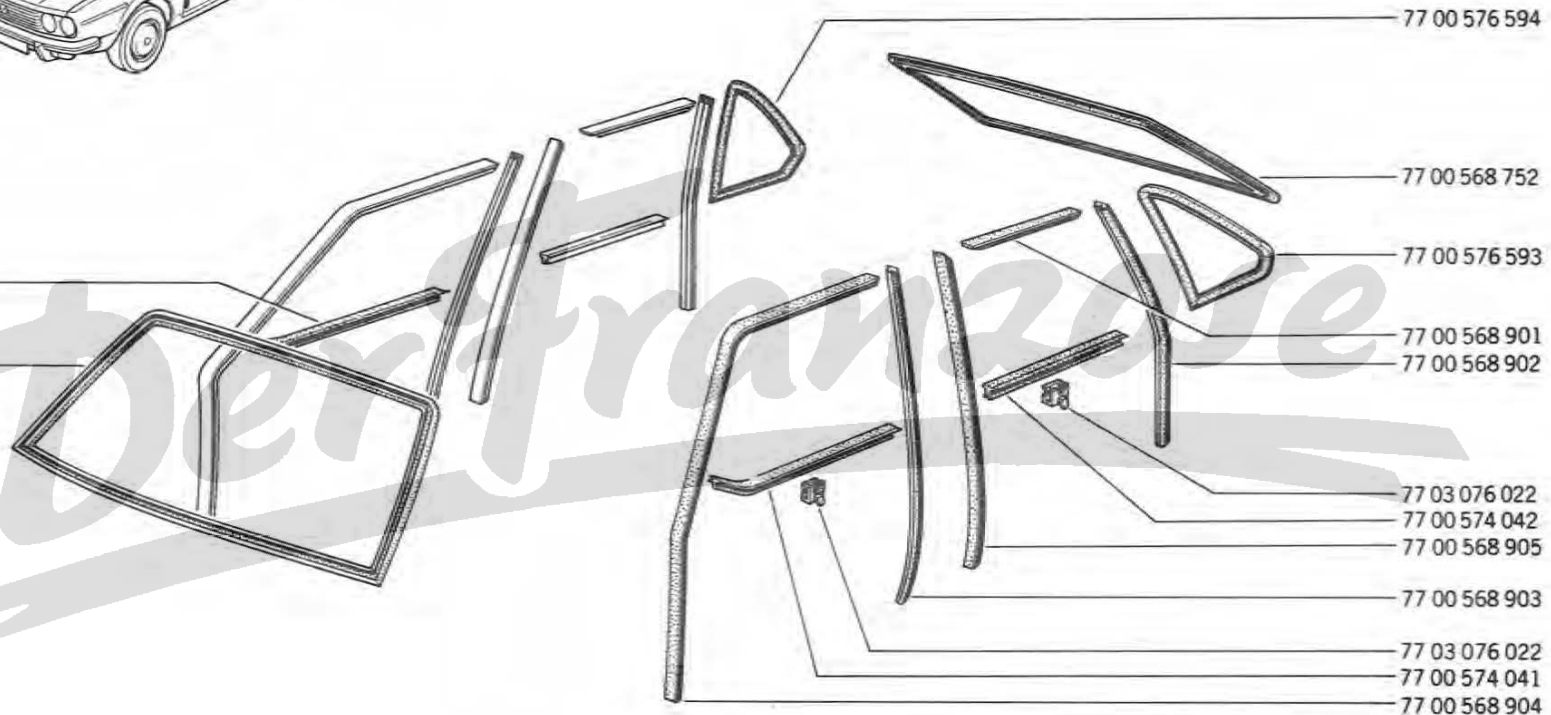





68.01

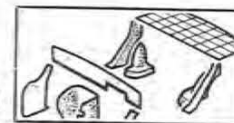

A P.R. 1030

68.01

A P.R. 1030



  77 00 611 561
 77 00 611 562

 77 00 612 052
 77 00 612 053

08 55 257 200

77 00 572 704

79 03 056 035

77 03 016 022

77 00 585 596 

77 00 586 442 

77 00 573 114 

77 00 573 115 

77 00 574 056 

77 00 580 880 

77 00 612 056 

77 00 612 057 

69.01

A P.R.1030

69.01

A P.R.1030

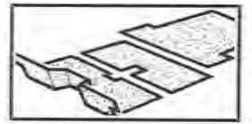

- 6 77 00 590 641
- 8 77 00 590 643
- 15 77 00 584 988
- 16 77 00 590 639

77 00 571 828

- 77 00 590 990 6
- 77 00 590 991 8
- 77 00 590 988 15
- 77 00 590 989 16

77 03 072 042
77 00 546 413

- 4+
- 6 77 00 586 727
- 8 77 00 586 728
- 15 77 00 586 725
- 16 77 00 586 726
- 6 77 00 587 278
- 8 77 00 587 279
- 15 77 00 587 276
- 16 77 00 587 277

77 00 580 379

77 00 580 379

77 00 579 544

77 00 579 545

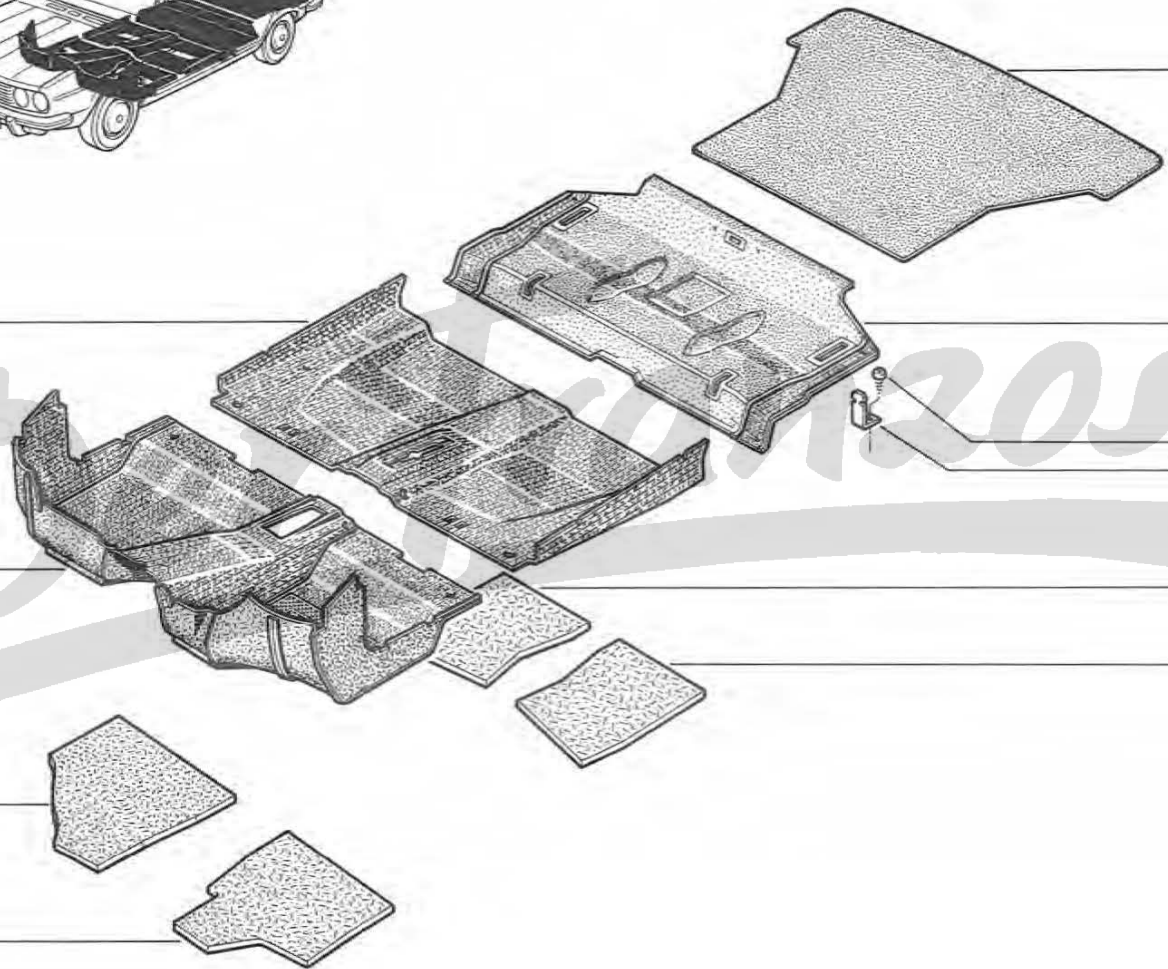

71.01

A P.R.1030



71.01

A P.R.1030

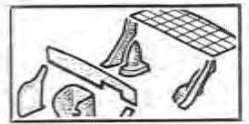

- 77 00 591 495 6
- 77 00 591 497 8
- 77 00 586 214 15
- 77 00 591 493 16

- 77 03 016 123
- 77 00 587 305
- 77 03 016 051

77 00 584 190

77 00 587 306

- 77 00 591 494 6
- 77 00 591 496 8
- 77 00 586 213 15
- 77 00 591 492 16

77 01 458 399

- 77 00 591 489 6
- 77 00 591 491 8
- 77 00 584 341 15
- 77 00 591 487 16

77 01 458 398

- 77 00 591 482 6
- 77 00 591 484 8
- 77 00 584 332 15
- 77 00 591 480 16

77 03 016 078

- 6 77 00 591 488
- 8 77 00 591 490
- 15 77 00 584 340
- 16 77 00 591 486

77 03 016 186

- 6 77 00 591 483
- 8 77 00 591 485
- 15 77 00 584 333
- 16 77 00 591 481

- 6 77 00 590 785
- 8 77 00 590 783
- 15 77 00 590 781
- 16 77 00 590 787

77 00 550 847

- 6 77 00 591 766
- 8 77 00 591 764
- 15 77 00 591 762
- 16 77 00 591 768

08 57 533 400

- 5 77 00 611 983
- 25 77 00 590 306
- 4 77 03 078 030

- 6 77 00 591 765
- 8 77 00 591 763
- 15 77 00 591 761
- 16 77 00 591 767

- 6 77 00 590 784
- 8 77 00 590 782
- 15 77 00 590 780
- 16 77 00 590 786

77 03 016 078



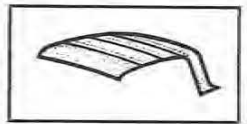

- 77 00 589 089
- 77 00 576 008
- 77 00 576 008
- 77 00 576 007
- 77 00 575 974
- 77 00 576 006
- 77 00 575 975
- 77 00 575 975
- 77 00 586 154

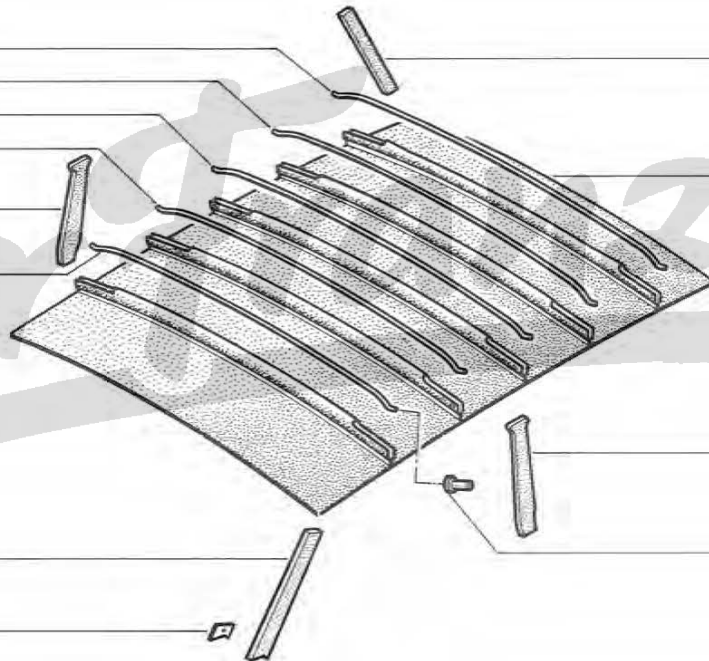

- 77 00 581 993
- 77 00 611 548
- 77 00 611 638
- 77 00 611 639
- 77 00 611 540
- 77 00 581 993
- 77 00 575 974
- 77 00 516 031



72.01

A P.R.1030

72.01

A P.R.1030

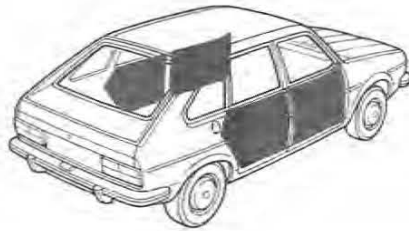

- 6 77 00 610 342
- 8 77 00 610 344
- 15 77 00 610 338
- 16 77 00 610 340

77 00 579 850

- 6 77 00 610 161
- 8 77 00 610 163
- 15 77 00 610 157
- 16 77 00 610 159

- 6 77 00 613 982
- 8 77 00 613 984
- 15 77 00 613 978
- 16 77 00 613 980

77 00 580 831

- 6 77 00 610 160
- 8 77 00 610 162
- 15 77 00 610 156
- 16 77 00 610 158

77 00 579 851

77 00 579 849

- 79 03 053 025

77 03 007 039

- 6 77 00 613 983
- 8 77 00 613 985
- 15 77 00 613 979
- 16 77 00 613 981

77 03 007 095

79 03 056 040

77 03 044 008

77 03 007 039

- 77 00 613 992 6

- 77 00 613 994 8

- 77 00 613 988 15

- 77 00 613 990 16

79 03 053 025 X

- 77 00 613 993 6

- 77 00 613 995 8

- 77 00 613 989 15

- 77 00 613 991 16

77 00 580 831

77 03 044 008

77 03 044 014

77 03 074 022

77 03 077 031

- 77 00 610 341 6

- 77 00 610 343 8

- 77 00 610 337 15

- 77 00 610 339 16

77 00 580 077

77 00 580 078

79 03 056 040

77 03 007 095

77 03 044 014

74.01

A P.R.1030

74.01

A P.R.1030



- 6 77 00 611 484
- 8 77 00 611 486
- 15 77 00 582 067
- 16 77 00 611 482

- 6 77 00 611 478
- 8 77 00 611 479
- 15 77 00 582 068
- 16 77 00 611 477

77 00 573 052

- 8 (A) 77 01 458 516
- (B) 77 01 458 517
- (C) 77 01 458 518
- (D) 77 01 458 515
- (E) 77 01 458 660
- 7 (F) 77 01 458 662
- (G) 77 01 458 661

- 77 00 611 475 6
- 77 00 611 476 8
- 77 00 582 065 15
- 77 00 611 474 18

- 77 00 611 483 6
- 77 00 611 485 8
- 77 00 582 066 15
- 77 00 611 481 16

77 00 610 911

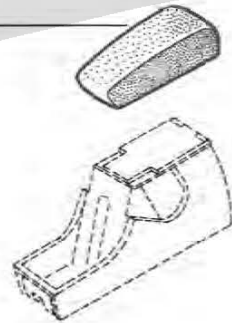

(A)	(B)	(C)	(D)	(E)	(F)	(G)
64	65	66	67	74	75	76
PR 100						

75.01

A P.R.1030

75.01

A P.R.1030

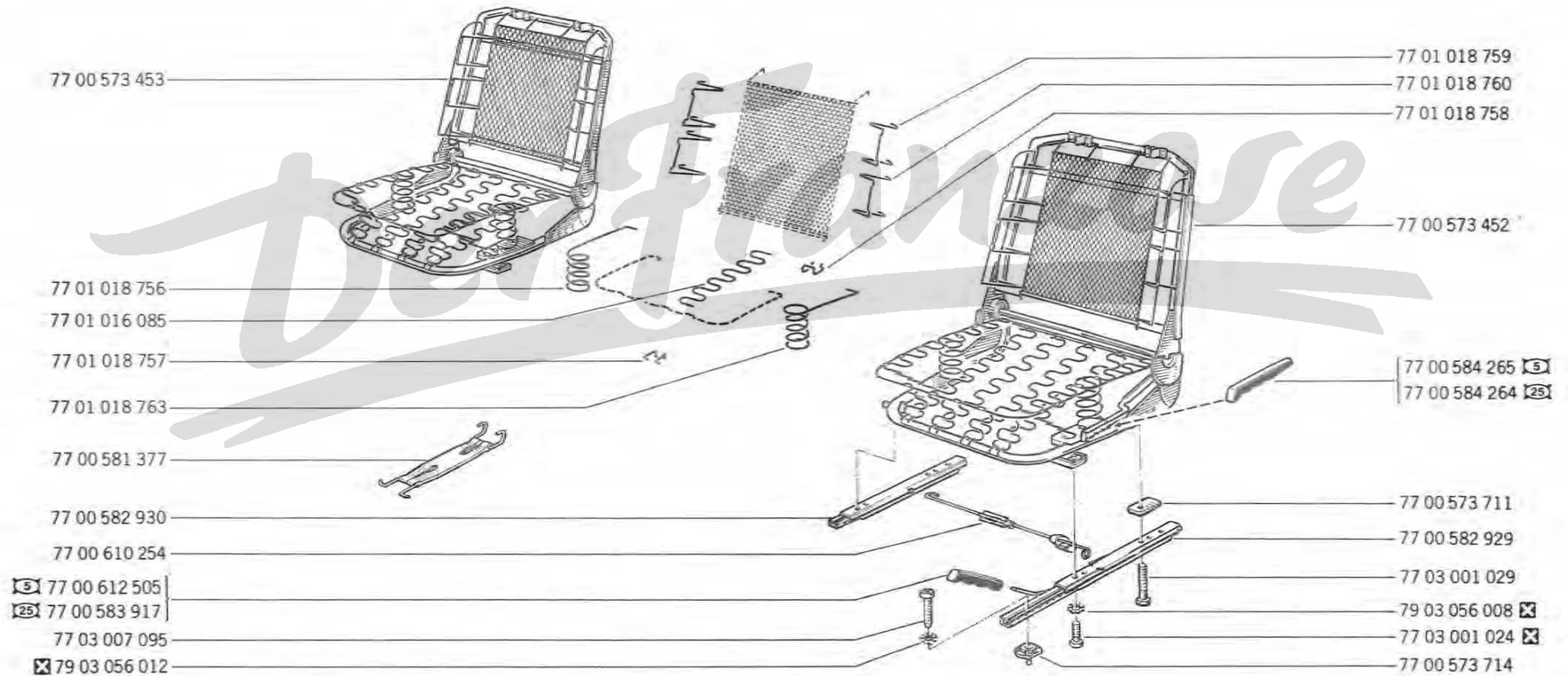
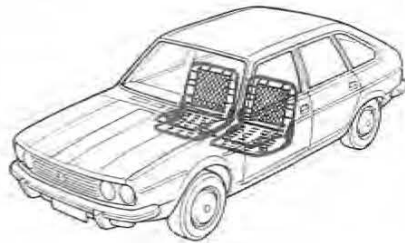

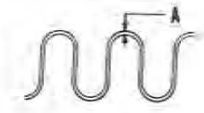
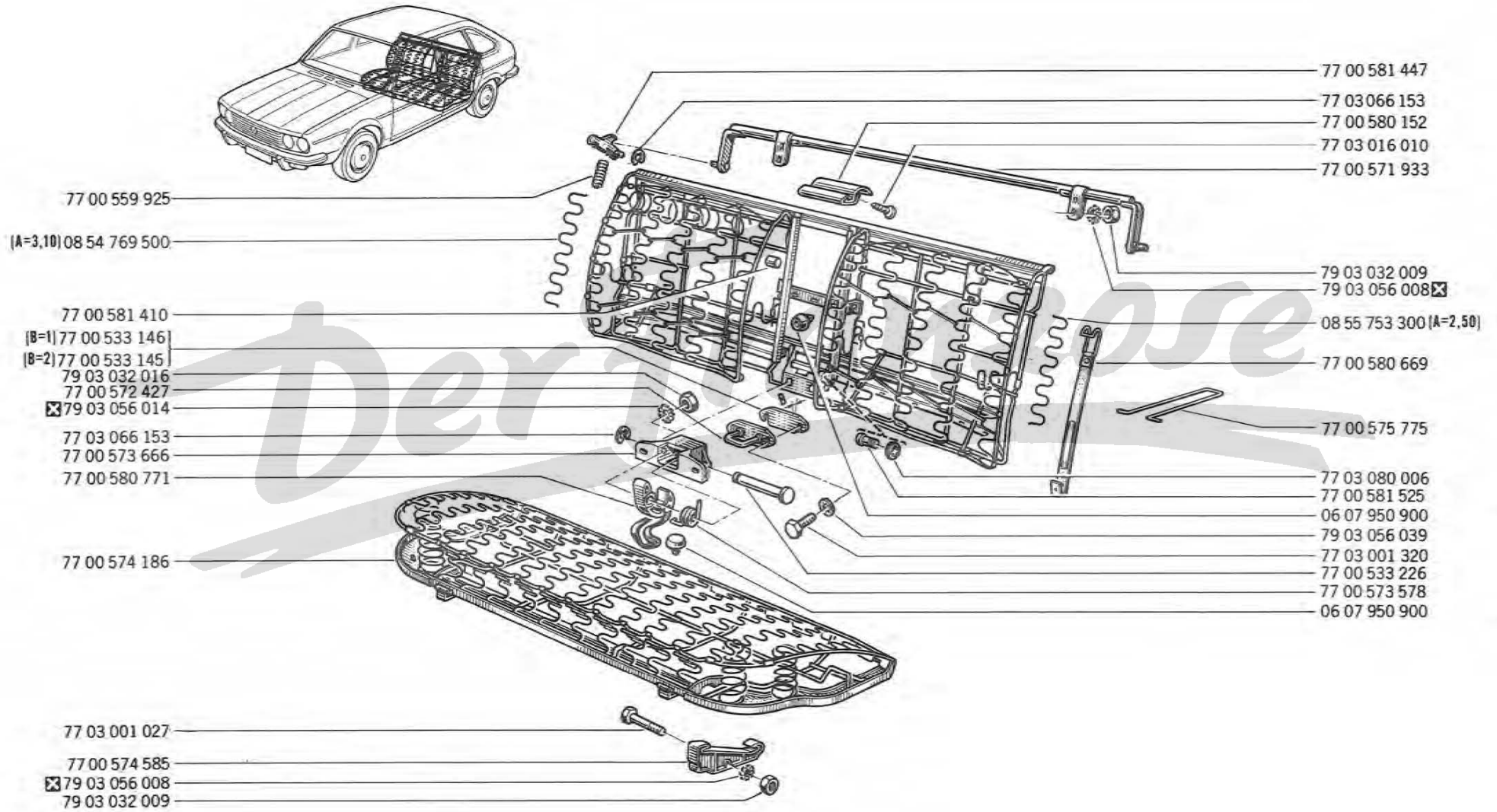

77.01

A P.R.1030

77.01

A P.R.1030

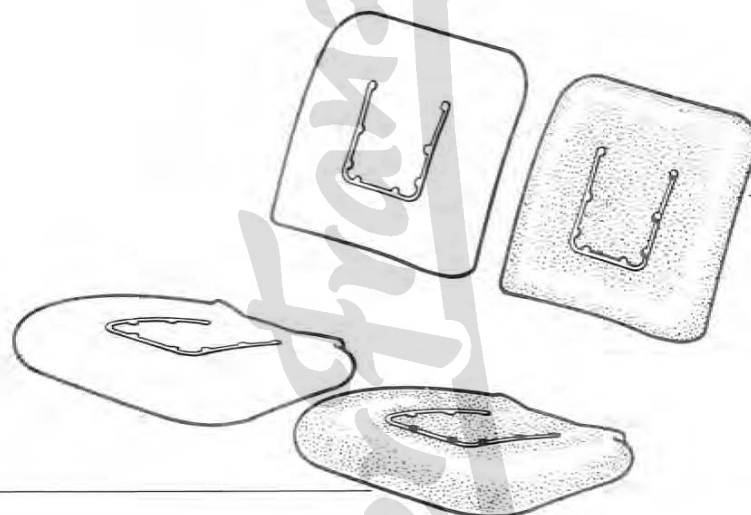
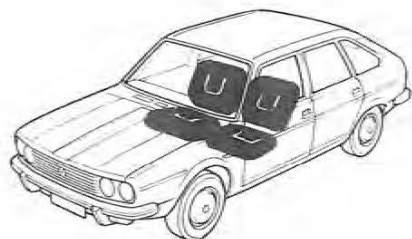
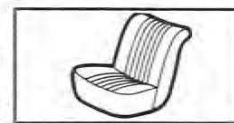

77 00 574 115

77 00 574 130

08 53 521 500



77.10

A P.R.1030

77.10

A P.R.1030

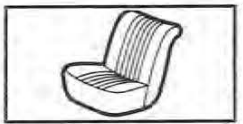

- 8 (A) 77 01 458 561
- (B) 77 01 458 562
- (C) 77 01 458 563
- (D) 77 01 458 560
- 7 (E) 77 01 458 775
- (F) 77 01 458 777
- (G) 77 01 458 776

- 6 77 00 591 520
- 8 77 00 591 524
- 15 77 00 591 512
- 16 77 00 591 516

- 3 (A) 77 01 458 576
- (B) 77 01 458 577
- (C) 77 01 458 578
- (D) 77 01 458 575
- 7 (E) 77 01 458 700
- (F) 77 01 458 702
- (G) 77 01 458 701

- 8 (A) 77 01 458 601
- (B) 77 01 458 602
- (C) 77 01 458 603
- (D) 77 01 458 600
- 7 (E) 77 01 458 715
- (F) 77 01 458 717
- (G) 77 01 458 716

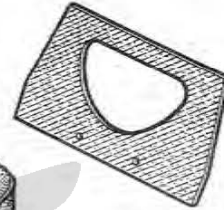

77 00 579 100

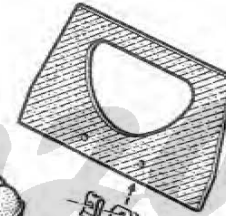

77 00 579 100

77 03 016 010

77 00 579 099

77 03 046 025

77 00 613 238

77 00 613 237

77 00 580 112

- 77 01 458 546 (A)
- 77 01 458 547 (B)
- 77 01 458 548 (C)
- 77 01 458 545 (D)
- 77 01 458 760 (E)
- 77 01 458 762 (F)
- 77 01 458 761 (G)

8

7

- 77 00 591 519 6
- 77 00 591 523 8
- 77 00 591 511 15
- 77 00 591 515 16

(A)	(B)	(C)	(D)	(E)	(F)	(G)
64	65	66	67	74	75	76
PR 100						

78.01
A P.R.1030

78.01
A P.R.1030

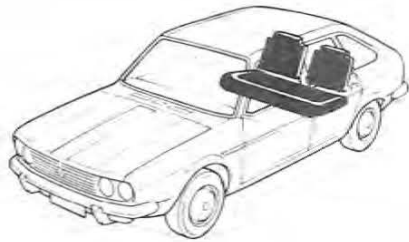
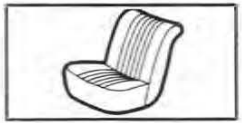

77 00 581 360

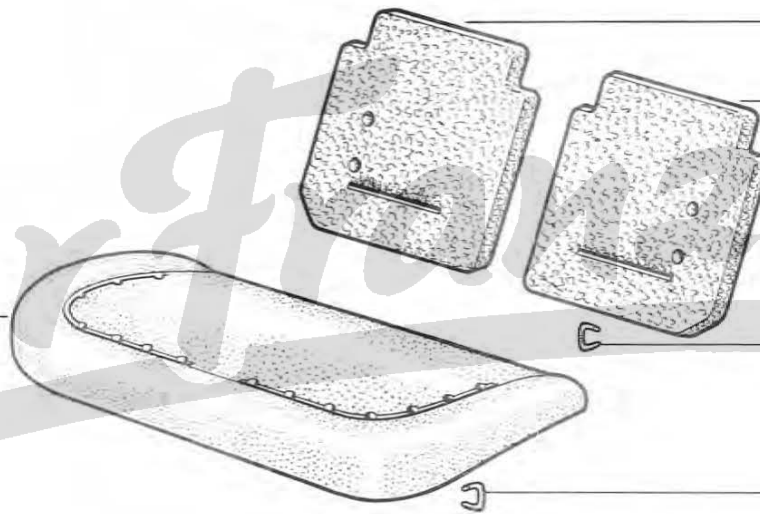

77 00 574 262

77 00 574 263

71 29 155 334

71 29 155 334



78.10

A P.R.1030

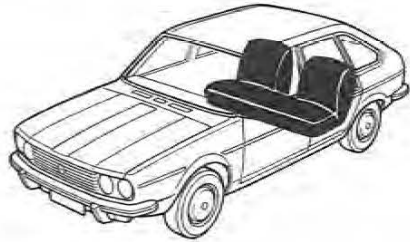

78.10

A P.R.1030

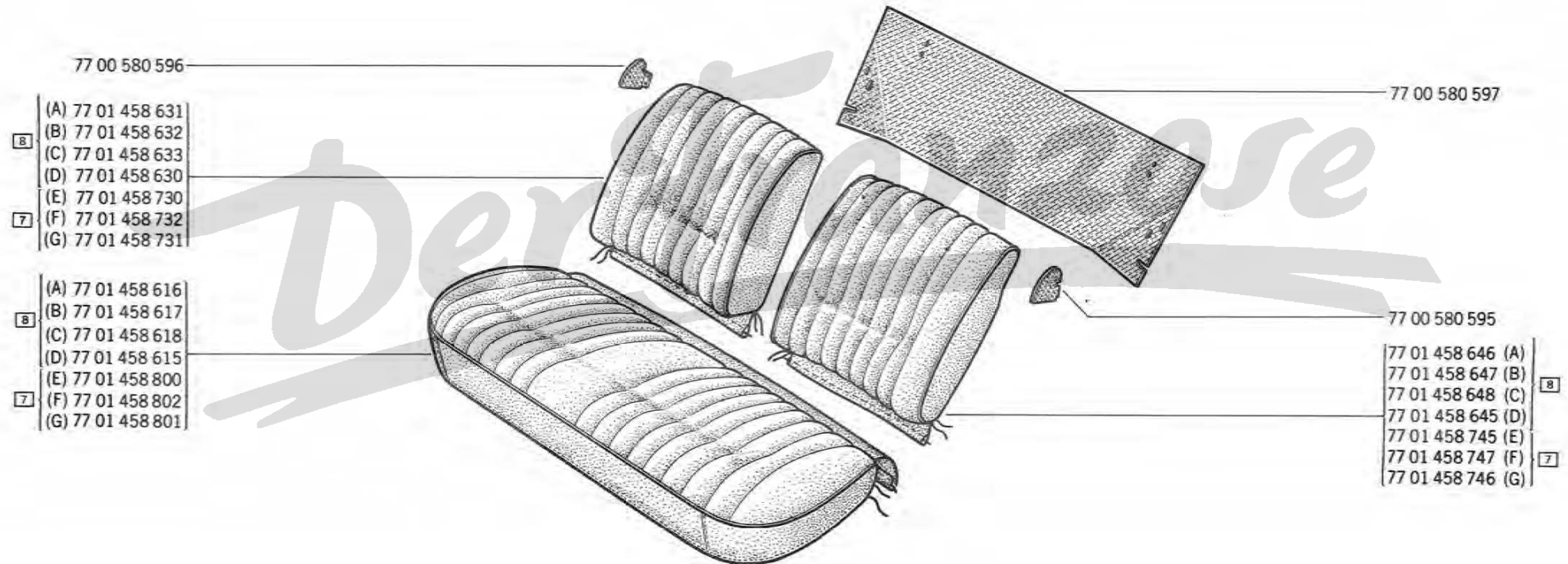

(A)	(B)	(C)	(D)	(E)	(F)	(G)
64	65	66	67	74	75	76
PR 100						

79.01

A P.R.1030

79.01

A P.R.1030

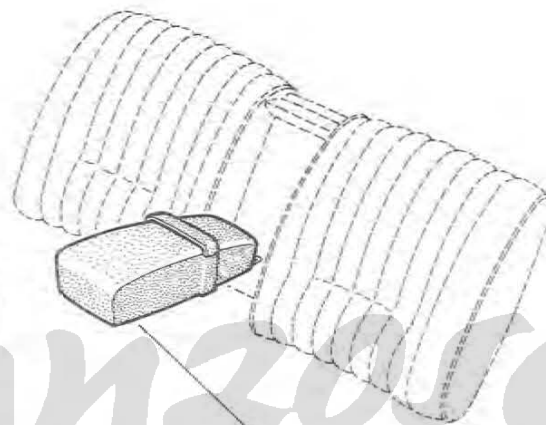
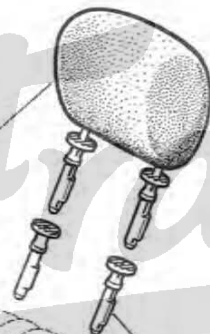
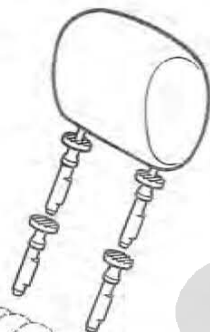
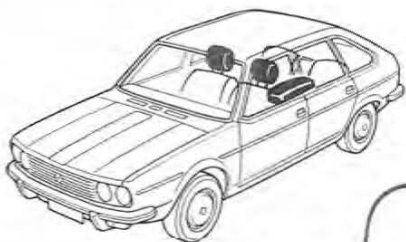

- (A) 77 00 615 926
- (B) 77 00 615 919
- (C) 77 00 615 918
- (D) 77 00 615 920
- (E) 77 00 615 921
- (F) 77 00 615 922
- (G) 77 00 615 925

- 77 01 458 531 (A)
- 77 01 458 532 (B)
- 77 01 458 533 (C)
- 77 01 458 530 (D)
- 77 01 458 675 (E)
- 77 01 458 677 (F)
- 77 01 458 676 (G)

- 77 00 612 043
- 77 00 612 044
- 77 00 612 045
- 77 00 588 249
- 77 00 612 042

(A)	(B)	(C)	(D)	(E)	(F)	(G)
64	65	66	67	74	75	76
PR 100						

80.01

A P.R.1030

80.01

A P.R.1030

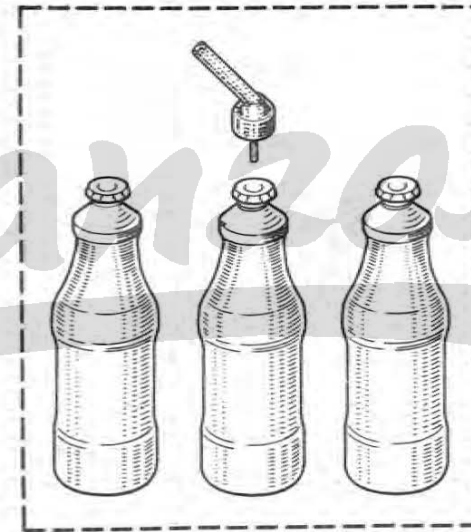
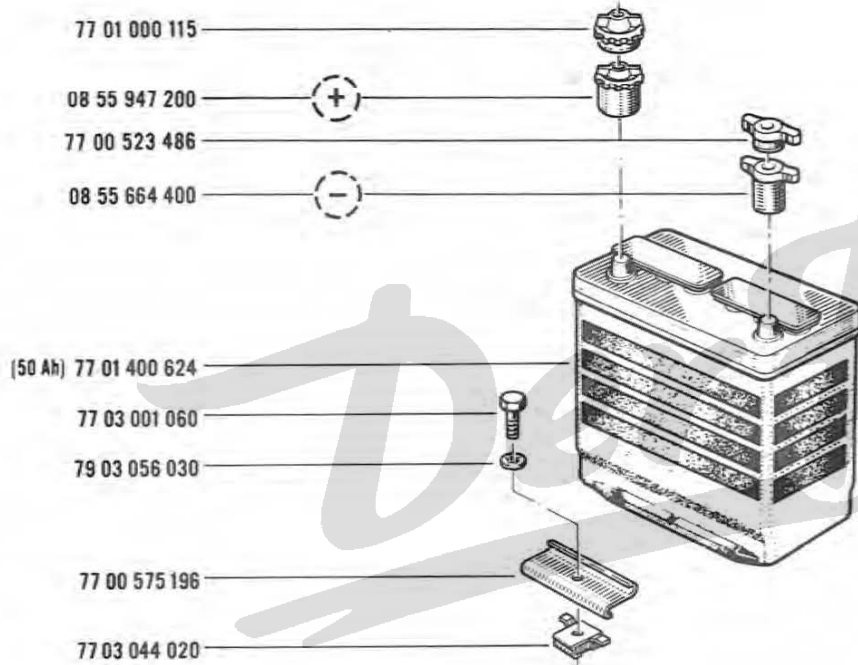
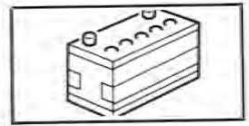

80.10

A P.R.1030

80.10

A P.R.1030

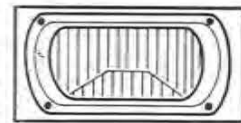

77 01 018 338

(a) 11 77 01 018 339
(c) 3 77 01 018 819
(d) 3 77 01 018 817

(a) 11 77 01 018 340
(b) 3 77 01 018 818

(a) 11 77 01 018 337
(b) 3 77 01 018 816

(a) 3 77 01 018 336
(c) 3 77 01 018 820
(d) 11 77 01 018 815

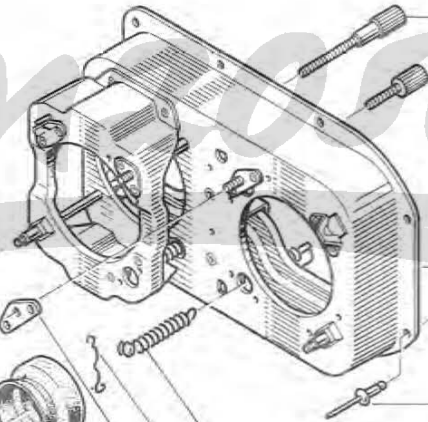
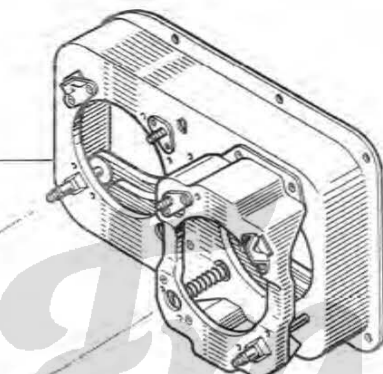

77 01 018 792

77 01 018 793

77 01 018 335

77 03 072 043

77 01 018 791

77 01 018 794

77 01 018 790

77 01 018 789

79 03 056 005 E3

79 03 032 006

79 03 001 077

(a) R1273 /100
(b) R 1273 /120/600
(c) R1273 /120
(d) R1273 /600

80.20
A P.R.1030



80.20
A P.R.1030

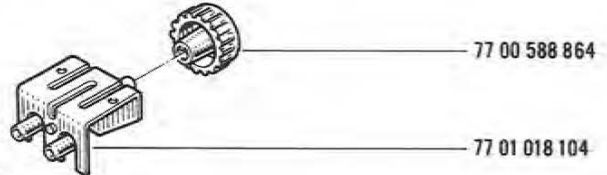
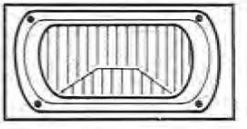

77 01 018 341

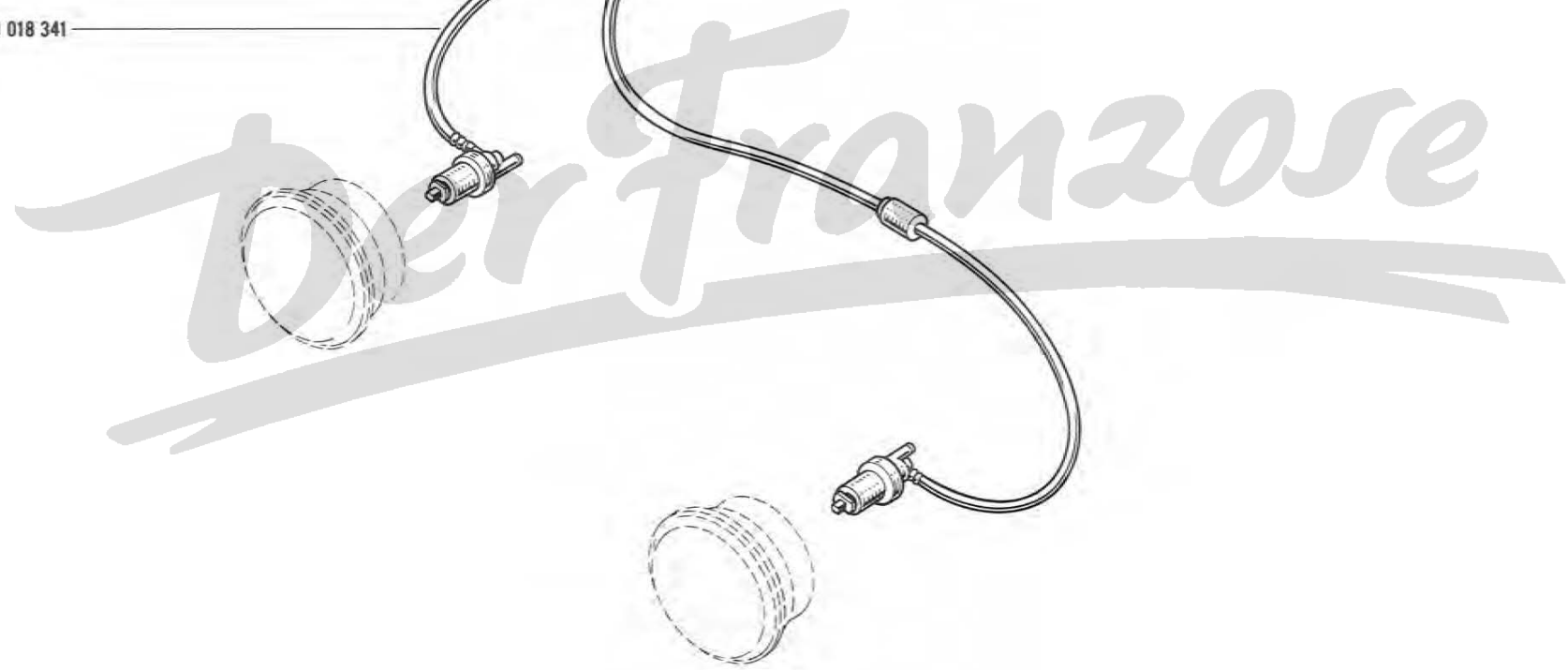

80.30
A PR 1030

80.30
A PR 1030

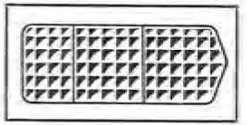

77 01 018 518

77 01 018 516

77 01 018 519

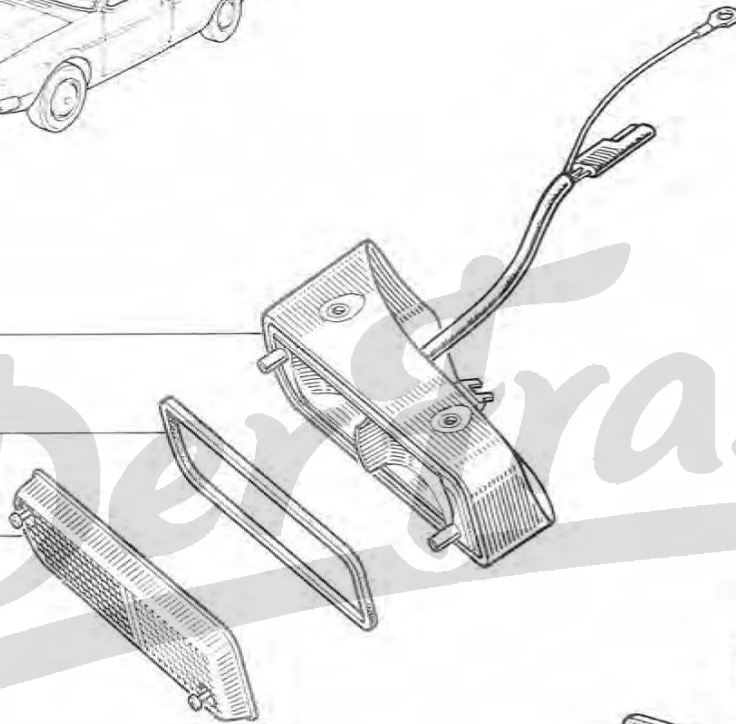

77 03 016 184

77 03 053 145

77 03 016 184

77 03 053 145

77 01 018 515

77 01 018 516

77 01 018 517

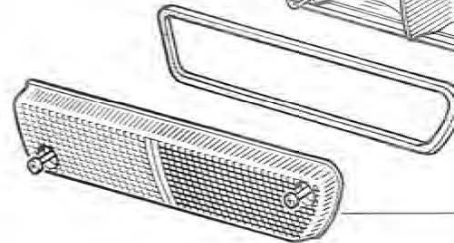

81.10

A P.R.1030

81.10

A P.R.1030

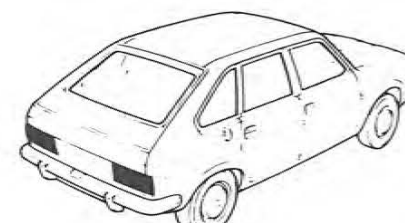
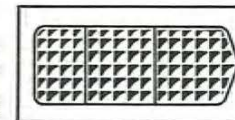

77 01 018 430

77 01 018 431

77 01 018 429

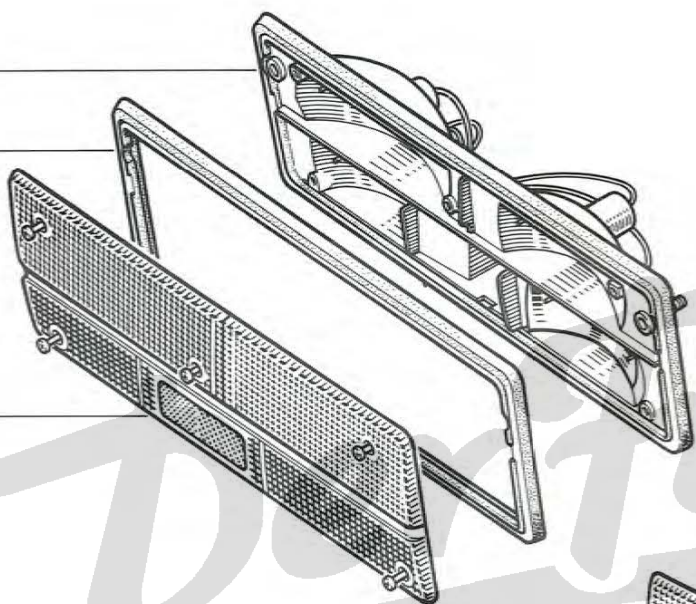

79 03 001 077

79 03 056 005 ☒

79 03 032 006



79 03 032 006

79 03 056 005 ☒

77 01 018 433

77 01 018 431

77 01 018 432

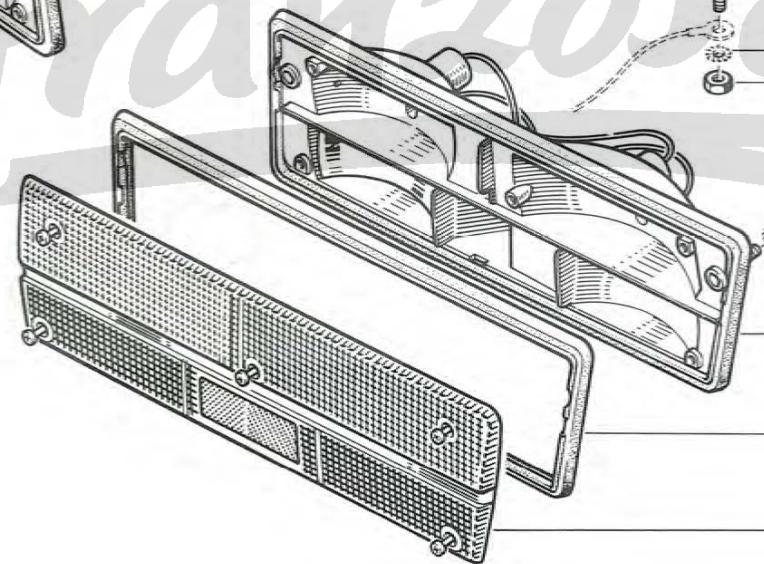

81.20

A - P.R.1030

81.20

A - P.R.1030

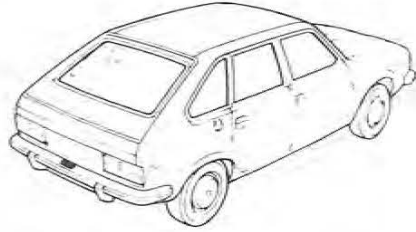
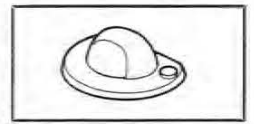

77 03 016 176



77 01 018 575



77 01 365 349

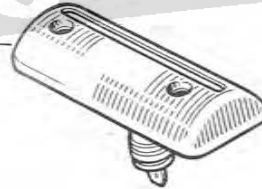

Der Franzose



81.40

A P.R.1030

81.40

A P.R.1030

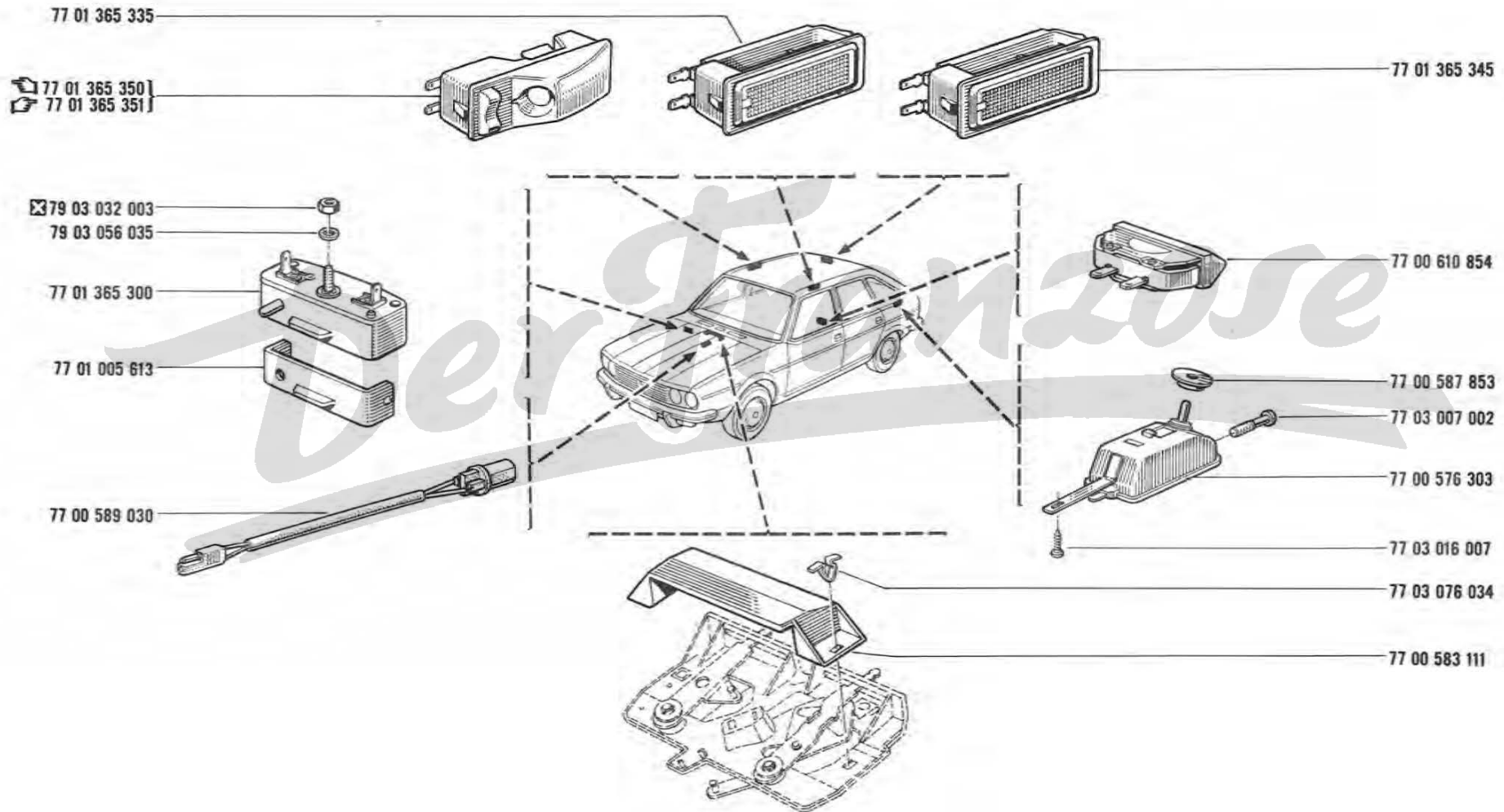
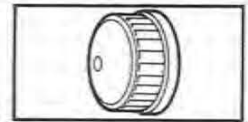

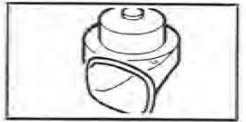

☒ 79 03 056 014

77 01 365 343

77 01 365 344

KM 4 A

KM 4 G

79 03 032 072

77 01 018 520

77 01 018 521

79 03 056 067

77 03 001 052



83.01

A P.R.1030

83.01

A P.R.1030

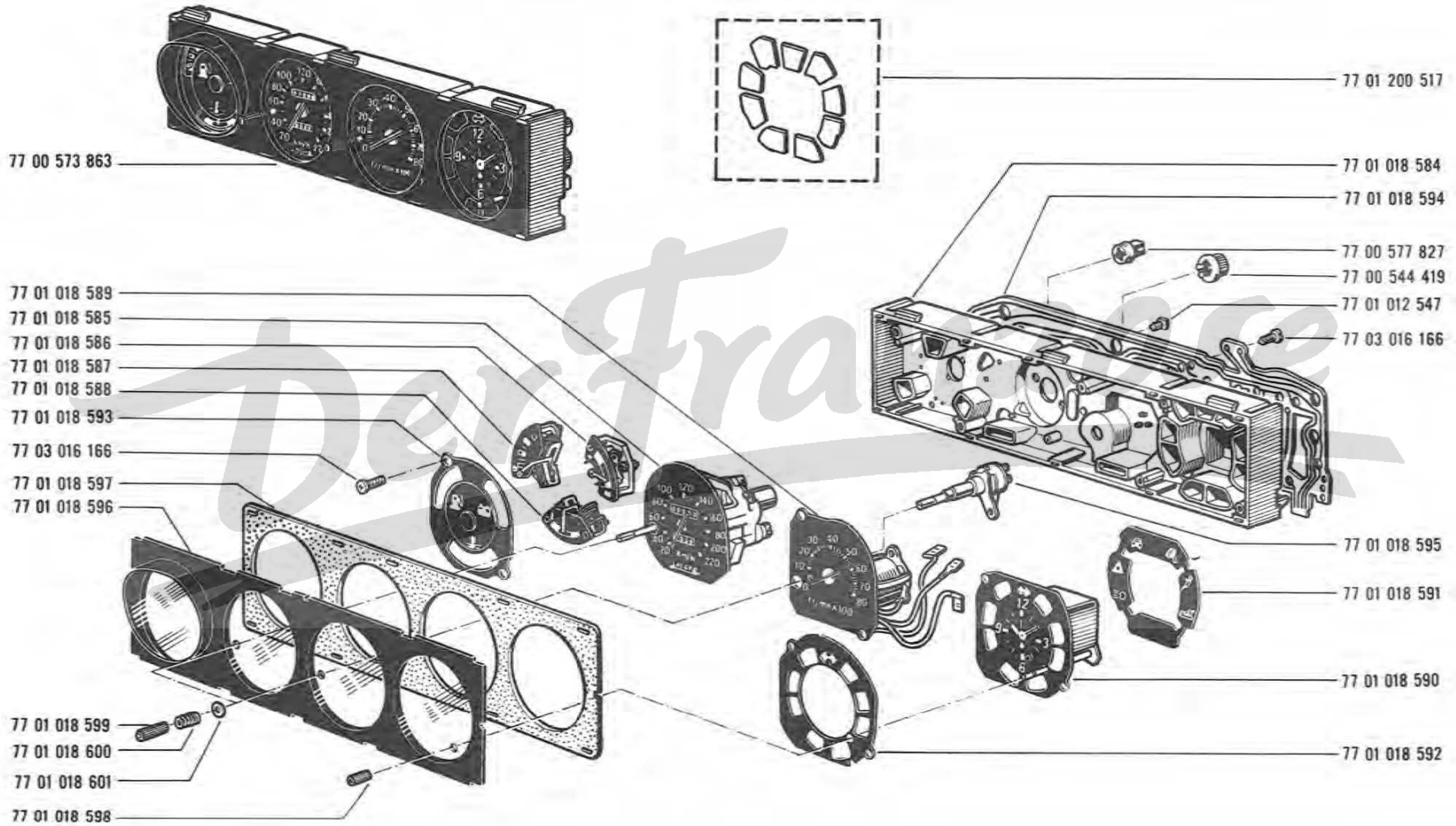
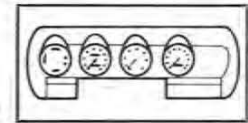

83.10

A PR.1030

83.10

A PR.1030

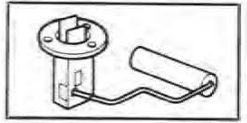

77 00 564 311

[A=1110] 77 00 572 884
[A=990] 77 00 589 461

77 00 539 258

77 00 573 286

77 00 521 180

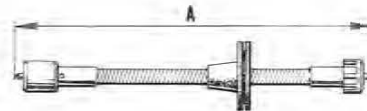

84.01

A P.R.1030

84.01

A P.R.1030



77 00 575 263
77 00 575 266

77 03 004 067
79 03 056 005
79 03 032 006
77 03 007 013
79 03 056 005

77 00 584 118
77 00 584 119

79 03 056 005
77 03 007 013

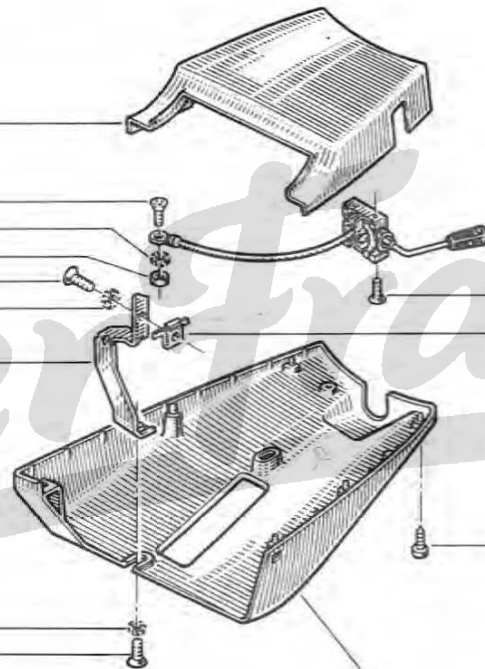

77 00 585 010

77 03 004 067

77 03 044 006

79 03 001 064

77 00 584 775

77 03 016 075

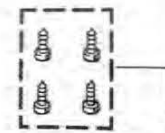

77 00 575 264
77 00 575 267



84.10

A PR.1030

84.10

A PR.1030

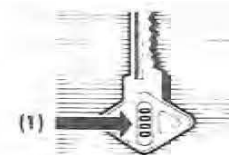
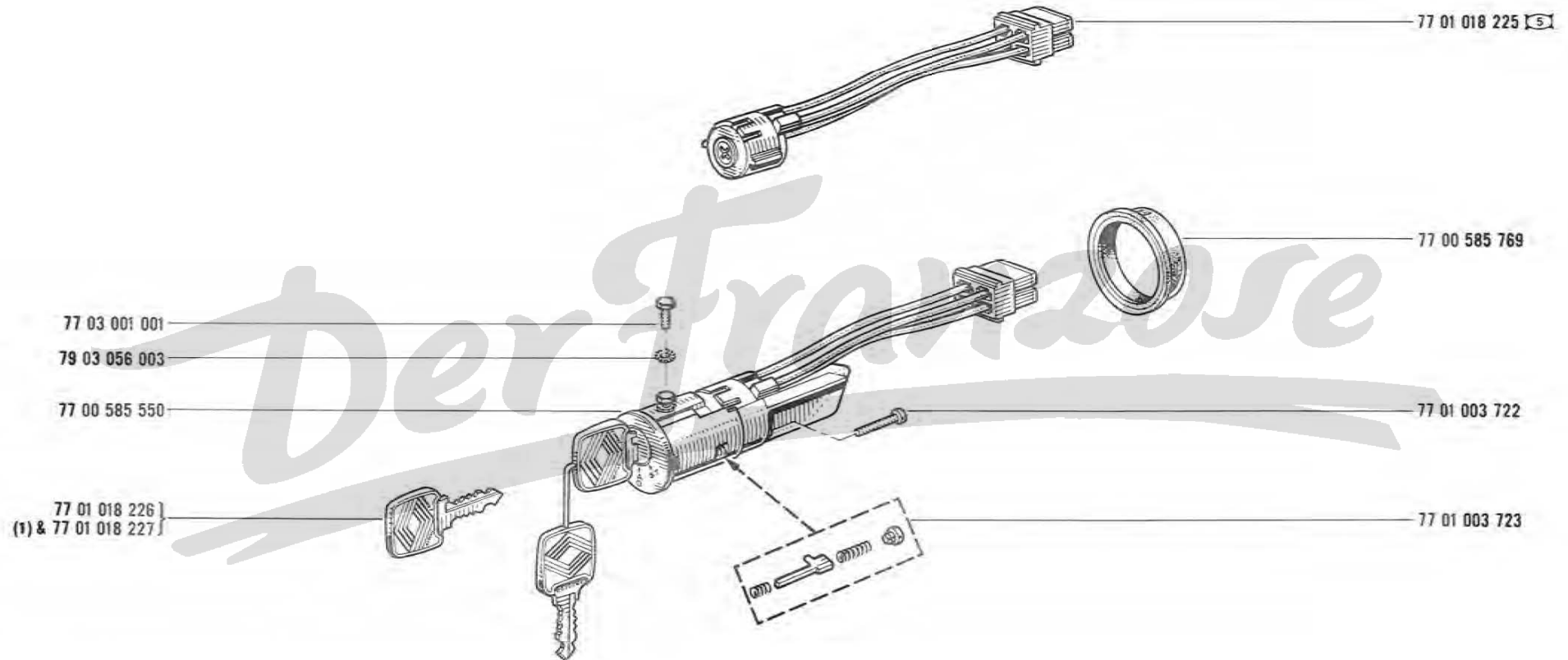
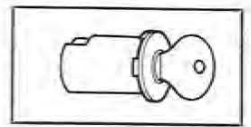

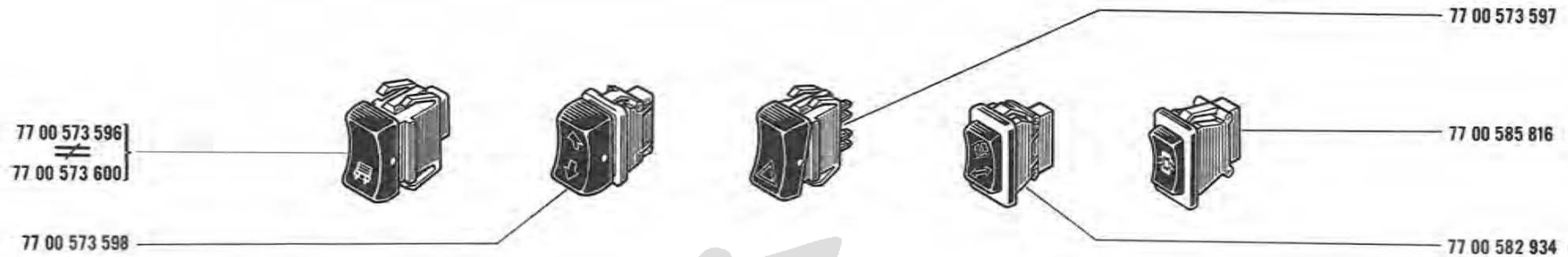
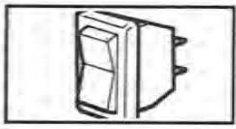

Der Franzose

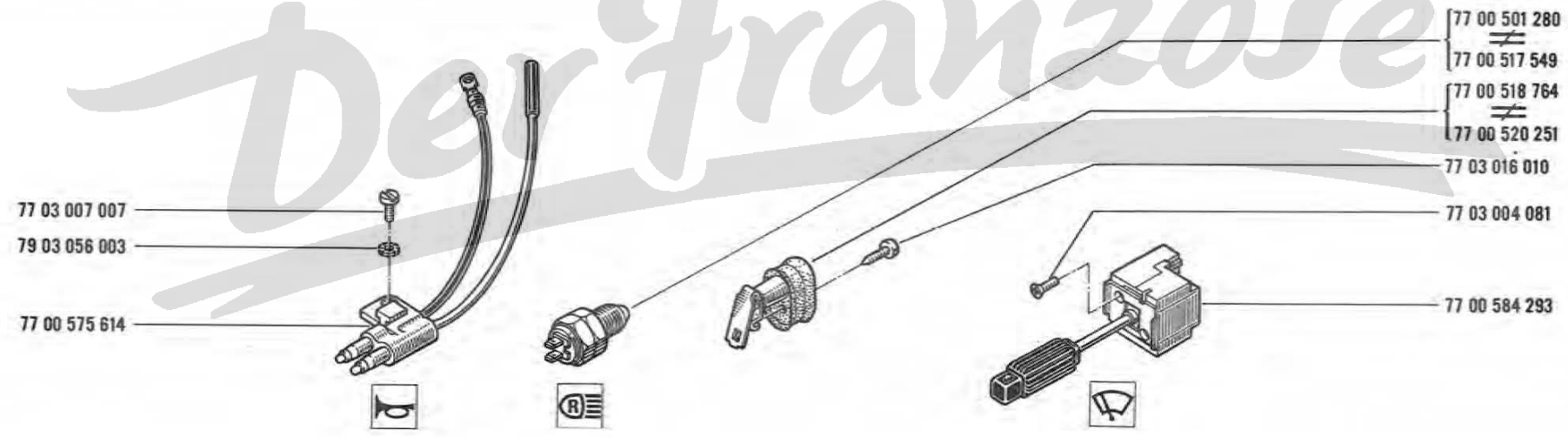

84.30

A P.R. 1030

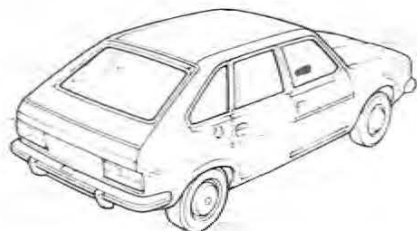

84.30

A P.R. 1030

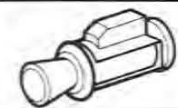

77 00 578 335

77 01 005 398

77 01 018 650

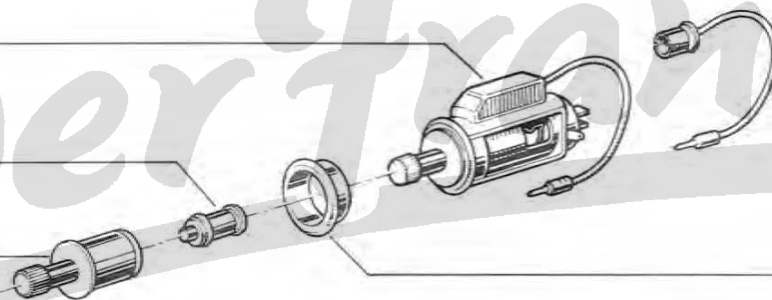

77 01 017 105

77 01 018 651

Der Franzose

85.01

A P.R.1030



85.01

A P.R.1030



77 01 200 460

79 03 032 008
77 03 056 012

77 01 200 457

77 01 200 449

77 01 018 326

77 01 018 325

77 01 200 536

79 03 032 055
79 03 056 046

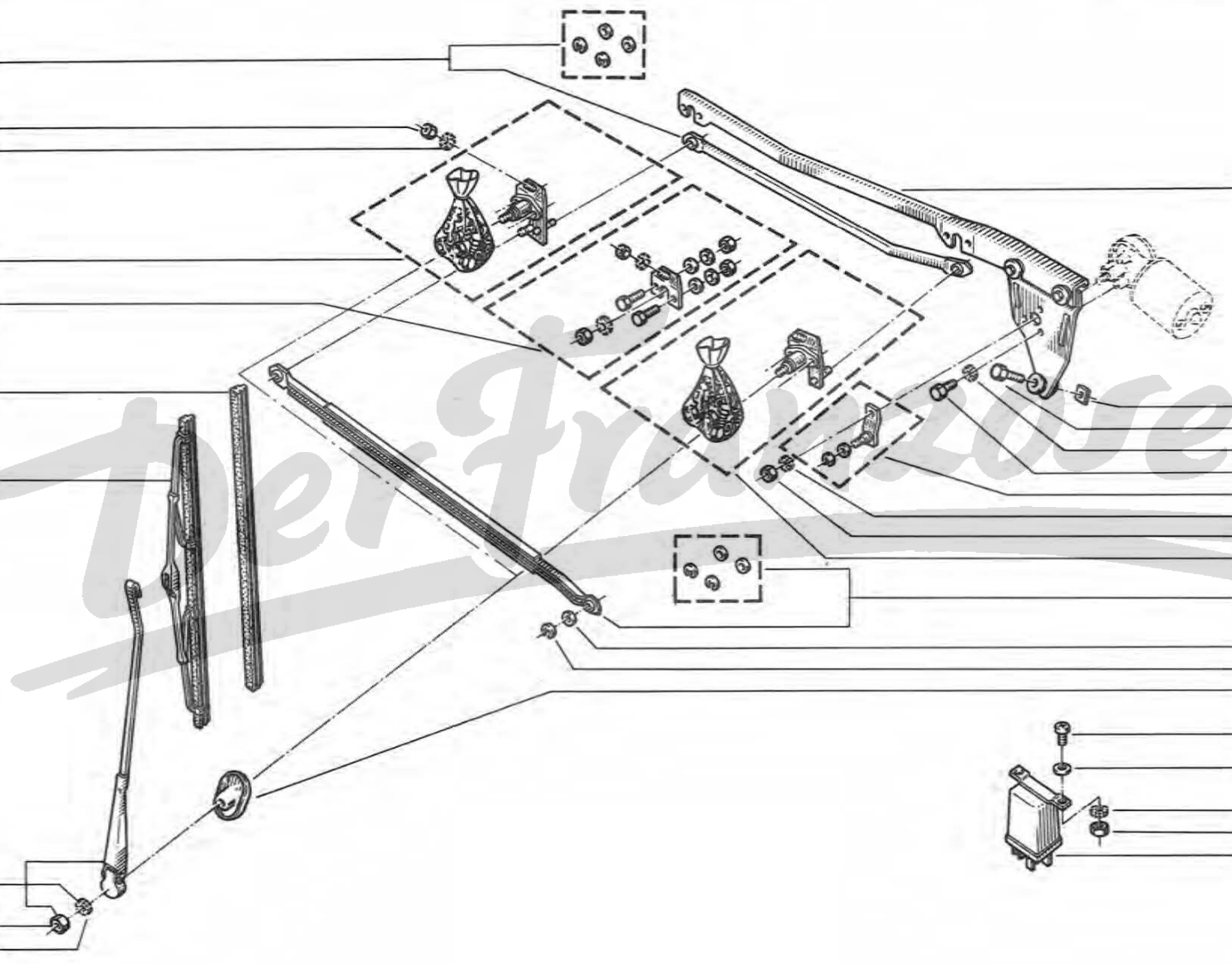

77 01 018 327

77 03 044 024

77 03 001 125

79 03 056 008 ☒

77 03 001 022

77 01 200 216

79 03 056 008

79 03 032 070

77 01 200 458

77 01 200 459

77 03 053 030

77 03 066 151

77 00 590 421

77 03 007 013

79 03 053 025

79 03 056 005 ☒

79 03 032 006

77 00 584 294

85.10

A P.R.1030



85.10

A P.R.1030

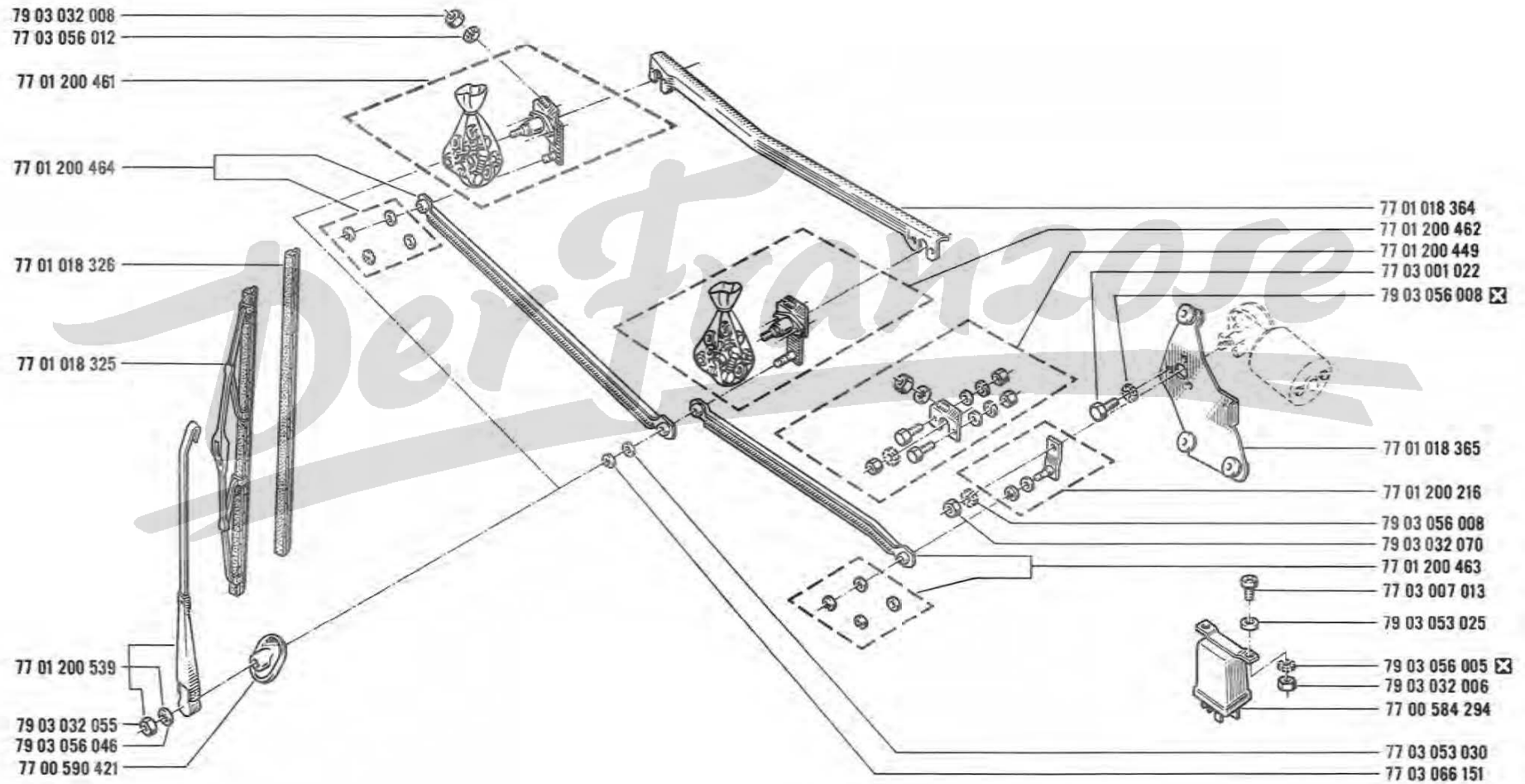

85.20

A P.R.1030

85.20

A P.R.1030

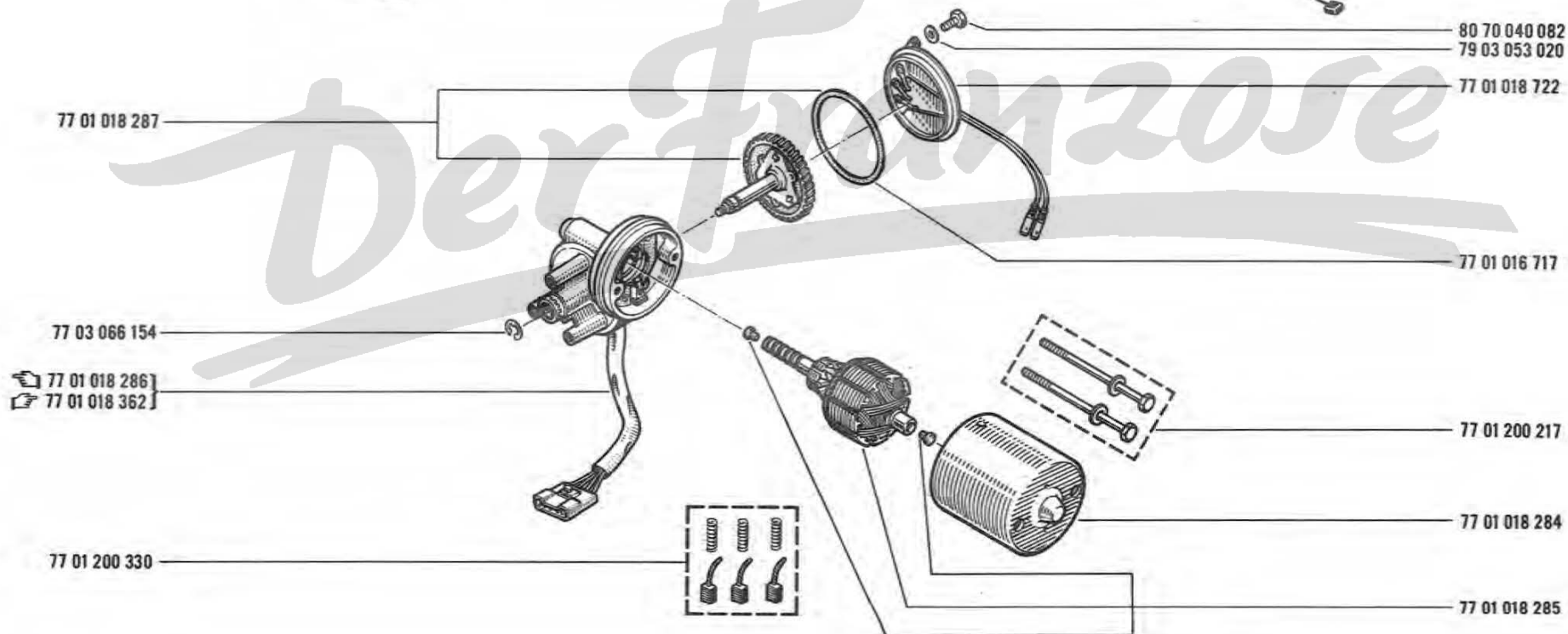
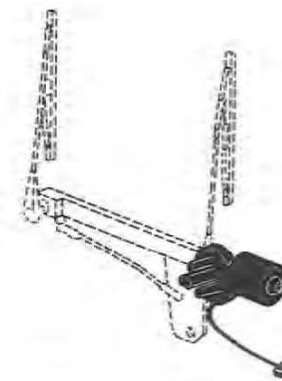
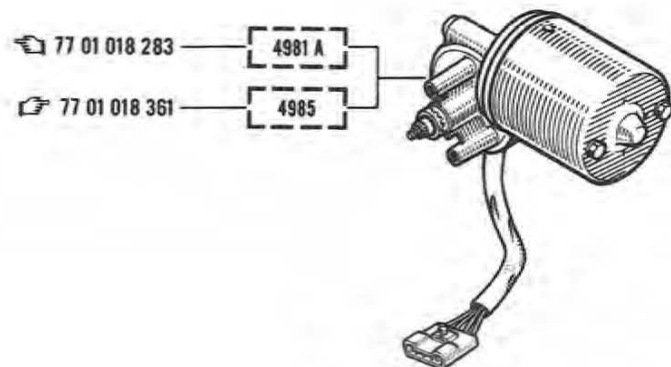

86.01

A P.R.1030



86.01

A P.R.1030

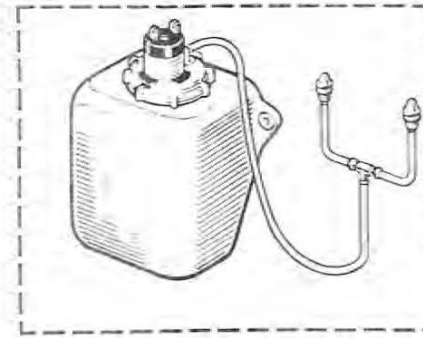
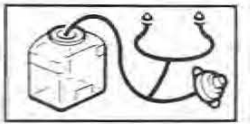

77 00 576 027

77 01 017 750

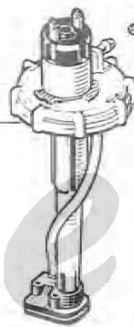

08 54 834 200

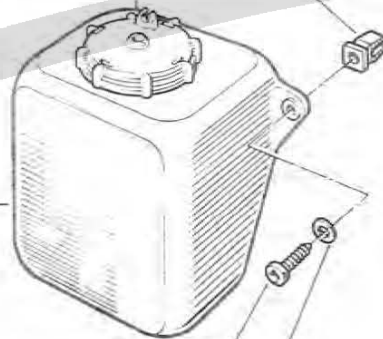

77 01 017 755

77 03 016 024

79 03 056 036

77 01 016 512 (A=3,50) \approx 1m

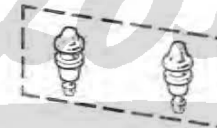

77 01 200 305

77 01 016 511

77 01 016 512 (A=3,50) \approx 1m

77 01 002 952



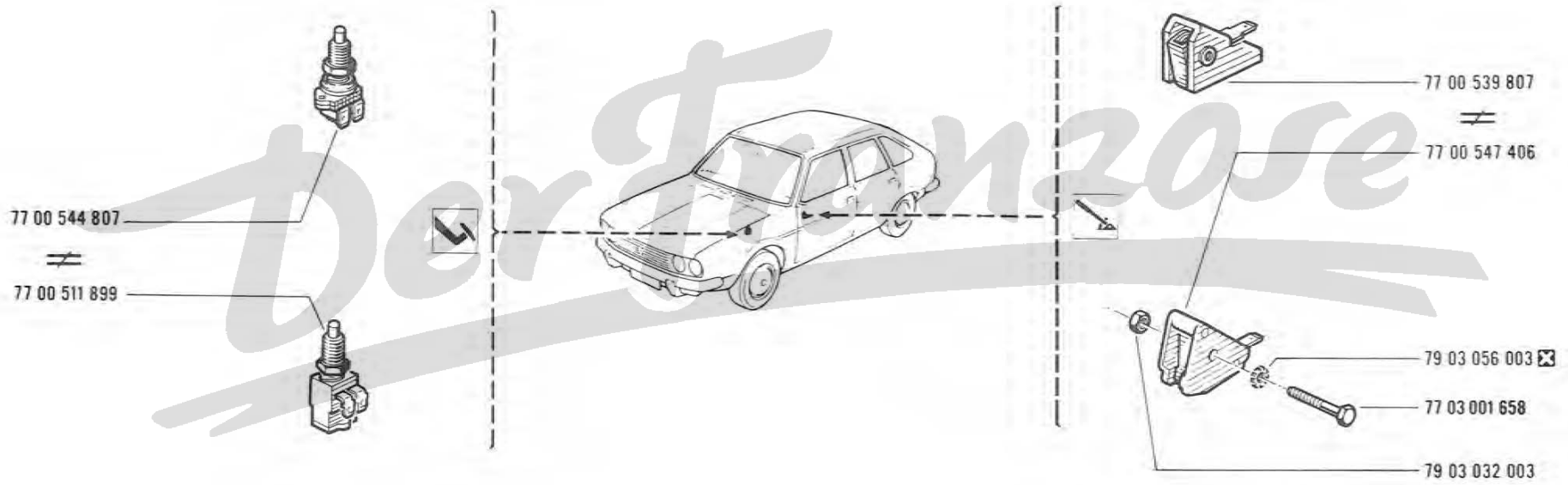

87.01

A P.R.1030

87.01

A P.R.1030

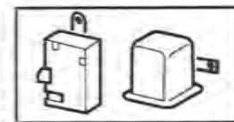

77 00 574 150
77 00 580 374
79 03 056 021
77 03 007 005

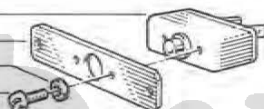

77 00 577 056

79 03 032 006

79 03 056 005 ☒

77 03 001 008

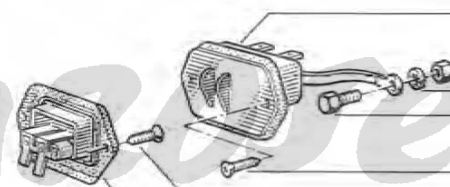

77 03 016 187

77 03 016 187

77 00 577 055

77 00 575 871



77 01 007 933

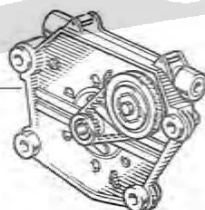

77 00 576 725

77 00 582 700



87.30

A P.R.1030



87.30

A P.R.1030

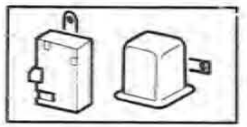

77 00 585 018

77 00 577 735

08 55 898 600

08 55 545 600

08 55 824 000

5A
8A
16A

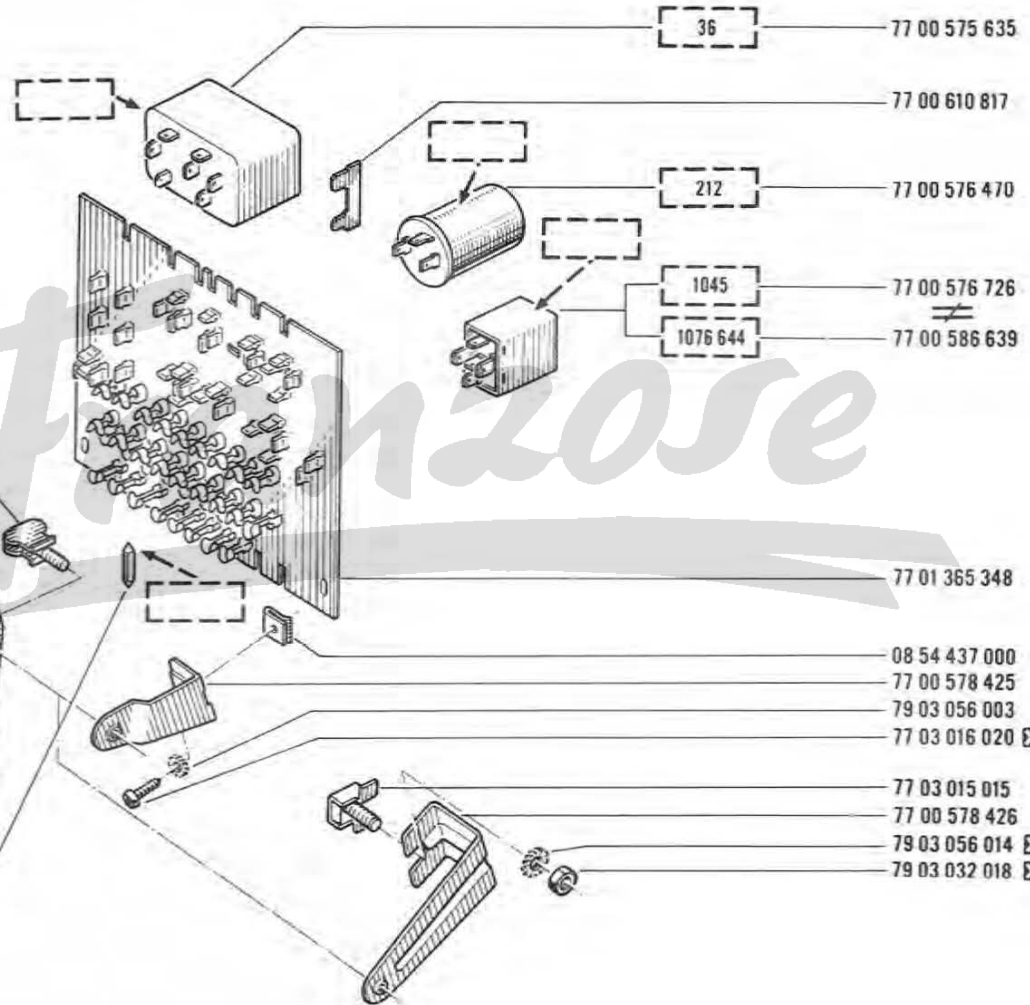

36

77 00 575 635

77 00 610 817

212

77 00 576 470

1045

77 00 576 726

1076 644

77 00 586 639

77 01 365 348

08 54 437 000

77 00 578 425

79 03 056 003

77 03 016 020

77 03 015 015

77 00 578 426

79 03 056 014

79 03 032 018

87.50

A P.R. 1030



87.50

A P.R. 1030

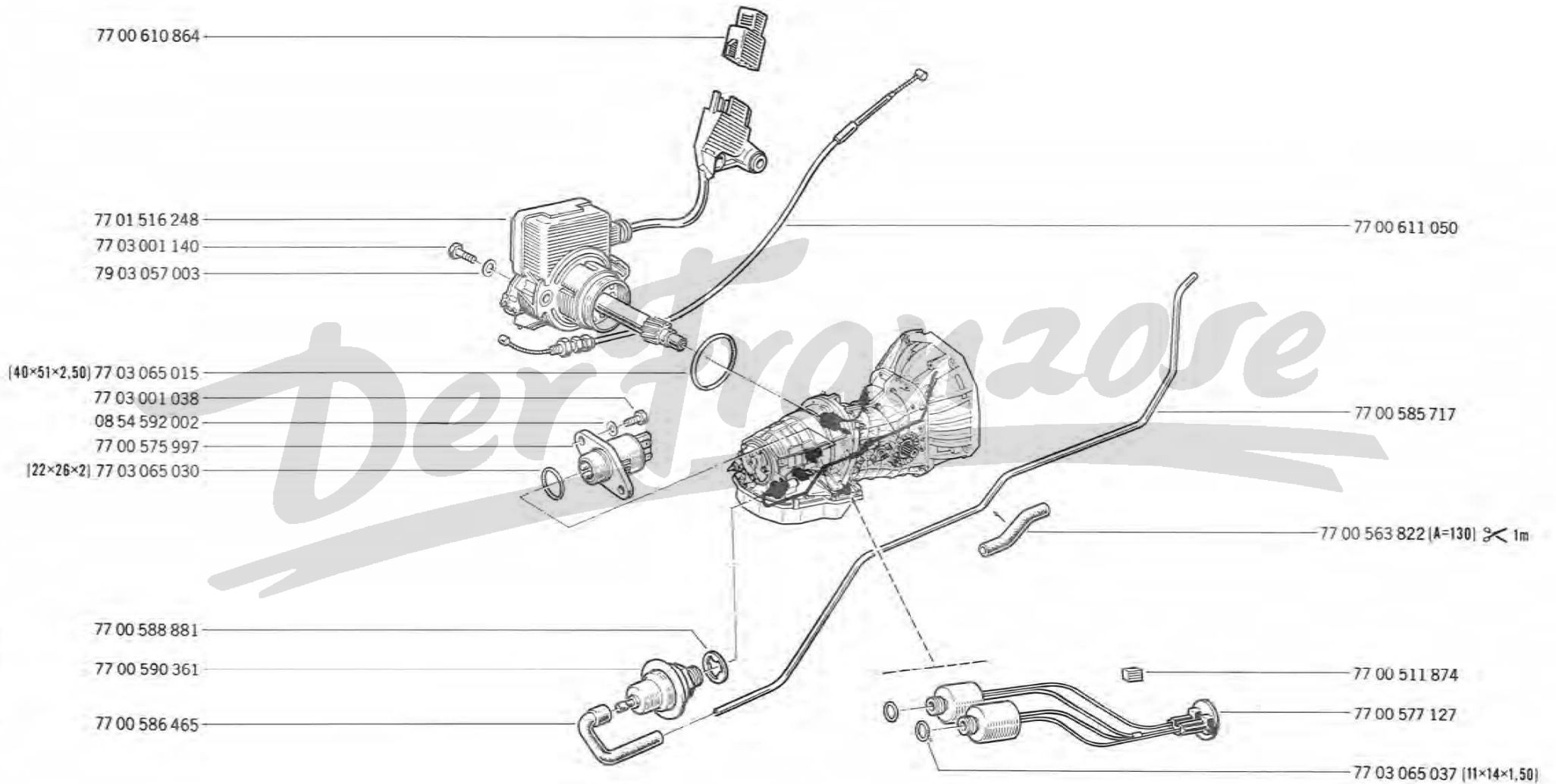
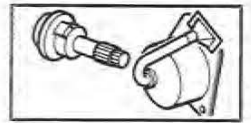

88.01

A P.R.1030

88.01

A P.R.1030

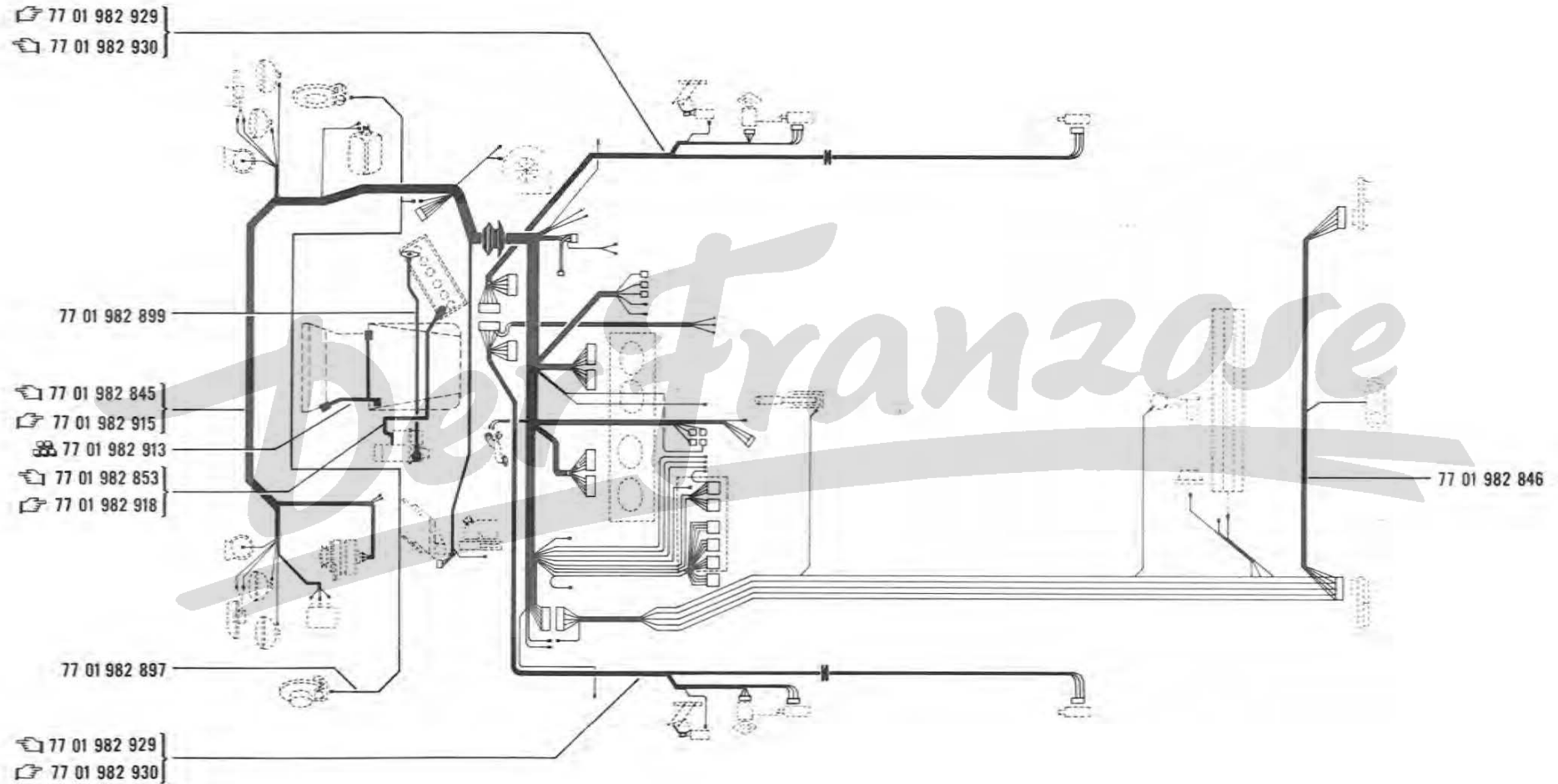
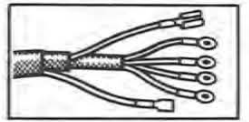

90.15

C P.R. ...

90.15

C P.R. ...

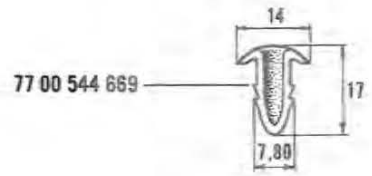

77 00 544 669

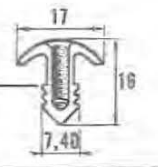

77 00 520 240

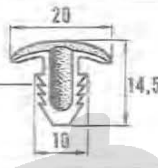

77 00 532 282

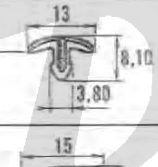

77 00 586 441

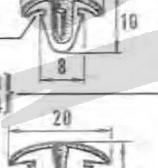

08 54 698 200

[A=3][B=11][C=7] 77 03 074 011
[A=4,50][B=10,80][C=8] 77 03 074 014

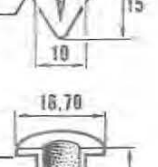

77 00 525 875

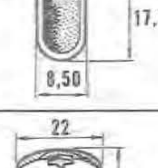

77 03 074 022

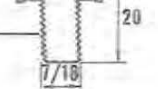

4 77 03 074 031
5 77 03 074 044
15 77 03 074 021

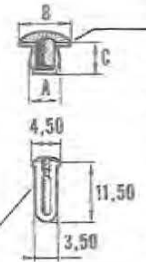

77 03 074 037 [A=6,30][B=8,50][C=8]
08 55 880 000 [A=5,80][B=10][C=6,40]
08 55 641 700 [A=9][B=13][C=7]
[A=8,50][B=11][C=7,25] 77 03 074 013
[A=8,50][B=11][C=8,75] 08 55 887 800
[A=9,50][B=13][C=7,70] 08 55 617 400
[A=11,70][B=14][C=8,30] 77 03 074 025

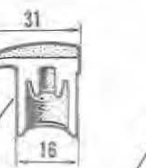

[A=19,30][B=16,50][C=9,40] 77 00 521 999
[A=15][B=12,50][C=8] 77 00 521 870

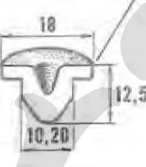

06 07 582 900

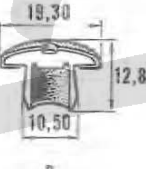

06 05 385 900

06 05 386 000

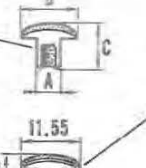

06 05 535 700

06 08 393 000

77 03 074 015



[A=10][B=17][C=2] 77 00 519 772
[A=11][B=18][C=2] 77 03 074 005
[A=12][B=19][C=2] 77 00 519 773
[A=14,20][B=23,60][C=3,60] 77 00 531 187
[A=24,60][B=31,60][C=2] 77 00 520 357
[A=28][B=39][C=3,60] 77 03 074 003
[A=30][B=41][C=3,60] 77 00 526 791
[A=33][B=43,50][C=3,60] 77 00 531 188
[A=36][B=47][C=3,60] 77 00 519 771
[A=38,10][B=48,41][C=3,60] 77 03 074 010
[A=40][B=50,50][C=3,60] 77 00 523 800
[A=20,50][B=28,60][C=3] 77 00 519 770

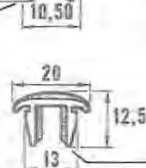

77 00 579 900

77 03 074 047

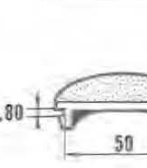
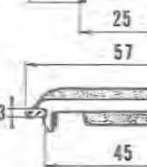
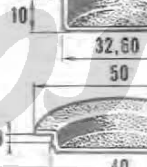
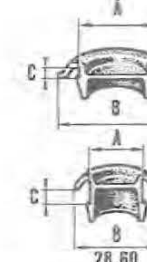
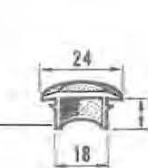
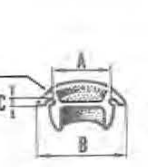
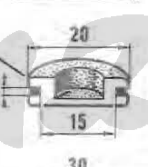
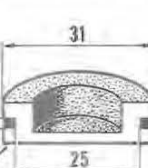
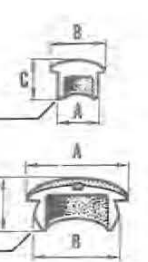

77 03 074 048 [A=18,10][B=29][C=3,40]
77 00 523 857 [A=15][B=24,40][C=3,60]

77 03 074 019 [A=13][B=19,60][C=4]
77 00 548 585 [A=45][B=52][C=5,50]
77 03 074 001 [A=23,20][B=30,60][C=3,70]
77 00 520 358 [A=14,20][B=21,20][C=2,50]

77 00 531 186

77 03 074 032

77 03 074 024

[77 03 074 036 [A=35][B=43]
77 03 074 034 [A=41][B=49,50]

06 08 098 500

77 00 522 963

77 00 548 586

79 03 074 053

90.20

C P.R. ...

- [A=0,60 ⇨ 1] [B=4,30] [C=12] 77 03 078 017
- [A=0,70 ⇨ 0,80] [B=5] [C=12] 08 54 357 200
- [A=0,50 ⇨ 0,60] [B=9] [C=12] 08 54 771 300
- [A=1,40 ⇨ 1,90] [B=10] [C=14] 08 54 423 700
- [A=1,20] [B=12] [C=14] 77 01 014 410
- [A=0,90] ⇨ 1,50 [B=13,50] [C=15] 08 55 502 700
- [A=2] ⇨ 2,20 [B=14,50] [C=14] 08 54 880 500
- [A=0,80 ⇨ 1,20] [B=16,50] [C=14] 08 55 801 500
- [A=0,50 ⇨ 2,50] [B=2,80] [C=12] 77 00 501 450
- [A=0,70 ⇨ 2,10] [B=6] [C=12] 77 03 078 016
- [A=2,50] [B=12] [C=14] † 77 00 530 833
- [A=2 ⇨ 3] [B=6,10] [C=12,70] 77 03 078 001
- [A=1,50 ⇨ 2,30] [B=7] [C=10] 08 55 560 400
- [A=0,70 ⇨ 2,10] [B=9] [C=14] 08 55 438 700
- [A=3 ⇨ 4,40] [B=9,10] [C=12] 08 55 155 000
- [A=4 ⇨ 7] [B=11] [C=14] 77 03 078 007
- [A=0,70 ⇨ 1,50] [B=12,60] [C=14] 77 03 078 023
- [A=1,25 ⇨ 3] [B=13] [C=15] 77 00 543 147
- [A=5 ⇨ 7] [B=6] [C=13] 08 54 355 600

- [A=1] 08 55 595 700
- [A=1 ⇨ 2] 77 03 078 012
- [A=0,90] 77 03 076 039

[A=0,5 ⇨ 1,80] 77 00 541 423

[A=0,60 ⇨ 1,50] † 77 00 527 341
77 03 078 038

[A=0,60 ⇨ 1,60] 77 03 078 019

[A=1,60] 08 55 777 500

[A=1,20] 08 55 665 100

[A=1 ⇨ 1,5] 77 03 078 006

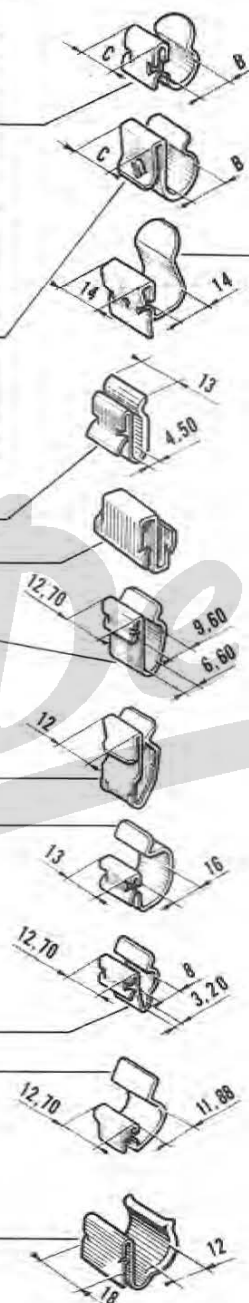

[A=0,70 ⇨ 1,50] 77 03 078 022

[A=0,70] 77 03 078 031

77 00 527 719 †
77 00 539 575 † [A=2 ⇨ 4]
79 03 078 013

[A=0,60 ⇨ 0,90] † 77 00 534 047
77 03 078 039

[A=0,60 ⇨ 1] 77 00 541 058

[A=1,40] 77 03 078 002

[A=2] 08 54 610 400

[A=2] 77 03 078 029

[A=0,80 ⇨ 1,20] 77 00 534 437

[A=0,50 ⇨ 3] 08 55 795 900

[A=0,70 ⇨ 2,10] 08 55 802 200

[A=0,70 ⇨ 2,10] 08 55 799 600

[A=1,50] 79 03 076 039

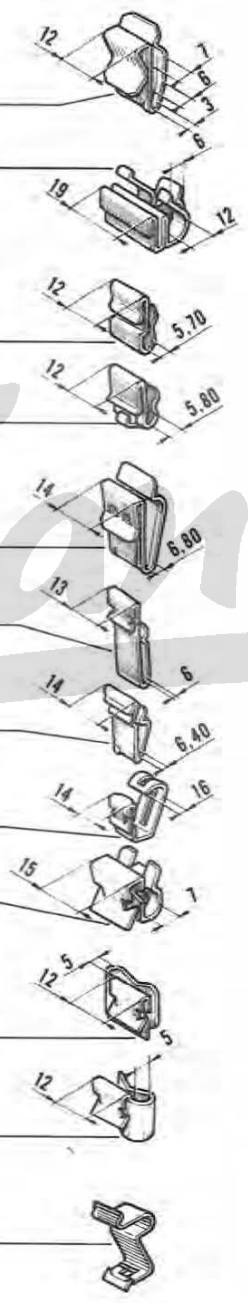

90.20

C P.R. ...

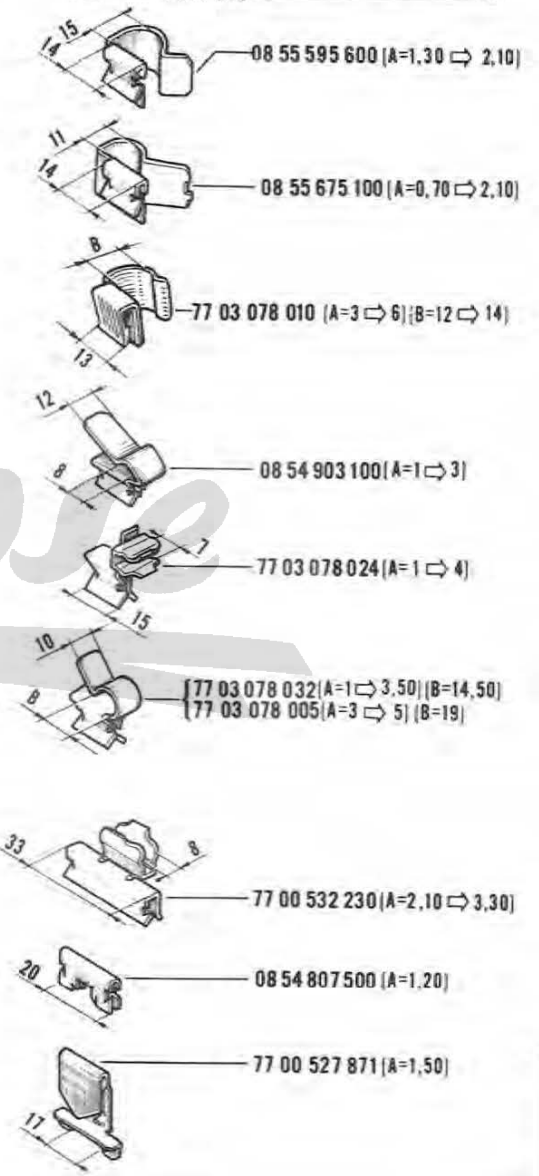
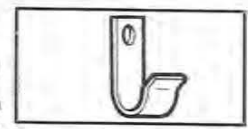

08 55 595 600 [A=1,30 ⇨ 2,10]

08 55 675 100 [A=0,70 ⇨ 2,10]

77 03 078 010 [A=3 ⇨ 6] [B=12 ⇨ 14]

08 54 903 100 [A=1 ⇨ 3]

77 03 078 024 [A=1 ⇨ 4]

77 03 078 032 [A=1 ⇨ 3,50] [B=14,50]
77 03 078 005 [A=3 ⇨ 5] [B=19]

77 00 532 230 [A=2,10 ⇨ 3,30]

08 54 807 500 [A=1,20]

77 00 527 871 [A=1,50]

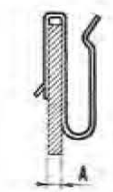

90.25

D P.R. ...

- [A=4,50][B=26][C=8] 06 07 239 200
- [A=4,50][B=32,50][C=12] 07 06 204 200
- [A=6,50][B=54,50][C=25] 04 25 019 800
- [A=6,50][B=49][C=20] 06 05 067 200
- [A=6,50][B=32,50][C=12] { 07 06 284 700
00 72 572 100
- [A=6,50][B=36,50][C=19] 06 02 989 600
- [A=7,50][B=59][C=16] 77 00 586 622
- [A=8,50][B=54,50][C=25] 06 04 349 200
- [A=8,50][B=49][C=20] 06 06 551 402
- [A=8,50][B=32,50][C=12] { 00 77 671 700
07 06 334 100
- [A=9,50][B=50][C=13] 06 08 127 700
- [A=7,5][B=65][C=13] 77 00 525 164

77 00 564 549

04 25 559 100

77 03 078 026

08 55 845 200

77 00 612 855

- [B=31][C=5,50] 77 03 078 018
- [B=21][C=6] 08 54 146 600
- [B=21,50][C=11] 08 54 699 800

77 03 076 047

77 03 078 021 [C=7↔9]

77 00 521 580

- [77 03 078 011 [B=25][C=5,30]
- [08 55 821 100 [B=21][C=3,20]

- [A=6,25][B=25][C=12,50] 02 51 026 800
- [A=7][B=40][C=16] 06 03 518 300
- [A=7][B=52][C=16] 06 03 400 600
- [A=7][B=24][C=8] 77 00 513 461
- [A=8][B=50,50][C=23] 77 00 515 923
- [A=8][B=46,50][C=17] 77 03 083 053
- [A=8,50][B=40][C=26] 06 07 290 700

77 00 589 329 77 00 613 133

[A=6][B=37][C=16] 77 00 585 645

- [A=5][B=15][C=30][D=15] 06 08 517 502
- [A=4,30][B=7][C=19][D=8] 06 08 544 202
- [A=6,25][B=10][C=27][D=20] 05 53 594 000

06 08 170 900

77 00 512 381

77 03 078 004

[A=9][B=57][C=20] 77 00 588 268

77 00 541 057

77 03 076 040

77 00 528 263

90.25

D P.R. ...



77 00 511 353

77 00 610 810

77 00 538 016

77 00 520 545

77 00 531 986

77 00 513 702

77 00 530 580

77 00 568 929

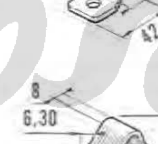
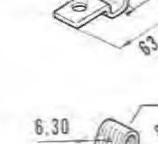
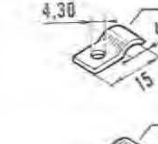
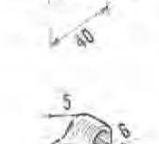
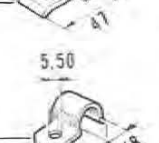
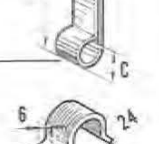
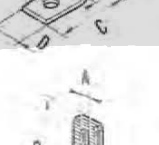
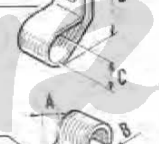
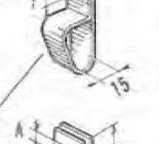
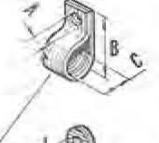
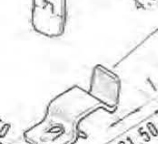
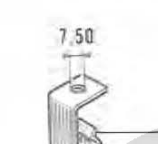
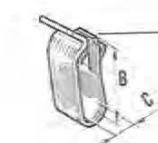
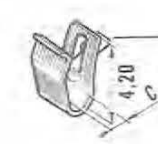
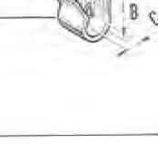
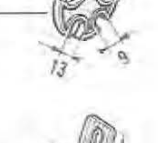
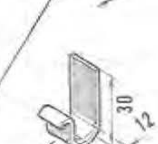
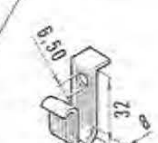
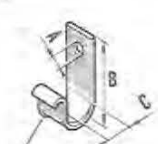

90.30
C P.R. ...

90.30
C P.R. ...



[A=9] 77 00 520 411		[A=6] [B=2,10 ⇨ 3,30] † 77 00 516 961 [A=6] [B=0,50 ⇨ 2] 77 03 079 012 [A=6] [B=1 ⇨ 2] 77 00 516 887			77 03 079 023 [A=4,76] [B=8,50]
[A=5] 77 03 079 013		[A=6] [B=2,50] 08 54 924 500			[77 03 079 046 [A=8] [B=4,80] 77 03 079 044 [A=10] [B=4,80]
[A=6] 77 03 079 017		[A=4,76] [B=5 ⇨ 8] 77 03 079 011			77 03 079 039 [A=4,90]
[A=4,75] 08 55 928 900 [A=6] 08 55 658 400 [A=8] 77 01 002 197		[A=4,76] [B=5 ⇨ 8] 77 03 079 010			[77 03 079 053 [A=4,80] [B=4,80] [C=4,80] 77 00 521 396 † [A=4,80] [B=4,80] [C=6,00] 77 03 079 037 [A=4,90] [B=4,90] [C=6] 77 00 542 616 † [A=8] [B=8] [C=4,80] 77 03 079 030 [A=8,20] [B=8,20] [C=4,90] 77 03 079 038 [A=8] [B=8] [C=4,80]
[A=8,50] { † 77 00 532 229 77 03 079 048 }		[A=6] [B=0,50 ⇨ 2] 77 00 544 467			[77 03 079 032 [A=4,80] [B=4,80] 77 03 079 045 [A=8,50] [B=4,80]
[A=4,80] 79 03 079 003 [A=6,00] 77 03 079 040 [A=8,50] 77 03 079 024 [A=4,90] 77 03 079 034 [A=10,70] 77 00 519 655 [A=6,00] 77 03 079 005		[A=6,50] 08 54 837 000			77 03 079 009 [A=4,76]
[A=4,80] 77 03 079 051		[A=4,76] [B=8,50] 77 03 079 022			77 03 081 002 [A=4,80]
[A=4,80] 77 00 539 638		[A=4,80] [B=4,80] 77 03 079 052 [A=6,00] [B=4,80] 77 03 079 054 [A=8,50] [B=8,50] 77 03 079 025 [A=4,90] [B=4,90] 77 03 079 036 [A=6] [B=6] 77 00 537 400			77 01 365 173 [A=4,50] [B=4,80] [C=8] [D=6,20]
[A=5] 77 03 079 060		[A=4,50] [B=8] 77 01 002 196 [A=4,50] [B=4,50] 77 03 079 028 [A=4,50] [B=6,00] 08 55 658 600			
[A=2,50 ⇨ 3,50] 77 03 079 027					
[A=2,60] 77 03 079 033					

90.35

B P.R. ...

90.35

B P.R. ...

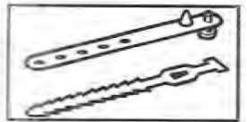

- [A=175] 77 00 537 295
- [A=232] 77 03 085 003
- ≠
- [A=232] 77 00 515 140
- [A=359] 77 03 085 005
- [A=265] 50 03 085 001

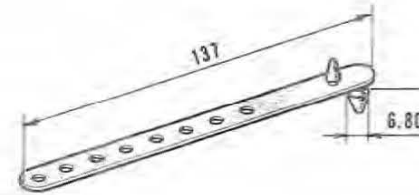
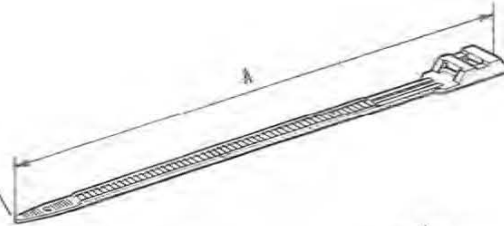

08 55 152 300

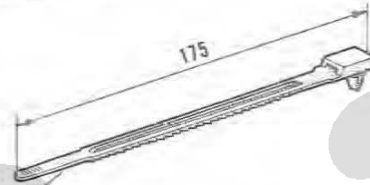

77 03 085 004

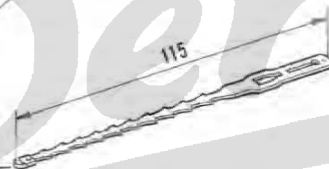

08 55 807 500

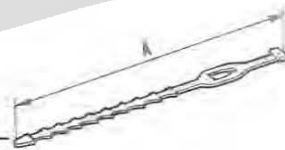

- [A=85] 77 00 514 895
- [A=173] 08 55 795 000

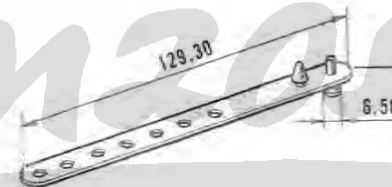

77 01 001 627

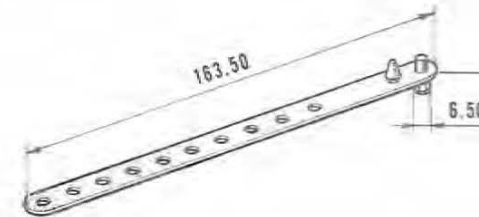

77 03 085 002

Der Franzose

90.40

A P.R. ...

90.40

A P.R. ...



- [A=7 ⇨ 9] 08 55 968 900
- [A=11 ⇨ 13] 08 55 538 600
- [A=12 ⇨ 14] 08 55 841 600
- [A=13 ⇨ 15] 08 02 107 900
- [A=16 ⇨ 18] 08 55 595 300
- [A=18 ⇨ 20] 08 55 811 700
- [A=20 ⇨ 22] 08 55 830 100
- [A=81] 77 03 083 025
- [A=100] 08 02 114 200



08 52 198 700 [A=41 ⇨ 57]

- [77 03 083 051 [A=7 ⇨ 11]
- [77 03 083 058 [A=11 ⇨ 18]
- [77 03 083 054 [A=40 ⇨ 55]

- [A=15 ⇨ 18] 77 03 083 032
- [A=17 ⇨ 20] 77 03 083 001
- [A=22 ⇨ 25] 77 03 083 002
- [A=27 ⇨ 30] 77 03 083 003
- [A=37 ⇨ 40] 77 03 083 006
- [A=87 ⇨ 90] 77 03 083 021

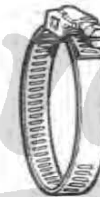

- [08 55 411 200 [A=17]
- [77 00 519 065 [A=40]

- [77 03 083 033 [A=10 ⇨ 16]
- [77 03 083 019 [A=16 ⇨ 27]
- [77 01 400 362 [A=32 ⇨ 50]
- [77 03 083 004 [A=40 ⇨ 60]
- [77 03 083 005 [A=60 ⇨ 80]

- [A=10 ⇨ 17] 77 00 515 235
- [A=13 ⇨ 20] 77 03 083 015
- [A=25 ⇨ 45] 77 01 400 185



- [77 03 083 016 [A=8 ⇨ 11]
- [77 03 083 009 [A=11 ⇨ 15]

- [77 03 083 023 [A=55]
- [77 03 083 066 [A=62]
- [77 03 083 026 [A=70]
- [77 03 083 036 [A=77]

77 03 083 038 [A=12]

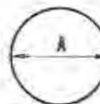

90.50

A P.R. ...

90.50

A P.R. ...



- (B=4) { (A=1 ⇨ 1,40) 05 55 437 800
(A=1,90 ⇨ 2,50) 05 55 506 400
(A=3 ⇨ 3,60) 05 55 506 800 }
- (B=5,20) { (A=1 ⇨ 1,40) 05 55 506 100
(A=1,90 ⇨ 2,50) 05 55 506 500
(A=3 ⇨ 3,60) 05 55 506 900 }
- (B=6,20) { (A=1 ⇨ 1,40) 05 55 506 200
(A=1,90 ⇨ 2,50) 05 55 506 600
(A=3 ⇨ 3,60) 05 55 507 000 }
- (B=8,25) { (A=1 ⇨ 1,40) 05 55 506 300
(A=1,90 ⇨ 2,50) 05 55 506 700 }
- (B=8,50) (A=2,50 ⇨ 3) 08 54 411 200

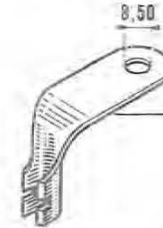
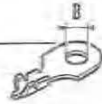

06 04 655 900 (A=6,50)

- (D=8,50) (C=6,20) 77 00 511 771
- (D=8,50) (C=7,20) 06 08 551 100
- (D=10,50) (C=7,20) 06 07 074 900

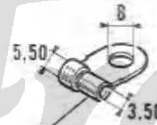

06 07 823 100 (A=6,50)

(A=5) 04 25 667 800



{ 06 07 075 000
77 03 097 057 } (A=6,50)

- (B=6,50) 06 08 044 900
- (B=8,50) 06 08 187 600

(A=1 ⇨ 1,40) 08 54 698 300



(A=1 ⇨ 3) 08 54 259 100



06 08 180 800 (A=6,50)

(A=1,90 ⇨ 2,50) 08 54 698 400

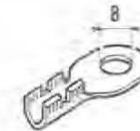

{ 06 07 075 100 (A=6,50) (B=8,50)
06 07 081 400 (A=6,50) (B=10,50) }

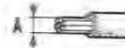

Der Franzose

90.55

B P.R. ...

90.55

B P.R. ...



(B=6.35) { [A=0.50 ⇔ 1.40] 08 53 990 800
 [A=1 ⇔ 2.20] 08 55 893 400
 08 53 990 700
 [A=1.40 ⇔ 3] 77 00 554 186
 [A=1 ⇔ 1.40] 77 00 565 822
 (B=6.30) { [A=1.90 ⇔ 2.50] 77 00 565 823

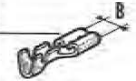

(B=6.30) { [A=1 ⇔ 2.50] 77 03 097 019
 [A=2 ⇔ 3] 77 03 097 032
 (B=5) { [A=0.80 ⇔ 1.90] 77 03 097 012
 [A=1.40 ⇔ 2.20] 77 03 097 013



[A=1.20 ⇔ 2.20] 08 53 991 100

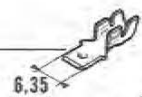

[A=1 ⇔ 2.20] 77 03 097 036

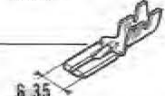

[A=1 ⇔ 2.20] 08 53 990 500
 [A=1 ⇔ 2.50] 77 03 097 020

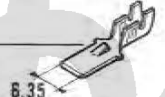

77 03 097 047



[A=1.20 ⇔ 2.80] 77 00 565 819

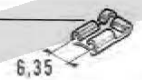

[A=1.20 ⇔ 2.80] 08 55 843 900

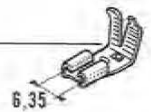

[A=1 ⇔ 1.90] 77 00 517 551

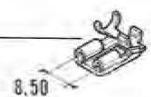

77 00 502 812 (A=0.80 ⇔ 1.90)

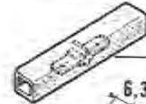

08 54 096 700

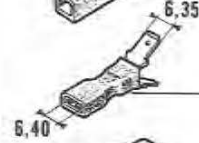

08 55 775 000

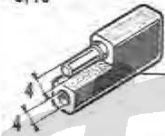

77 00 560 547 (A=1 ⇔ 1.40)



77 00 509 620

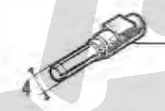

77 00 543 497 (A=1 ⇔ 1.40)



77 00 542 806 (A=0.80 ⇔ 1.40)



77 00 543 498 (A=1 ⇔ 1.40)

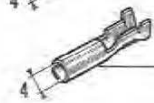

77 00 557 972 (A=0.80 ⇔ 1.40)



77 01 017 823

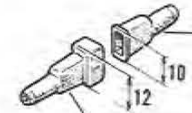

08 54 769 300

08 54 769 200

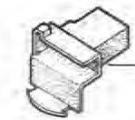

77 00 509 023



77 00 516 029



50 00 080 369



08 55 628 700 (A=2.20 ⇔ 3.40)



Der Franzose

90.60
A P.R.1030



90.60
A P.R.1030

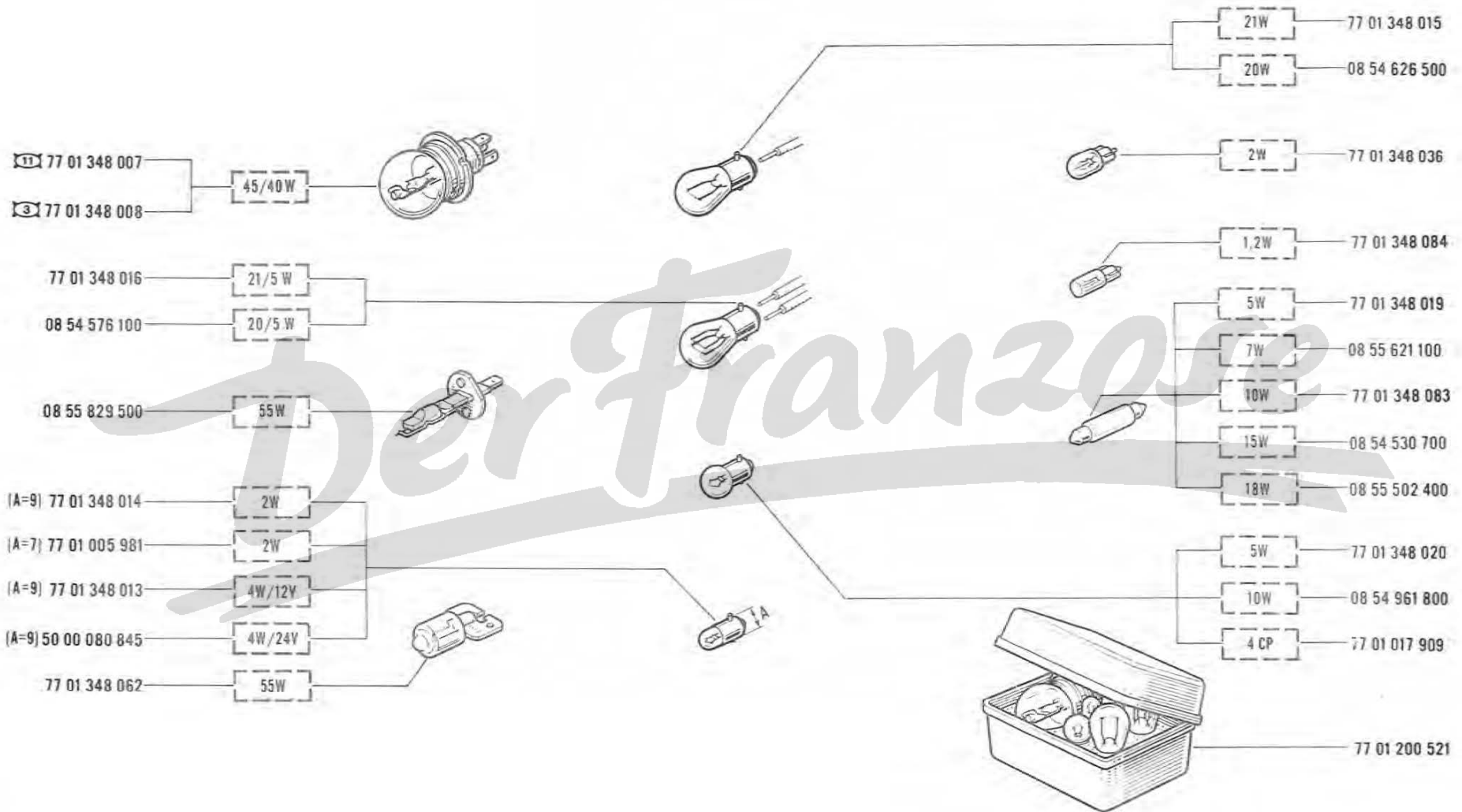
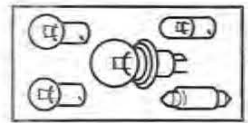



- 1 — Numéro de pièce unitaire - Styk-nummer - Einzelteil-Nr. - Part No. of single part - Número de la pieza - Numero di particolare unitario - Nummer van het afzonderlijke onderdeel - Detaljnummer styck
 2 — Numéro de collection - Kollektion-nummer - Satz-Nr. - Part No. of set - Número de la colección - Numero di collezione - Nummer van de set - Detaljnummer sats
 3 — Quantité par collection - Antal pr. kollektion - Menge pro Satz - Quantity per set - Cantidad por colección - Quantità per collezione - Aantal per set - Antal i satsen

1	2	3	1	2	3	1	2	3
06 06 635 000	77 01 493 056	20	77 03 001 164	77 01 493 032	20	79 03 056 012	77 01 493 060	50
06 07 121 100	77 01 493 000	10	77 03 001 168	77 01 493 033	10	79 03 056 014	77 01 493 061	50
06 07 273 302	77 01 493 001	30	77 03 001 236	77 01 493 034	20	79 03 056 017	77 01 493 062	30
06 07 755 100	77 01 493 002	30	77 03 016 020	77 01 493 035	50	79 03 056 045	77 01 493 063	30
06 07 968 100	77 01 493 003	10	77 03 016 031	77 01 493 036	30	79 03 067 016	77 01 493 011	20
08 51 250 200	77 01 493 004	20	77 03 016 047	77 01 493 037	50			
08 52 397 800	77 01 493 006	30	77 03 034 011	77 01 493 038	10			
08 52 640 300	77 01 493 008	30	77 03 034 012	77 01 493 064	10			
08 53 513 000	77 01 493 009	10	77 03 046 012	77 01 493 039	20			
08 53 757 000	77 01 493 010	30	77 03 053 027	77 01 493 040	30			
08 54 329 100	77 01 493 012	30	77 03 055 007	77 01 493 022	100			
08 54 386 000	77 01 493 013	20	77 03 055 011	77 01 493 041	50			
08 54 610 000	77 01 493 014	20	77 03 055 013	77 01 493 042	50			
08 54 610 100	77 01 493 015	20	79 03 032 003	77 01 493 043	30			
08 54 971 500	77 01 493 016	10	79 03 032 007	77 01 493 044	50			
08 55 257 200	77 01 493 017	20	79 03 032 010	77 01 493 045	50			
08 55 649 800	77 01 493 018	50	79 03 032 012	77 01 493 046	50			
08 55 658 400	77 01 493 019	10	79 03 032 018	77 01 493 047	50			
08 55 689 300	77 01 493 020	20	79 03 032 023	77 01 493 048	30			
08 55 848 800	77 01 493 021	20	79 03 044 011	77 01 493 007	10			
50 03 066 010	77 01 493 005	20	79 03 053 025	77 01 493 049	50			
77 00 518 963	77 01 493 023	20	79 03 053 028	77 01 493 050	100			
77 00 519 003	77 01 493 024	10	79 03 053 031	77 01 493 051	100			
77 03 001 024	77 01 493 025	30	79 03 053 038	77 01 493 052	30			
77 03 001 119	77 01 493 026	20	79 03 053 043	77 01 493 053	100			
77 03 001 120	77 01 493 027	30	79 03 053 045	77 01 493 054	50			
77 03 001 123	77 01 493 028	20	79 03 053 050	77 01 493 055	20			
77 03 001 138	77 01 493 029	20	79 03 053 157	77 01 493 057	30			
77 03 001 160	77 01 493 030	20	79 03 056 005	77 01 493 058	50			
77 03 001 162	77 01 493 031	20	79 03 056 008	77 01 493 059	50			

97.01
A PR.1030

97.01
A PR.1030

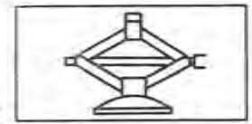

79 10 245 598



77 01 348 044

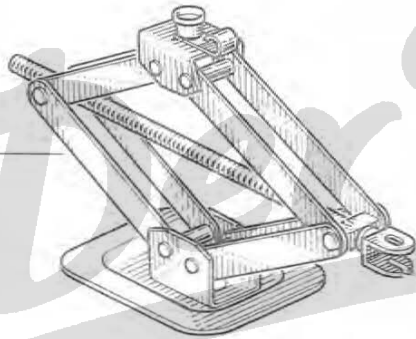

08 21 175 500

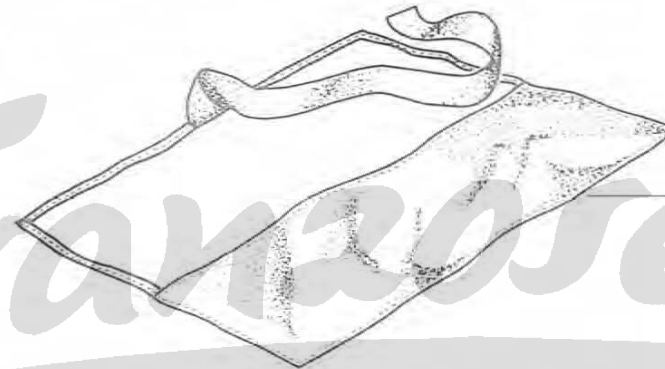

08 22 989 600 (A=420)

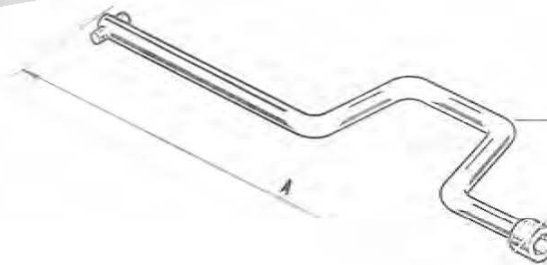

1	2	3	1	2	3	1	2	3	1	2	3	1	2	3
00 77 748 600	37 60	C1	06 08 420 300	16 30	01	08 53 064 700	19 01	C1	08 54 822 100	12 45	C1	50 03 001 092	80 01	01
04 25 667 800	90 50	XX	06 08 420 300	21 20	02	08 53 064 800	19 01	C1	08 54 834 200	16 30	C2	50 03 001 104	32 30	02
04 51 516 700	38 C1	01	06 08 420 300	21 30	01	08 53 064 900	19 01	C1	08 54 834 200	61 10	C4	50 03 001 220	12 45	C1
05 52 539 500	16 20	01	06 08 460 700	38 01	01	08 53 065 000	19 01	C1	08 54 834 200	86 01	02	50 03 001 220	12 70	C1
05 54 320 500	90 10	XX	06 08 460 700	34 10	08	08 53 521 500	77 01	20	08 54 884 800	16 20	C4	50 03 034 014	31 40	02
05 54 732 800	31 40	08	06 08 502 407	37 10	01	08 53 523 300	58 40	C1	08 54 971 400	12 45	C1	50 03 057 004	12 45	01
05 54 732 800	33 40	04	06 08 504 800	37 20	02	08 53 523 300	58 40	C6	08 54 979 000	77 10	24	50 03 057 004	12 70	C1
05 55 437 800	90 50	XX	06 08 517 007	19 50	04	08 53 561 300	52 20	C2	08 54 979 000	78 10	C2	71 14 414 242	58 01	02
05 55 506 100	90 50	XX	06 08 551 100	90 50	XX	08 53 659 600	37 01	C1	08 55 064 300	12 45	C1	71 29 155 334	77 10	04
05 55 506 200	90 50	XX	07 02 960 300	21 20	02	08 53 659 600	37 10	01	08 55 257 200	19 30	C3	71 29 155 334	77 10	12
05 55 506 300	90 50	XX	07 03 500 300	16 16	01	08 53 828 300	58 01	C2	08 55 257 200	46 10	02	71 29 155 334	78 01	16
05 55 506 400	90 50	XX	07 03 620 100	37 60	01	08 53 958 300	20 01	16	08 55 257 200	46 10	12	71 29 155 334	78 01	20
05 55 506 500	90 50	XX	07 05 304 104	55 01	02	08 53 980 400	61 30	C1	08 55 257 200	68 01	08	71 29 155 334	78 01	32
05 55 506 600	90 50	XX	07 05 304 104	55 10	02	08 53 990 500	90 55	XX	08 55 411 100	12 80	C2	71 29 155 334	78 10	XX
05 55 506 700	90 50	XX	07 05 837 200	37 20	01	08 53 990 700	90 55	XX	08 55 538 600	50 40	C2	71 29 155 334	78 10	03
05 55 506 800	90 50	XX	07 05 866 700	21 20	01	08 53 990 800	90 55	XX	08 55 545 600	87 30	XX	71 29 155 334	78 10	C4
05 55 506 900	90 50	XX	07 06 032 602	58 30	02	08 53 991 100	90 55	XX	08 55 595 300	50 40	01	71 29 155 334	78 10	C6
05 55 507 000	90 50	XX	07 06 216 800	37 70	01	08 53 996 444	12 35	02	08 55 599 900	33 40	02	71 29 155 334	78 10	C9
06 03 518 800	76 01	01	07 06 216 800	38 01	01	08 54 096 700	90 55	XX	08 55 621 100	50 60	C1	71 29 155 334	78 10	10
06 03 900 300	33 40	C2	07 06 326 300	32 01	02	08 54 119 700	32 30	C2	08 55 628 700	90 55	XX	71 29 155 334	78 10	11
06 03 936 600	32 30	02	07 06 331 302	33 40	02	08 54 119 700	34 30	01	08 55 650 500	88 20	XX	71 29 155 334	78 10	12
06 03 936 600	34 30	C1	07 06 706 300	19 40	01	08 54 209 000	19 30	C5	08 55 651 000	88 20	XX	71 29 155 334	78 10	14
06 04 346 300	50 70	C2	07 07 620 120	16 10	01	08 54 259 100	90 50	XX	08 55 651 100	88 20	XX	73 65 732 006	50 30	02
06 04 655 900	90 50	XX	07 07 620 423	16 10	01	08 54 268 900	17 01	C2	08 55 664 400	80 01	01	73 65 732 006	52 20	C1
06 05 385 800	90 10	XX	07 07 550 900	23 20	01	08 54 284 400	38 30	C2	08 55 698 900	16 16	C1	74 00 269 077	11 01	C1
06 07 074 900	90 50	XX	07 07 550 900	38 30	01	08 54 286 800	37 20	C1	08 55 699 000	16 16	01	74 00 460 530	11 01	C1
06 07 075 000	90 50	XX	07 07 554 800	21 40	03	08 54 355 600	90 20	XX	08 55 752 300	76 01	XX	74 00 462 767	11 01	01
06 07 075 100	90 50	XX	07 07 554 800	21 60	03	08 54 410 000	12 45	C2	08 55 775 000	90 55	XX	77 00 268 014	11 30	01
06 07 081 400	90 50	XX	08 02 114 200	90 40	XX	08 54 411 200	90 50	XX	08 55 811 700	50 40	16	77 00 268 027	12 01	C1
06 07 107 900	37 01	01	08 02 114 200	90 40	01	08 54 437 000	87 30	01	08 55 829 500	50 60	04	77 00 268 054	16 30	01
06 07 107 900	37 10	01	08 02 114 200	90 40	02	08 54 522 400	12 45	C1	08 55 843 900	50 55	XX	77 00 268 055	16 30	01
06 07 110 200	38 C1	01	08 02 614 900	12 45	01	08 54 592 002	38 30	08	08 55 893 400	50 55	XX	77 00 268 075	10 70	01
06 07 110 500	38 C1	01	08 02 614 900	12 45	02	08 54 625 200	12 45	C1	08 55 898 600	87 30	XX	77 00 268 099	13 50	01
06 07 823 100	90 50	XX	08 21 175 500	97 01	01	08 54 690 700	57 01	C1	08 55 947 200	80 01	01	77 00 268 105	13 90	01
06 07 944 600	68 C1	02	08 22 969 600	97 01	01	08 54 690 700	57 10	01	08 55 960 200	41 30	C2	77 00 268 109	10 60	01
06 07 950 500	76 C1	01	08 24 450 500	21 20	01	08 54 690 700	58 01	C1	08 55 960 200	46 10	01	77 00 268 110	13 50	01
06 08 044 500	90 50	XX	08 51 182 500	19 01	06	08 54 698 300	90 50	XX	08 55 960 200	46 10	02	77 00 268 111	16 10	C1
06 08 084 000	32 40	C2	08 51 955 100	50 01	02	08 54 698 400	90 50	XX	08 55 960 200	46 10	C3	77 00 268 135	10 50	C1
06 08 094 100	34 10	C8	08 52 174 300	17 01	01	08 54 725 300	17 01	C2	08 57 533 400	58 30	12	77 00 268 139	11 01	C1
06 08 107 100	37 C1	01	08 52 397 900	21 60	04	08 54 725 300	17 01	C3	08 70 010 800	16 16	01	77 00 268 142	10 50	C1
06 08 107 500	37 C1	01	08 52 457 800	58 30	02	08 54 725 400	17 01	C1	08 70 010 800	16 16	XX	77 00 268 143	10 50	01
06 08 107 500	37 10	01	08 52 851 900	50 10	02	08 54 761 902	21 20	C3	08 70 012 700	37 20	01	77 00 268 150	10 50	C1
06 08 119 400	68 C1	02	08 52 851 900	50 15	02	08 54 761 902	21 20	06	08 70 012 800	37 20	01	77 00 268 151	10 50	01
06 08 180 800	90 50	XX	08 52 851 900	50 20	02	08 54 766 500	57 01	02	10 89 020 200	37 70	01	77 00 268 154	10 50	01
06 08 187 600	90 50	XX	08 52 851 900	50 25	02	08 54 766 500	57 10	C2	10 89 020 200	37 30	C1	77 00 268 158	10 60	C1
06 08 229 300	37 30	01	08 52 888 002	23 20	02	08 54 769 200	90 55	XX	10 89 030 352	33 40	02	77 00 268 165	11 01	C1
06 08 232 000	33 40	02	08 52 888 002	23 30	13	08 54 769 300	90 55	XX	50 00 080 365	50 55	XX	77 00 268 168	10 60	01
06 08 307 400	55 10	02	08 52 888 102	21 20	32	08 54 769 500	76 01	XX	50 00 080 845	84 30	C1	77 00 268 172	17 10	C1

1	2	3	1	2	3	1	2	3	1	2	3	1	2	3
77 00 268 173	11 C1	C1	77 CC 516 029	90 55	XX	77 00 534 746	36 20	01	77 CC 551 769	55 20	C2	77 00 560 788	37 80	02
77 00 268 176	11 01	01	77 00 516 029	90 55	01	77 00 535 252	77 10	12	77 CC 551 952	21 50	C1	77 00 560 788	37 80	04
77 00 268 183	12 30	C1	77 CC 516 031	71 10	10	77 00 537 295	90 35	XX	77 CC 551 952	21 40	C1	77 CC 560 788	37 50	C2
77 00 268 186	11 C1	01	77 CC 516 675	19 01	01	77 00 539 258	83 10	01	77 CC 551 955	21 40	C1	77 CC 560 788	37 50	04
77 00 268 188	13 30	01	77 00 517 130	52 C1	02	77 00 539 476	37 80	15	77 CC 551 965	21 40	C1	77 00 560 988	21 40	C1
77 00 268 190	13 30	C1	77 CC 517 545	84 20	01	77 00 539 807	86 20	C1	77 CC 551 971	21 40	C1	77 00 561 013	21 60	01
77 00 268 192	13 30	C1	77 CC 517 551	90 55	XX	77 00 539 825	29 01	C2	77 CC 552 136	38 C1	01	77 CC 561 274	31 40	02
77 00 268 215	11 C1	01	77 CC 518 330	88 20	XX	77 00 540 075	88 20	XX	77 CC 552 227	34 10	02	77 CC 561 335	21 60	C1
77 00 268 219	12 50	C1	77 CC 518 387	36 20	XX	77 00 540 076	88 20	XX	77 CC 552 220	32 10	02	77 CC 561 367	31 40	C2
77 00 268 220	13 30	01	77 CC 518 389	36 20	01	77 00 541 380	21 50	01	77 CC 552 848	21 60	C1	77 CC 561 463	38 20	01
77 00 268 221	13 30	C1	77 CC 518 588	61 01	01	77 00 541 381	21 50	C2	77 CC 552 949	21 60	C1	77 CC 561 464	38 20	C1
77 00 268 222	13 30	C1	77 CC 518 585	61 C1	01	77 00 541 447	21 50	XX	77 CC 552 952	21 20	01	77 CC 561 738	29 01	01
77 00 268 224	16 16	01	77 CC 518 596	19 30	01	77 00 541 448	21 50	XX	77 CC 553 000	21 60	C1	77 CC 561 763	31 C1	C2
77 00 268 227	13 50	01	77 CC 518 764	84 20	04	77 00 541 465	21 30	C2	77 CC 553 003	21 60	C1	77 CC 562 056	21 60	01
77 00 268 231	12 C1	C1	77 CC 518 874	77 10	02	77 00 541 481	50 30	C2	77 CC 553 118	21 40	C1	77 CC 562 058	21 40	C1
77 00 268 232	16 30	01	77 00 518 874	78 10	01	77 00 541 521	21 60	C2	77 CC 553 118	21 60	01	77 CC 563 341	33 40	02
77 00 268 249	13 20	01	77 00 518 874	78 10	02	77 00 541 570	21 50	C4	77 CC 553 600	55 20	C4	77 CC 563 385	19 80	C4
77 00 268 250	12 50	C1	77 00 518 984	88 20	XX	77 00 541 609	21 40	C1	77 CC 554 186	50 55	XX	77 CC 563 409	19 80	02
77 00 268 251	13 50	01	77 CC 519 655	90 30	02	77 00 541 617	21 50	C1	77 CC 555 262	21 60	01	77 CC 563 410	19 80	02
77 00 268 273	13 30	01	77 CC 519 773	90 15	02	77 00 541 890	21 40	C1	77 CC 555 344	61 C1	C1	77 CC 563 822	87 50	C1
77 00 268 275	16 20	01	77 CC 519 994	78 10	10	77 00 541 891	21 40	C1	77 CC 555 345	61 C1	C1	77 CC 563 836	21 20	01
77 00 268 292	12 70	01	77 CC 520 251	84 20	04	77 00 541 970	21 50	C1	77 CC 555 380	61 C1	C1	77 CC 563 836	23 20	02
77 00 268 293	13 50	01	77 CC 520 265	88 20	01	77 00 542 059	21 40	C2	77 CC 555 381	61 C1	C1	77 CC 563 969	36 20	01
77 00 268 296	13 50	01	77 CC 520 337	34 10	08	77 00 542 163	21 40	C2	77 CC 555 382	68 20	XX	77 CC 563 984	41 20	C1
77 00 500 011	32 40	C2	77 CC 520 357	90 15	02	77 00 542 286	10 70	C1	77 CC 555 383	68 20	XX	77 CC 563 985	41 20	C1
77 00 501 280	84 20	01	77 CC 521 180	83 10	01	77 00 542 806	90 55	XX	77 CC 555 458	88 20	XX	77 CC 564 260	36 20	01
77 00 501 607	90 10	XX	77 00 521 230	15 30	01	77 00 542 824	88 20	XX	77 CC 555 628	21 60	C1	77 CC 564 311	83 10	01
77 00 502 547	33 40	C2	77 CC 521 415	88 20	01	77 00 542 953	90 55	XX	77 CC 555 907	21 40	C1	77 00 564 346	41 10	01
77 00 502 811	88 20	XX	77 00 522 332	66 C1	02	77 00 543 147	90 20	C2	77 CC 555 944	21 60	C1	77 00 564 347	41 10	01
77 00 502 812	50 55	XX	77 CC 523 486	80 01	01	77 00 544 419	83 01	C5	77 CC 555 945	21 60	01	77 CC 564 463	37 30	01
77 00 503 558	12 70	C1	77 CC 523 786	61 10	04	77 00 544 546	21 50	C1	77 CC 556 152	10 70	C1	77 00 564 533	21 20	C1
77 00 508 926	90 10	XX	77 CC 523 787	61 10	04	77 00 544 686	16 30	C1	77 CC 556 436	23 40	C2	77 CC 564 533	23 20	C2
77 00 509 023	50 55	XX	77 00 523 857	90 15	02	77 00 544 807	86 20	C1	77 CC 557 065	21 50	C2	77 CC 565 050	41 20	C1
77 00 509 087	36 20	01	77 00 528 391	38 01	01	77 00 545 679	38 01	C1	77 CC 557 071	21 40	C1	77 CC 565 051	41 20	C1
77 00 509 236	36 20	XX	77 CC 528 392	38 C1	01	77 00 546 059	32 01	C1	77 CC 557 072	21 40	C1	77 CC 565 564	44 20	01
77 00 509 237	36 20	XX	77 CC 528 393	38 01	01	77 00 546 413	69 01	C4	77 CC 557 117	21 60	C1	77 CC 565 779	21 30	C1
77 00 509 238	36 20	XX	77 CC 532 135	19 30	01	77 00 546 729	21 50	XX	77 CC 557 179	21 50	C1	77 CC 565 780	21 30	C1
77 00 509 239	36 20	XX	77 CC 532 727	35 01	16	77 00 546 731	21 50	XX	77 CC 557 321	21 20	C1	77 CC 565 822	90 55	XX
77 00 509 240	36 20	XX	77 00 533 030	61 10	02	77 00 547 406	86 20	C1	77 CC 557 845	21 30	C1	77 CC 565 823	90 55	XX
77 00 509 620	90 50	XX	77 00 533 144	52 20	01	77 00 548 562	36 20	C1	77 CC 557 972	50 55	XX	77 CC 565 940	19 80	02
77 00 510 349	60 20	03	77 CC 533 145	76 01	XX	77 00 549 188	50 15	01	77 CC 558 327	15 20	C1	77 CC 565 953	61 30	01
77 00 510 350	60 20	06	77 00 533 146	76 01	XX	77 00 550 238	16 30	01	77 CC 558 650	21 40	C1	77 00 565 955	61 30	C1
77 00 511 332	36 20	01	77 CC 533 220	52 20	01	77 00 550 847	55 20	C2	77 CC 559 525	76 C1	C1	77 CC 565 962	50 10	C2
77 00 511 771	90 50	XX	77 00 533 226	76 01	01	77 00 550 847	55 20	12	77 CC 560 057	21 20	01	77 00 565 962	50 15	02
77 00 511 874	87 50	C1	77 00 534 202	52 20	02	77 00 550 847	58 30	12	77 CC 560 057	22 20	C1	77 CC 565 962	50 20	02
77 00 511 899	86 20	01	77 00 534 203	52 20	01	77 00 550 912	50 01	06	77 CC 560 121	38 20	01	77 CC 565 962	50 25	C2
77 00 512 226	15 50	01	77 00 534 204	52 20	01	77 00 551 527	61 30	C1	77 CC 560 125	38 20	01	77 CC 566 023	41 30	01
77 00 515 140	90 35	XX	77 00 534 208	52 20	01	77 00 551 530	61 30	C1	77 CC 560 211	38 20	C1	77 CC 566 257	41 20	01

77 00 566 264

- 3 -

77 CC 572 484

1	2	3	1	2	3	1	2	3	1	2	3	1	2	3
77 00 566 264	36 20	C1	77 CC 568 429	36 20	01	77 00 568 956	32 30	C2	77 CC 570 518	37 70	C1	77 00 571 754	50 C1	02
77 00 566 327	43 C1	01	77 CC 568 430	36 20	01	77 00 569 001	60 50	C1	77 CC 570 520	37 70	C1	77 00 571 755	50 01	XX
77 00 566 332	41 30	C2	77 CC 568 440	33 C1	02	77 00 569 033	38 C1	C1	77 CC 570 521	37 70	C1	77 CC 571 756	50 C1	YY
77 00 566 357	45 C1	01	77 00 568 441	34 10	02	77 00 569 103	13 80	01	77 CC 570 615	19 50	C2	77 CC 571 765	19 60	01
77 00 566 481	42 C1	01	77 CC 568 444	32 10	02	77 00 569 127	19 60	01	77 CC 570 615	19 60	04	77 CC 571 795	64 C1	C1
77 CC 566 483	43 C1	C1	77 CC 568 445	34 10	02	77 00 569 221	41 20	01	77 CC 570 527	65 C1	C2	77 00 571 756	65 C1	C1
77 CC 566 643	19 C1	C2	77 CC 568 446	33 01	02	77 00 569 223	41 30	01	77 CC 571 062	60 20	01	77 CC 571 828	69 C1	01
77 00 566 656	19 C1	02	77 00 568 456	33 01	02	77 00 569 307	43 01	01	77 CC 571 090	37 C1	C1	77 CC 571 833	42 C1	01
77 CC 566 711	43 C1	C1	77 CC 568 455	33 01	02	77 00 569 308	42 01	C1	77 CC 571 090	37 10	C1	77 CC 571 834	42 C1	C1
77 00 566 712	43 C1	01	77 CC 568 519	13 80	01	77 00 569 311	43 01	C1	77 CC 571 178	50 C1	C2	77 CC 571 854	42 C1	01
77 CC 566 723	19 C1	02	77 00 568 521	36 20	01	77 00 569 312	43 01	C1	77 CC 571 181	50 C1	XX	77 CC 571 855	42 C1	C1
77 CC 566 854	34 10	C2	77 CC 568 522	13 80	01	77 00 569 313	42 01	C1	77 CC 571 182	50 C1	XX	77 CC 571 933	76 C1	01
77 00 566 855	34 10	02	77 CC 568 541	33 01	01	77 00 569 314	42 01	C1	77 CC 571 185	50 C1	01	77 00 571 934	38 C1	01
77 00 566 868	32 C1	01	77 CC 568 543	33 C1	01	77 00 569 329	54 01	C1	77 CC 571 187	50 C1	C1	77 CC 571 982	50 50	C2
77 CC 566 872	32 C1	C1	77 CC 568 554	34 01	02	77 00 569 340	31 01	C2	77 CC 571 189	50 C1	C2	77 CC 571 952	50 50	C2
77 00 566 927	34 10	02	77 00 568 567	38 01	01	77 00 569 442	33 01	C1	77 CC 571 201	61 10	C2	77 CC 571 953	50 40	C2
77 00 566 935	45 C1	01	77 00 568 568	31 01	02	77 00 569 444	33 C1	C1	77 CC 571 205	52 20	C1	77 CC 571 953	50 50	C2
77 CC 566 939	32 10	04	77 CC 568 581	41 10	01	77 00 569 483	43 01	C1	77 CC 571 208	52 20	C1	77 CC 571 955	50 50	C2
77 00 566 941	37 70	C2	77 00 568 582	41 10	01	77 00 569 484	43 01	C1	77 CC 571 209	52 20	XX	77 CC 571 958	50 50	C2
77 00 567 020	19 80	C2	77 00 568 584	46 10	01	77 00 569 492	52 01	C2	77 CC 571 210	52 20	XX	77 CC 572 031	19 01	C1
77 00 567 137	37 10	C1	77 00 568 622	31 01	02	77 00 569 493	52 01	C1	77 CC 571 219	44 C1	C1	77 00 572 178	31 C1	C2
77 00 567 206	43 C1	01	77 00 568 624	31 01	02	77 00 569 494	52 01	C1	77 CC 571 315	36 20	01	77 CC 572 179	31 C1	C2
77 00 567 207	43 C1	01	77 00 568 652	61 C1	01	77 00 569 495	31 01	C2	77 CC 571 320	61 10	C1	77 CC 572 180	31 01	04
77 00 567 224	32 C1	01	77 00 568 658	36 20	01	77 00 569 517	32 10	C2	77 CC 571 331	61 10	C1	77 CC 572 182	33 C1	C2
77 00 567 325	37 70	01	77 00 568 659	36 20	01	77 00 569 545	60 20	03	77 CC 571 332	61 10	C1	77 00 572 183	33 C1	C2
77 00 567 326	37 70	C1	77 CC 568 660	36 20	01	77 00 569 546	60 20	C3	77 CC 571 333	61 10	C1	77 00 572 184	33 C1	02
77 00 567 454	42 10	01	77 CC 568 701	41 10	01	77 00 569 547	60 20	01	77 CC 571 335	60 20	01	77 CC 572 185	33 C1	01
77 00 567 464	31 40	01	77 CC 568 703	41 10	01	77 00 569 597	17 01	02	77 CC 571 369	61 30	C1	77 00 572 203	38 C1	C1
77 00 567 465	31 40	C1	77 00 568 752	66 01	01	77 00 569 601	33 C1	C2	77 CC 571 372	21 40	C1	77 00 572 204	38 C1	C1
77 00 567 541	45 C1	C1	77 00 568 755	54 01	01	77 00 569 833	45 01	C1	77 CC 571 373	21 40	01	77 00 572 228	61 30	01
77 00 567 580	31 C1	01	77 00 568 760	54 01	01	77 00 569 851	38 01	01	77 CC 571 375	21 40	01	77 CC 572 231	50 25	04
77 00 567 581	31 C1	C1	77 CC 568 761	36 20	01	77 00 569 938	66 01	01	77 CC 571 377	21 40	01	77 CC 572 232	50 40	02
77 00 567 662	31 40	02	77 00 568 804	42 10	01	77 00 570 000	19 01	01	77 CC 571 378	21 40	01	77 00 572 232	50 50	C2
77 00 567 698	42 10	01	77 CC 568 811	32 10	01	77 00 570 001	19 01	C1	77 CC 571 381	44 C1	01	77 CC 572 233	50 15	C2
77 CC 567 908	31 C1	C2	77 CC 568 861	36 20	01	77 00 570 066	42 10	01	77 CC 571 437	52 20	C2	77 CC 572 233	50 25	02
77 00 567 986	43 C1	01	77 00 568 861	36 30	01	77 00 570 068	42 10	C1	77 CC 571 456	61 10	C2	77 CC 572 236	16 30	C1
77 CC 567 989	43 01	01	77 00 568 862	36 30	01	77 00 570 069	53 01	C2	77 CC 571 582	34 C1	C1	77 CC 572 306	50 70	C2
77 00 568 053	41 20	01	77 CC 568 892	38 01	01	77 00 570 091	23 30	01	77 CC 571 573	13 50	C2	77 CC 572 323	33 C1	08
77 00 568 205	31 C1	02	77 00 568 901	66 01	02	77 00 570 200	54 C1	C1	77 CC 571 582	38 C1	01	77 00 572 331	64 C1	C2
77 00 568 268	31 01	C2	77 CC 568 902	66 01	02	77 00 570 201	54 C1	C1	77 CC 571 600	52 20	C1	77 CC 572 372	38 C1	01
77 CC 568 280	29 C1	C1	77 00 568 903	66 01	02	77 00 570 204	43 01	C1	77 CC 571 684	50 C1	C1	77 CC 572 427	76 C1	01
77 00 568 331	36 20	02	77 CC 568 904	66 01	02	77 00 570 206	43 C1	01	77 00 571 686	50 C1	01	77 CC 572 435	55 20	C1
77 00 568 351	41 20	01	77 00 568 905	66 01	02	77 00 570 223	46 01	01	77 CC 571 744	42 C1	01	77 CC 572 455	50 01	XX
77 CC 568 353	41 20	01	77 CC 568 932	54 01	01	77 00 570 224	46 C1	01	77 CC 571 745	42 C1	01	77 00 572 456	50 C1	03
77 00 568 366	42 10	C1	77 CC 568 933	54 01	01	77 00 570 241	42 10	C1	77 CC 571 746	42 C1	C1	77 CC 572 457	50 C1	02
77 00 568 406	41 20	01	77 CC 568 951	31 40	02	77 00 570 243	42 10	01	77 CC 571 747	42 C1	01	77 CC 572 481	55 20	01
77 00 568 407	41 20	01	77 CC 568 952	31 40	01	77 00 570 276	60 20	01	77 CC 571 748	41 10	C1	77 CC 572 483	55 20	C1
77 00 568 408	41 20	C1	77 CC 568 954	31 40	01	77 00 570 296	61 10	02	77 CC 571 749	41 10	C1	77 00 572 484	55 20	01

1	2	3	1	2	3	1	2	3	1	2	3	1	2	3
77 00 572 485	55 20	01	77 CC 573 515	41 30	02	77 00 574 919	52 20	C1	77 00 576 55C	58 30	C1	77 CC 578 52E	19 80	C1
77 00 572 486	55 20	01	77 00 573 516	41 30	02	77 00 574 938	46 10	01	77 00 576 551	58 30	C1	77 00 578 559	36 20	01
77 00 572 491	33 40	C2	77 00 573 565	37 20	01	77 00 574 959	37 30	C1	77 00 576 553	66 C1	C1	77 CC 578 621	34 30	C2
77 00 572 704	68 C1	01	77 00 573 57E	76 01	01	77 00 575 042	42 10	01	77 00 576 554	66 C1	01	77 CC 578 739	37 10	01
77 00 572 836	50 20	02	77 00 573 596	84 20	01	77 00 575 066	61 10	C1	77 00 576 632	15 C1	C1	77 CC 578 764	34 10	C1
77 00 572 836	50 25	02	77 00 573 597	84 20	01	77 00 575 136	77 10	02	77 00 576 632	15 C1	C1	77 00 578 615	37 10	01
77 00 572 838	50 10	01	77 00 573 55E	84 20	02	77 00 575 136	78 10	02	77 00 576 72E	87 C1	C1	77 CC 578 551	19 50	C1
77 00 572 838	50 15	02	77 00 573 60C	84 20	01	77 00 575 176	23 20	C1	77 00 576 72E	87 30	C1	77 00 578 954	19 50	C1
77 00 572 851	61 10	01	77 00 573 666	76 01	01	77 00 575 196	80 01	C1	77 00 576 72E	87 30	02	77 00 578 956	43 C1	C1
77 00 572 884	83 10	01	77 00 573 711	75 01	04	77 00 575 249	37 20	01	77 00 576 82E	65 C1	C1	77 00 579 022	41 20	01
77 00 572 886	66 C1	C2	77 00 573 713	36 20	01	77 00 575 263	84 01	01	77 00 576 841	58 30	C1	77 00 579 058	19 60	01
77 00 572 866	15 80	C2	77 00 573 714	75 01	08	77 00 575 264	84 C1	C1	77 00 576 864	10 50	C1	77 00 579 059	77 10	04
77 00 573 028	37 C1	02	77 00 573 715	37 30	01	77 00 575 266	84 01	01	77 00 576 50C	57 30	C1	77 00 579 100	77 10	02
77 00 573 028	37 10	C1	77 00 573 73E	60 20	01	77 00 575 267	84 01	01	77 00 576 501	57 20	C1	77 00 579 240	38 20	01
77 00 573 028	37 10	02	77 00 573 737	60 20	01	77 00 575 417	21 50	C1	77 00 576 511	38 20	C2	77 00 579 308	19 60	01
77 00 573 030	37 C1	02	77 00 573 75C	37 30	01	77 00 575 418	21 50	C1	77 00 576 54E	10 60	C7	77 00 579 311	19 C1	C1
77 00 573 030	37 10	C1	77 00 573 805	50 70	02	77 00 575 438	56 40	C1	77 00 577 010	17 C1	C1	77 00 579 361	46 10	01
77 00 573 030	37 10	02	77 00 573 863	83 01	01	77 00 575 465	38 20	C2	77 00 577 05E	87 C1	C1	77 00 579 369	46 10	01
77 00 573 031	50 30	01	77 00 573 875	57 01	01	77 00 575 493	34 01	C1	77 00 577 05E	87 C1	01	77 00 579 437	43 C1	C1
77 00 573 032	50 30	01	77 00 573 875	57 10	01	77 00 575 503	35 01	C1	77 00 577 08E	58 C1	C1	77 00 579 438	43 C1	C1
77 00 573 033	50 30	01	77 00 573 88C	57 01	01	77 00 575 506	21 50	C1	77 00 577 127	87 50	C1	77 00 579 544	69 C1	01
77 00 573 034	50 30	01	77 00 573 88C	57 10	01	77 00 575 519	50 60	C2	77 00 577 153	58 40	C2	77 00 579 545	69 C1	01
77 00 573 049	36 20	01	77 00 574 041	66 C1	01	77 00 575 520	50 60	C1	77 00 577 15E	37 10	01	77 00 579 787	19 50	C1
77 00 573 052	59 C1	01	77 00 574 042	66 C1	02	77 00 575 521	50 60	01	77 00 577 16C	37 10	C1	77 00 579 801	23 20	C1
77 00 573 063	55 20	01	77 00 574 056	68 C1	01	77 00 575 529	20 01	C1	77 00 577 26E	46 10	C1	77 00 579 803	23 20	C1
77 00 573 064	55 20	01	77 00 574 054	58 01	01	77 00 575 540	56 10	C1	77 00 577 270	46 10	01	77 00 579 822	41 30	C1
77 00 573 065	55 20	C1	77 00 574 115	77 01	02	77 00 575 614	84 20	C1	77 00 577 474	50 15	C2	77 00 579 849	72 C1	02
77 00 573 066	55 20	C1	77 00 574 130	77 01	02	77 00 575 635	87 30	C1	77 00 577 542	38 20	C1	77 00 579 850	72 01	01
77 00 573 067	55 20	C1	77 00 574 136	58 30	01	77 00 575 659	50 70	C1	77 00 577 701	41 30	C1	77 00 579 851	72 C1	01
77 00 573 068	55 20	01	77 00 574 150	87 40	01	77 00 575 660	50 70	C1	77 00 577 707	50 15	C1	77 00 579 898	57 C1	C1
77 00 573 069	55 20	C1	77 00 574 186	76 C1	01	77 00 575 775	76 01	C2	77 00 577 707	50 15	C2	77 00 579 899	57 10	C1
77 00 573 070	55 20	C1	77 00 574 206	33 01	04	77 00 575 843	57 01	C1	77 00 577 707	50 25	C1	77 00 579 900	90 15	02
77 00 573 071	55 20	C1	77 00 574 207	31 C1	04	77 00 575 844	57 10	C1	77 00 577 707	50 25	C2	77 00 579 929	41 30	01
77 00 573 072	55 20	C1	77 00 574 235	64 C1	02	77 00 575 871	87 01	C1	77 00 577 73E	87 30	C1	77 00 579 938	38 30	01
77 00 573 078	50 30	01	77 00 574 262	78 01	01	77 00 575 974	71 10	02	77 00 577 954	38 20	C1	77 00 579 988	38 30	C1
77 00 573 079	50 30	01	77 00 574 263	78 01	01	77 00 575 975	71 10	02	77 00 578 041	88 20	01	77 00 579 995	36 30	C1
77 00 573 091	32 10	02	77 00 574 30E	31 40	02	77 00 575 997	87 50	C1	77 00 578 13E	61 C1	01	77 00 580 029	19 50	C1
77 00 573 114	68 C1	01	77 00 574 365	46 10	01	77 00 576 003	33 40	C2	77 00 578 15E	52 20	C1	77 00 580 065	37 01	01
77 00 573 115	68 C1	C1	77 00 574 45E	68 01	02	77 00 576 006	71 10	01	77 00 578 16C	52 20	C1	77 00 580 071	37 C1	C1
77 00 573 128	61 10	C1	77 00 574 45E	68 01	04	77 00 576 007	71 10	01	77 00 578 16E	52 20	01	77 00 580 077	72 01	02
77 00 573 129	61 10	01	77 00 574 585	76 01	02	77 00 576 008	71 10	02	77 00 578 277	58 C1	01	77 00 580 078	72 01	C2
77 00 573 228	33 C1	02	77 00 574 64E	58 30	01	77 00 576 027	86 01	C1	77 00 578 32E	41 10	C1	77 00 580 112	77 10	04
77 00 573 258	41 10	01	77 00 574 685	55 20	01	77 00 576 146	61 01	01	77 00 578 32E	84 30	C1	77 00 580 112	78 10	02
77 00 573 286	83 10	01	77 00 574 685	66 01	01	77 00 576 330	38 30	C1	77 00 578 33E	64 C1	01	77 00 580 152	76 01	01
77 00 573 322	41 30	01	77 00 574 690	55 20	01	77 00 576 330	38 30	C2	77 00 578 33E	64 C1	C1	77 00 580 211	55 20	01
77 00 573 379	45 C1	03	77 00 574 690	66 01	01	77 00 576 364	38 30	01	77 00 578 42E	87 30	C1	77 00 580 212	55 20	01
77 00 573 452	75 C1	01	77 00 574 776	41 10	01	77 00 576 470	87 30	01	77 00 578 42E	87 30	C1	77 00 580 217	38 30	01
77 00 573 453	75 C1	01	77 00 574 917	52 20	01	77 00 576 589	54 01	C1	77 00 578 52E	15 80	C1	77 00 580 218	38 30	C1

1	2	3	1	2	3	1	2	3	1	2	3	1	2	3
77 00 580 234	38 30	01	77 00 581 564	76 01	01	77 00 584 323	19 50	C2	77 00 586 233	37 40	C1	77 00 587 445	19 01	C1
77 00 580 248	38 30	04	77 00 581 572	23 40	07	77 00 584 325	38 01	01	77 00 586 441	68 01	04	77 00 587 459	55 10	02
77 00 580 262	38 30	C1	77 00 581 673	37 50	01	77 00 584 332	71 01	C1	77 00 586 442	68 01	C1	77 00 587 453	36 20	C1
77 00 580 263	38 30	01	77 00 581 892	38 01	XX	77 00 584 333	71 01	C1	77 00 586 461	55 20	02	77 00 587 495	36 20	01
77 00 580 270	38 30	01	77 00 581 893	35 01	05	77 00 584 340	71 01	C1	77 00 586 465	87 50	C1	77 00 587 497	38 01	XX
77 00 580 297	38 30	01	77 00 581 990	31 01	02	77 00 584 341	71 01	01	77 00 586 538	55 20	01	77 00 587 607	19 40	01
77 00 580 314	38 30	01	77 00 581 993	71 10	02	77 00 584 559	55 01	C2	77 00 586 535	55 20	C1	77 00 587 608	19 40	01
77 00 580 315	38 30	01	77 00 582 003	53 01	01	77 00 584 600	38 01	C1	77 00 586 608	55 01	C1	77 00 587 662	38 20	C1
77 00 580 324	10 50	C1	77 00 582 004	52 20	01	77 00 584 640	66 01	C1	77 00 586 605	55 01	C1	77 00 587 676	61 30	C3
77 00 580 374	87 40	01	77 00 582 065	74 01	01	77 00 584 641	66 01	C1	77 00 586 614	58 01	C1	77 00 587 853	81 40	01
77 00 580 376	23 20	01	77 00 582 066	74 01	01	77 00 584 760	37 80	C3	77 00 586 615	19 40	C1	77 00 587 880	19 40	C1
77 00 580 375	65 01	C2	77 00 582 067	74 01	01	77 00 584 775	84 01	C1	77 00 586 616	19 40	C1	77 00 587 881	19 40	01
77 00 580 388	52 20	01	77 00 582 068	74 01	01	77 00 584 878	13 80	C1	77 00 586 625	87 30	01	77 00 587 885	19 40	01
77 00 580 571	19 30	01	77 00 582 270	37 20	01	77 00 584 988	69 01	C1	77 00 586 635	87 30	C2	77 00 587 886	19 40	C1
77 00 580 595	78 10	01	77 00 582 271	37 01	01	77 00 585 010	84 01	C1	77 00 586 725	65 01	01	77 00 587 953	21 30	C1
77 00 580 596	78 10	01	77 00 582 273	37 01	01	77 00 585 018	87 30	C1	77 00 586 726	65 01	C1	77 00 588 056	38 30	C1
77 00 580 597	76 01	01	77 00 582 362	37 20	01	77 00 585 346	23 30	C1	77 00 586 727	65 01	C1	77 00 588 078	21 60	C1
77 00 580 669	76 01	02	77 00 582 501	37 01	01	77 00 585 432	19 01	C1	77 00 586 728	65 01	C1	77 00 588 083	38 20	01
77 00 580 771	78 01	01	77 00 582 534	19 80	01	77 00 585 547	58 01	C2	77 00 586 816	55 20	01	77 00 588 152	37 70	01
77 00 580 800	23 20	01	77 00 582 535	19 80	01	77 00 585 549	58 01	C1	77 00 586 817	55 20	C1	77 00 588 218	65 01	02
77 00 580 831	72 01	02	77 00 582 617	53 01	01	77 00 585 550	84 10	01	77 00 587 072	36 20	01	77 00 588 219	65 01	01
77 00 580 833	38 30	02	77 00 582 618	53 01	01	77 00 585 557	54 01	C1	77 00 587 074	36 20	01	77 00 588 220	65 01	01
77 00 580 880	68 01	01	77 00 582 700	87 01	01	77 00 585 562	37 80	C2	77 00 587 110	64 01	02	77 00 588 221	65 01	02
77 00 580 867	44 20	01	77 00 582 704	37 60	01	77 00 585 562	37 90	C2	77 00 587 165	19 20	C1	77 00 588 222	65 01	01
77 00 580 977	37 20	01	77 00 582 929	75 01	02	77 00 585 596	68 01	01	77 00 587 276	65 01	01	77 00 588 223	65 01	01
77 00 580 990	19 80	02	77 00 582 930	75 01	02	77 00 585 603	19 20	C1	77 00 587 277	65 01	C1	77 00 588 224	65 01	02
77 00 581 189	19 80	01	77 00 582 934	84 20	01	77 00 585 605	46 10	01	77 00 587 278	65 01	C1	77 00 588 225	65 01	01
77 00 581 192	19 80	01	77 00 583 111	81 40	01	77 00 585 640	19 20	03	77 00 587 279	65 01	01	77 00 588 226	65 01	C1
77 00 581 240	54 01	C1	77 00 583 357	31 01	02	77 00 585 645	90 25	XX	77 00 587 305	71 01	01	77 00 588 227	65 01	02
77 00 581 241	54 01	01	77 00 583 849	38 30	02	77 00 585 717	87 50	C1	77 00 587 306	71 01	01	77 00 588 228	65 01	01
77 00 581 242	54 01	01	77 00 583 917	75 01	02	77 00 585 732	66 01	C1	77 00 587 321	61 10	C1	77 00 588 229	65 01	C1
77 00 581 244	54 01	C1	77 00 583 936	47 01	01	77 00 585 736	38 20	01	77 00 587 322	61 10	01	77 00 588 230	65 01	02
77 00 581 245	54 01	01	77 00 583 937	47 01	01	77 00 585 740	23 20	C1	77 00 587 327	50 20	01	77 00 588 231	65 01	C1
77 00 581 290	56 40	01	77 00 583 942	47 01	01	77 00 585 741	23 20	C1	77 00 587 337	50 25	C1	77 00 588 232	65 01	01
77 00 581 345	52 20	XX	77 00 583 945	47 01	01	77 00 585 769	84 10	01	77 00 587 338	50 10	01	77 00 588 249	79 01	04
77 00 581 346	52 20	XX	77 00 584 033	37 01	01	77 00 585 816	84 20	01	77 00 587 338	50 15	01	77 00 588 268	90 25	C1
77 00 581 360	78 01	01	77 00 584 035	37 01	01	77 00 586 154	71 10	C2	77 00 587 338	50 20	C1	77 00 588 330	55 01	C2
77 00 581 374	38 01	01	77 00 584 044	60 20	01	77 00 586 168	23 20	02	77 00 587 338	50 25	C1	77 00 588 613	38 30	C1
77 00 581 377	75 01	02	77 00 584 118	84 01	01	77 00 586 194	50 20	01	77 00 587 335	50 10	01	77 00 588 617	19 01	C1
77 00 581 426	50 15	01	77 00 584 115	84 01	01	77 00 586 195	50 20	01	77 00 587 335	50 15	C1	77 00 588 618	19 01	C1
77 00 581 427	50 15	01	77 00 584 120	19 50	01	77 00 586 196	50 25	01	77 00 587 335	50 20	01	77 00 588 684	23 40	01
77 00 581 447	76 01	01	77 00 584 130	65 01	02	77 00 586 197	50 25	01	77 00 587 335	50 25	C1	77 00 588 687	21 60	01
77 00 581 461	55 20	02	77 00 584 190	71 01	01	77 00 586 198	50 10	01	77 00 587 340	50 10	C1	77 00 588 685	20 01	C1
77 00 581 490	76 01	02	77 00 584 264	75 01	02	77 00 586 199	50 10	C1	77 00 587 340	50 15	C1	77 00 588 777	38 20	01
77 00 581 501	54 01	01	77 00 584 265	75 01	02	77 00 586 200	50 15	01	77 00 587 340	50 20	01	77 00 588 864	80 20	C1
77 00 581 502	54 01	01	77 00 584 293	84 20	01	77 00 586 201	50 15	C1	77 00 587 340	50 25	C1	77 00 588 876	37 30	01
77 00 581 524	21 30	01	77 00 584 294	85 01	01	77 00 586 213	71 10	C1	77 00 587 426	55 01	18	77 00 588 878	37 30	C1
77 00 581 525	76 01	02	77 00 584 294	85 10	01	77 00 586 214	71 10	C1	77 00 587 426	55 10	18	77 00 588 881	87 50	C1

77 00 588 892

- 6 -

77 00 613 458

1	2	3	1	2	3	1	2	3	1	2	3	1	2	3
77 00 588 892	37 20	C1	77 00 590 991	69 01	01	77 00 591 833	37 80	C1	77 00 611 050	57 50	C1	77 00 611 561	68 01	01
77 00 589 030	81 40	01	77 00 591 210	37 60	01	77 00 591 835	37 80	C1	77 00 611 052	55 01	C1	77 00 611 562	68 01	01
77 00 589 089	71 10	01	77 00 591 272	19 20	01	77 00 591 837	37 80	C1	77 00 611 071	57 01	C2	77 00 611 605	50 40	C2
77 00 589 200	32 01	01	77 00 591 273	19 20	01	77 00 591 880	38 30	C1	77 00 611 071	57 10	02	77 00 611 605	50 50	C2
77 00 589 201	32 01	01	77 00 591 274	19 20	01	77 00 610 156	72 01	C1	77 00 611 099	52 10	04	77 00 611 608	58 40	C1
77 00 589 290	23 40	01	77 00 591 275	19 20	01	77 00 610 157	72 01	C1	77 00 611 100	32 10	C4	77 00 611 609	58 40	01
77 00 589 321	55 01	C1	77 00 591 480	71 01	01	77 00 610 158	72 01	C1	77 00 611 185	55 20	01	77 00 611 610	58 40	01
77 00 589 322	55 01	02	77 00 591 481	71 01	01	77 00 610 159	72 01	C1	77 00 611 211	66 01	01	77 00 611 611	58 40	01
77 00 589 323	55 10	01	77 00 591 482	71 01	01	77 00 610 160	72 01	C1	77 00 611 212	66 01	C1	77 00 611 638	71 10	C1
77 00 589 324	55 10	02	77 00 591 483	71 01	01	77 00 610 161	72 01	C1	77 00 611 219	55 20	C1	77 00 611 639	71 10	01
77 00 589 325	55 01	C2	77 00 591 484	71 01	01	77 00 610 162	72 01	C1	77 00 611 219	56 30	C1	77 00 611 983	71 01	C1
77 00 589 325	55 10	02	77 00 591 485	71 01	01	77 00 610 163	72 01	C1	77 00 611 228	55 20	C1	77 00 612 042	79 01	C4
77 00 589 362	50 00	02	77 00 591 486	71 01	01	77 00 610 187	66 01	01	77 00 611 229	55 20	01	77 00 612 043	79 01	C4
77 00 589 461	83 10	C1	77 00 591 487	71 01	01	77 00 610 232	38 01	C1	77 00 611 230	55 20	01	77 00 612 044	75 01	C4
77 00 589 466	13 80	01	77 00 591 488	71 01	01	77 00 610 254	75 01	C2	77 00 611 231	55 20	C1	77 00 612 045	79 01	C4
77 00 589 471	41 10	C1	77 00 591 489	71 01	01	77 00 610 324	37 80	C1	77 00 611 232	55 20	01	77 00 612 052	68 01	01
77 00 589 494	61 01	02	77 00 591 490	71 01	01	77 00 610 326	37 80	C1	77 00 611 233	55 20	01	77 00 612 053	68 01	01
77 00 589 745	56 01	01	77 00 591 491	71 01	01	77 00 610 328	37 80	C2	77 00 611 234	55 20	01	77 00 612 056	68 01	01
77 00 590 050	37 30	01	77 00 591 492	71 01	01	77 00 610 337	72 01	C1	77 00 611 235	55 20	01	77 00 612 057	68 01	01
77 00 590 051	37 01	01	77 00 591 492	71 10	01	77 00 610 338	72 01	01	77 00 611 236	55 20	C1	77 00 612 180	19 30	C1
77 00 590 052	37 01	01	77 00 591 493	71 10	01	77 00 610 339	72 01	C1	77 00 611 237	55 20	C1	77 00 612 189	37 70	01
77 00 590 065	37 30	01	77 00 591 494	71 10	01	77 00 610 340	72 01	C1	77 00 611 238	55 20	C1	77 00 612 191	59 20	01
77 00 590 178	61 10	01	77 00 591 495	71 10	01	77 00 610 341	72 01	C1	77 00 611 239	55 20	01	77 00 612 192	59 20	01
77 00 590 179	61 10	C1	77 00 591 496	71 10	01	77 00 610 342	72 01	C1	77 00 611 305	66 01	C1	77 00 612 450	66 01	01
77 00 590 190	66 01	01	77 00 591 497	71 10	01	77 00 610 343	72 01	C1	77 00 611 324	15 00	02	77 00 612 451	66 01	C1
77 00 590 306	71 01	01	77 00 591 511	77 10	01	77 00 610 344	72 01	C1	77 00 611 325	15 00	02	77 00 612 505	75 01	02
77 00 590 361	87 50	C1	77 00 591 512	77 10	01	77 00 610 430	36 30	C1	77 00 611 416	66 01	C1	77 00 612 608	55 20	01
77 00 590 370	21 20	02	77 00 591 515	77 10	01	77 00 610 431	36 30	01	77 00 611 417	66 01	01	77 00 612 609	55 20	01
77 00 590 421	85 01	C2	77 00 591 516	77 10	01	77 00 610 432	36 30	01	77 00 611 418	66 01	C1	77 00 612 610	55 20	01
77 00 590 421	85 10	C2	77 00 591 519	77 10	01	77 00 610 433	36 30	01	77 00 611 419	66 01	C1	77 00 612 611	55 20	01
77 00 590 611	55 20	C1	77 00 591 520	77 10	01	77 00 610 528	58 01	C1	77 00 611 425	55 01	C1	77 00 612 658	50 01	XX
77 00 590 612	55 20	C1	77 00 591 523	77 10	01	77 00 610 530	58 01	C1	77 00 611 457	61 30	C1	77 00 612 659	50 01	XX
77 00 590 613	55 20	C1	77 00 591 524	77 10	01	77 00 610 531	58 01	C1	77 00 611 470	15 50	C1	77 00 612 666	58 20	01
77 00 590 639	65 01	01	77 00 591 693	16 30	01	77 00 610 532	37 80	C2	77 00 611 471	15 50	01	77 00 612 857	19 30	C1
77 00 590 641	65 01	01	77 00 591 725	16 30	01	77 00 610 608	23 20	C1	77 00 611 474	74 01	C1	77 00 612 899	19 30	C1
77 00 590 643	65 01	01	77 00 591 761	58 30	01	77 00 610 609	23 20	C1	77 00 611 475	74 01	01	77 00 612 996	52 20	01
77 00 590 780	58 30	01	77 00 591 762	58 30	01	77 00 610 761	58 40	C2	77 00 611 476	74 01	C1	77 00 613 001	52 20	C1
77 00 590 781	58 30	01	77 00 591 763	58 30	01	77 00 610 817	87 30	XX	77 00 611 477	74 01	C1	77 00 613 052	34 01	01
77 00 590 782	58 30	01	77 00 591 764	58 30	01	77 00 610 845	37 20	01	77 00 611 478	74 01	01	77 00 613 066	55 20	01
77 00 590 783	58 30	01	77 00 591 765	58 30	01	77 00 610 854	81 40	C1	77 00 611 479	74 01	01	77 00 613 088	55 20	01
77 00 590 784	58 30	01	77 00 591 766	58 30	01	77 00 610 864	87 50	C1	77 00 611 481	74 01	C1	77 00 613 069	55 20	01
77 00 590 785	58 30	01	77 00 591 767	58 30	01	77 00 610 911	59 01	01	77 00 611 482	74 01	01	77 00 613 072	55 20	01
77 00 590 786	58 30	01	77 00 591 768	58 30	01	77 00 610 989	64 01	C2	77 00 611 484	74 01	01	77 00 613 073	55 20	01
77 00 590 787	58 30	01	77 00 591 799	58 01	01	77 00 610 994	61 30	C1	77 00 611 485	74 01	01	77 00 613 077	55 20	01
77 00 590 826	58 20	01	77 00 591 800	58 01	01	77 00 610 995	61 30	C1	77 00 611 486	74 01	01	77 00 613 237	77 10	12
77 00 590 988	65 01	01	77 00 591 805	58 01	01	77 00 610 996	61 30	C1	77 00 611 540	71 10	01	77 00 613 238	77 10	12
77 00 590 989	65 01	C1	77 00 591 825	37 80	01	77 00 610 997	61 30	C1	77 00 611 544	59 01	C1	77 00 613 458	50 40	XX
77 00 590 990	65 01	01	77 00 591 827	37 80	01	77 00 610 998	66 01	01	77 00 611 548	71 10	C1	77 00 613 458	50 50	C1

1	2	3	1	2	3	1	2	3	1	2	3	1	2	3
77 00 613 459	50 25	04	77 00 615 241	58 C1	01	77 01 004 828	35 01	C1	77 C1 C18 C75	16 16	C1	77 C1 C18 446	50 15	C1
77 00 613 460	50 70	02	77 00 615 242	58 01	01	77 01 005 398	84 30	01	77 01 018 C75	16 16	01	77 01 018 447	50 10	01
77 00 613 450	61 30	02	77 00 615 247	57 01	01	77 01 005 613	81 40	C1	77 C1 C18 1C4	80 20	01	77 C1 C18 447	50 15	01
77 00 613 851	61 30	01	77 00 615 247	57 10	01	77 01 006 203	37 60	01	77 C1 018 138	53 C1	03	77 C1 C18 447	50 20	C1
77 00 613 930	38 20	01	77 00 615 254	57 01	01	77 01 006 838	16 16	C1	77 C1 018 135	53 C1	03	77 01 018 447	50 25	C1
77 00 613 978	72 C1	01	77 00 615 254	57 10	01	77 01 006 890	16 16	01	77 C1 018 140	53 C1	xx	77 C1 018 465	50 20	C1
77 00 613 879	72 C1	01	77 00 615 261	57 01	01	77 01 007 160	16 16	C1	77 C1 C18 141	53 C1	C2	77 C1 C18 465	50 25	01
77 00 613 980	72 C1	01	77 00 615 261	57 10	01	77 01 007 161	16 16	01	77 C1 018 142	53 C1	03	77 01 018 470	50 20	01
77 00 613 981	72 C1	01	77 00 615 264	58 C1	01	77 01 007 933	87 01	C1	77 C1 018 143	53 C1	03	77 01 018 470	50 25	01
77 00 613 982	72 C1	01	77 00 615 265	58 C1	01	77 01 008 752	12 45	01	77 C1 018 144	53 C1	C2	77 C1 C18 471	50 20	C1
77 00 613 983	72 C1	01	77 00 615 345	61 C1	01	77 01 009 301	34 20	C1	77 C1 018 145	53 01	xx	77 C1 018 471	50 25	01
77 00 613 984	72 C1	01	77 00 615 369	58 30	01	77 01 009 302	34 30	01	77 C1 018 225	84 10	01	77 C1 018 503	58 01	02
77 00 613 985	72 C1	01	77 00 615 370	58 30	01	77 01 010 158	56 20	C1	77 C1 018 226	84 10	02	77 01 018 513	56 20	01
77 00 613 988	72 C1	01	77 00 615 375	57 01	01	77 01 010 287	34 30	C1	77 C1 018 227	84 10	02	77 C1 018 515	80 30	C1
77 00 613 989	72 C1	01	77 00 615 378	57 01	01	77 01 010 552	16 20	01	77 01 018 283	85 20	01	77 01 018 516	80 30	C1
77 00 613 990	72 C1	C1	77 00 615 381	57 C1	01	77 01 010 578	34 30	C2	77 C1 018 284	85 20	01	77 01 018 517	80 30	C1
77 00 613 991	72 C1	01	77 00 615 384	61 01	01	77 01 012 228	16 20	01	77 01 018 285	85 20	01	77 01 018 518	80 30	01
77 00 613 992	72 C1	01	77 00 615 396	58 30	01	77 01 012 232	16 20	C1	77 C1 C18 286	85 20	01	77 01 018 519	80 30	C1
77 00 613 993	72 C1	01	77 00 615 461	57 10	01	77 01 012 236	16 20	01	77 01 018 287	85 20	01	77 01 018 520	82 01	02
77 00 613 994	72 C1	01	77 00 615 464	57 10	01	77 01 012 240	16 20	01	77 C1 018 325	85 01	02	77 01 018 521	82 01	C2
77 00 613 995	72 C1	01	77 00 615 467	57 10	01	77 01 012 451	17 01	C1	77 C1 018 325	85 10	02	77 01 018 575	81 20	01
77 00 614 081	19 40	C1	77 00 615 918	79 C1	02	77 01 012 547	83 01	C4	77 C1 C18 326	85 01	02	77 01 018 576	13 80	01
77 00 614 082	19 40	01	77 00 615 919	79 C1	02	77 01 012 655	37 20	C1	77 C1 018 326	85 10	02	77 01 018 577	13 80	01
77 00 614 162	19 30	01	77 00 615 920	79 01	02	77 01 013 143	37 60	01	77 C1 C18 327	85 01	C1	77 C1 018 578	13 80	C2
77 00 614 585	58 40	01	77 00 615 921	79 C1	02	77 01 013 275	29 01	01	77 C1 018 325	80 10	01	77 C1 018 579	13 80	01
77 00 614 586	58 40	01	77 00 615 922	79 01	02	77 01 013 502	12 35	C2	77 01 018 326	80 10	01	77 C1 018 580	13 80	C1
77 00 614 587	58 40	01	77 00 615 925	79 01	02	77 01 013 533	12 45	C1	77 01 018 327	80 10	01	77 C1 018 581	13 80	C1
77 00 614 588	58 40	C1	77 00 615 926	79 01	02	77 01 014 128	16 10	01	77 C1 C18 328	80 10	C1	77 01 018 582	13 80	02
77 00 614 589	58 40	01	77 01 000 115	80 01	01	77 01 016 085	75 01	C8	77 C1 018 325	80 10	01	77 01 018 583	13 80	C1
77 00 614 590	58 40	01	77 01 000 921	12 45	06	77 01 016 511	86 01	C2	77 C1 C18 340	80 10	C1	77 C1 018 584	83 01	C1
77 00 614 591	58 40	01	77 C1 000 953	59 20	02	77 01 016 512	86 01	xx	77 C1 C18 341	80 20	C1	77 01 018 585	83 01	C1
77 00 614 592	58 40	01	77 01 000 954	59 20	04	77 01 016 717	85 20	01	77 01 018 345	50 60	01	77 01 018 586	83 01	01
77 00 614 593	58 40	01	77 01 000 955	59 20	02	77 01 017 100	34 30	01	77 C1 018 346	50 60	C1	77 C1 C18 587	83 01	01
77 00 614 594	58 40	01	77 01 000 957	59 20	02	77 01 017 105	84 30	01	77 C1 018 347	50 60	C1	77 01 018 588	83 01	01
77 00 614 595	58 40	01	77 01 000 964	59 20	02	77 01 017 305	16 20	01	77 C1 C18 348	50 60	01	77 01 018 589	83 01	01
77 00 614 596	58 40	01	77 01 001 445	34 30	02	77 01 017 306	16 20	01	77 C1 C18 361	85 20	C1	77 C1 018 590	83 01	C1
77 00 614 655	66 C1	01	77 C1 001 447	32 30	02	77 01 017 307	16 20	C1	77 C1 018 364	85 10	01	77 01 018 591	83 01	01
77 00 614 660	66 C1	01	77 C1 001 447	34 30	02	77 01 017 697	29 01	xx	77 C1 018 365	85 10	01	77 01 018 592	83 01	01
77 00 614 703	33 40	02	77 01 001 560	37 60	01	77 01 017 750	86 01	01	77 C1 C18 425	81 10	01	77 01 018 593	83 01	01
77 00 614 952	52 20	01	77 C1 001 561	37 60	01	77 01 017 755	86 01	01	77 01 018 430	81 10	01	77 C1 C18 594	83 01	01
77 00 615 155	61 30	03	77 01 001 790	16 20	01	77 01 017 790	32 30	01	77 01 018 431	81 10	01	77 01 018 595	83 01	C1
77 00 615 156	61 10	01	77 C1 002 227	13 C1	01	77 01 017 791	32 30	C1	77 C1 018 432	81 10	01	77 01 018 596	83 01	01
77 00 615 157	61 10	01	77 C1 002 952	86 01	01	77 01 017 795	17 01	C1	77 01 018 433	81 10	C1	77 01 018 597	83 01	01
77 00 615 203	61 10	01	77 01 003 660	12 35	01	77 01 017 823	90 55	xx	77 01 018 443	50 10	01	77 C1 C18 598	83 01	01
77 00 615 204	61 10	01	77 C1 003 722	84 10	02	77 01 017 938	50 15	01	77 C1 018 443	50 15	01	77 01 018 599	83 01	02
77 00 615 205	61 10	01	77 C1 003 723	84 10	01	77 01 017 938	50 25	01	77 C1 018 444	50 25	01	77 C1 C18 600	83 01	02
77 00 615 235	58 C1	01	77 C1 004 823	35 C1	01	77 01 017 939	50 15	01	77 01 018 445	50 25	C1	77 01 018 601	83 01	02
77 00 615 240	58 C1	01	77 C1 004 826	35 C1	01	77 01 017 939	50 25	01	77 C1 018 446	50 10	C1	77 01 018 606	13 20	01

77 01 018 607

- 8 -

77 01 458 516

1	2	3	1	2	3	1	2	3	1	2	3	1	2	3	1	2	3
77 01 018 607	13 20	01	77 01 018 741	61 30	01	77 01 200 344	16 20	01	77 01 200 553	34 30	01	77 01 458 301	29 01	01			
77 01 018 628	50 60	01	77 01 018 742	61 30	01	77 01 200 353	60 20	01	77 01 200 554	34 30	01	77 01 458 302	33 01	02			
77 01 018 650	24 30	01	77 01 018 755	61 30	03	77 01 200 416	16 16	01	77 01 200 555	34 30	01	77 01 458 308	48 01	01			
77 01 018 651	84 30	01	77 01 018 756	75 01	01	77 01 200 418	16 16	01	77 01 200 556	34 30	01	77 01 458 312	36 01	01			
77 01 018 655	16 16	01	77 01 018 757	75 01	04	77 01 200 423	16 20	01	77 01 200 557	37 20	01	77 01 458 313	36 01	01			
77 01 018 656	16 16	01	77 01 018 758	75 01	04	77 01 200 431	20 01	01	77 01 200 558	37 20	01	77 01 458 314	36 01	01			
77 01 018 657	16 16	01	77 01 018 759	75 01	02	77 01 200 449	85 01	01	77 01 200 559	32 30	01	77 01 458 315	36 01	01			
77 01 018 658	16 16	01	77 01 018 760	75 01	02	77 01 200 449	85 10	01	77 01 348 015	50 60	02	77 01 458 330	21 30	01			
77 01 018 659	16 16	01	77 01 018 763	75 01	01	77 01 200 457	85 01	01	77 01 348 016	50 60	02	77 01 458 331	21 50	01			
77 01 018 660	16 16	01	77 01 018 765	16 20	01	77 01 200 458	85 01	01	77 01 348 019	50 60	01	77 01 458 336	21 50	01			
77 01 018 662	16 10	01	77 01 018 766	16 20	01	77 01 200 459	85 01	01	77 01 348 020	50 60	01	77 01 458 336	23 20	01			
77 01 018 663	16 10	01	77 01 018 767	16 20	01	77 01 200 460	85 01	01	77 01 348 020	50 60	02	77 01 458 385	50 40	01			
77 01 018 664	16 10	01	77 01 018 768	16 20	01	77 01 200 461	85 10	01	77 01 348 026	50 60	01	77 01 458 389	50 50	01			
77 01 018 665	16 10	01	77 01 018 769	16 20	01	77 01 200 462	85 10	01	77 01 348 036	50 60	xx	77 01 458 390	50 40	01			
77 01 018 666	16 10	01	77 01 018 770	16 20	01	77 01 200 463	85 10	01	77 01 348 044	57 01	01	77 01 458 390	50 50	01			
77 01 018 667	16 10	01	77 01 018 771	16 20	01	77 01 200 464	85 10	01	77 01 348 053	50 60	01	77 01 458 391	50 40	01			
77 01 018 668	16 10	01	77 01 018 772	16 20	01	77 01 200 514	13 80	01	77 01 348 062	50 60	02	77 01 458 391	50 50	01			
77 01 018 690	57 30	01	77 01 018 773	16 20	01	77 01 200 515	13 80	01	77 01 348 064	50 60	06	77 01 458 392	50 40	01			
77 01 018 697	12 10	01	77 01 018 774	58 20	01	77 01 200 516	13 80	01	77 01 348 064	50 60	xx	77 01 458 392	50 50	01			
77 01 018 698	12 10	01	77 01 018 784	32 30	02	77 01 200 517	83 01	01	77 01 348 064	50 60	01	77 01 458 395	55 01	01			
77 01 018 699	12 10	01	77 01 018 785	32 30	02	77 01 200 519	34 01	01	77 01 365 300	51 40	01	77 01 458 396	55 10	01			
77 01 018 700	12 15	01	77 01 018 786	32 30	02	77 01 200 520	34 01	01	77 01 365 305	51 40	01	77 01 458 397	55 01	01			
77 01 018 701	12 45	01	77 01 018 785	80 10	01	77 01 200 521	90 60	01	77 01 365 342	52 01	01	77 01 458 398	71 01	01			
77 01 018 702	12 45	01	77 01 018 785	80 10	02	77 01 200 522	16 10	01	77 01 365 344	52 01	01	77 01 458 399	71 01	01			
77 01 018 703	12 45	01	77 01 018 790	80 10	02	77 01 200 523	16 10	01	77 01 365 345	51 40	01	77 01 458 417	41 10	01			
77 01 018 704	12 45	06	77 01 018 791	80 10	02	77 01 200 525	16 16	01	77 01 365 348	57 30	01	77 01 458 418	41 10	01			
77 01 018 705	12 15	01	77 01 018 792	80 10	01	77 01 200 526	16 16	01	77 01 365 348	51 20	01	77 01 458 419	41 10	01			
77 01 018 706	12 45	02	77 01 018 793	80 10	01	77 01 200 527	16 10	01	77 01 365 350	51 40	01	77 01 458 420	41 10	01			
77 01 018 707	12 35	01	77 01 018 794	80 10	01	77 01 200 528	16 10	01	77 01 365 351	51 40	01	77 01 458 421	41 10	01			
77 01 018 708	12 45	01	77 01 018 794	80 10	02	77 01 200 536	85 01	02	77 01 365 356	36 40	01	77 01 458 422	41 20	01			
77 01 018 709	12 45	01	77 01 018 815	80 10	01	77 01 200 539	85 10	02	77 01 400 538	50 01	01	77 01 458 423	41 10	01			
77 01 018 710	12 15	01	77 01 018 816	80 10	01	77 01 200 559	37 60	01	77 01 400 624	50 01	01	77 01 458 424	41 30	01			
77 01 018 711	12 45	04	77 01 018 817	80 10	01	77 01 200 561	17 01	01	77 01 458 255	21 20	01	77 01 458 425	41 30	01			
77 01 018 712	12 15	01	77 01 018 818	80 10	01	77 01 200 562	17 01	01	77 01 458 260	31 30	02	77 01 458 426	41 30	01			
77 01 018 722	32 30	01	77 01 018 819	80 10	01	77 01 200 563	17 01	01	77 01 458 261	31 30	02	77 01 458 427	41 30	01			
77 01 018 723	17 01	01	77 01 018 820	80 10	01	77 01 200 564	17 01	01	77 01 458 262	32 10	02	77 01 458 428	55 10	01			
77 01 018 724	17 01	01	77 01 018 830	60 50	01	77 01 200 571	16 20	01	77 01 458 263	31 01	02	77 01 458 429	55 10	01			
77 01 018 725	17 01	01	77 01 018 831	60 50	01	77 01 200 572	16 20	01	77 01 458 264	31 01	02	77 01 458 431	40 01	01			
77 01 018 726	17 01	01	77 01 018 837	57 30	01	77 01 200 575	32 30	01	77 01 458 265	34 10	02	77 01 458 432	40 01	01			
77 01 018 727	17 01	01	77 01 018 842	52 20	01	77 01 200 576	32 30	01	77 01 458 266	33 01	02	77 01 458 433	40 01	01			
77 01 018 728	17 01	01	77 01 018 849	34 30	01	77 01 200 577	32 30	01	77 01 458 267	37 80	04	77 01 458 434	40 01	01			
77 01 018 729	17 01	02	77 01 018 850	34 30	01	77 01 200 578	32 30	01	77 01 458 267	37 50	04	77 01 458 435	40 01	01			
77 01 018 735	61 30	01	77 01 200 216	85 01	01	77 01 200 579	32 30	01	77 01 458 268	37 80	02	77 01 458 436	40 01	01			
77 01 018 736	61 30	01	77 01 200 216	85 10	01	77 01 200 588	34 30	01	77 01 458 268	37 50	02	77 01 458 437	40 01	01			
77 01 018 737	61 30	01	77 01 200 217	85 20	01	77 01 200 589	34 30	01	77 01 458 269	19 50	01	77 01 458 438	40 01	01			
77 01 018 738	61 30	01	77 01 200 267	16 10	01	77 01 200 590	34 30	01	77 01 458 269	31 01	02	77 01 458 450	23 01	01			
77 01 018 739	61 30	06	77 01 200 305	86 01	01	77 01 200 591	34 30	01	77 01 458 295	31 01	02	77 01 458 515	74 01	01			
77 01 018 740	61 30	01	77 01 200 330	85 20	01	77 01 200 592	34 30	01	77 01 458 300	29 01	01	77 01 458 516	74 01	01			

1	2	3	1	2	3	1	2	3	1	2	3	1	2	3
77 01 458 517	74 C1	01	77 01 458 732	78 10	01	77 03 001 008	87 01	02	77 03 001 042	12 C1	04	77 03 001 202	13 90	01
77 01 458 518	74 C1	01	77 01 458 745	78 10	01	77 03 001 009	12 70	01	77 03 001 042	12 90	01	77 03 001 244	21 30	08
77 01 458 530	79 C1	01	77 01 458 746	78 10	01	77 03 001 018	10 70	C3	77 03 001 044	11 C1	02	77 03 001 320	57 01	02
77 01 458 531	79 C1	01	77 01 458 747	78 10	01	77 03 001 018	31 40	04	77 03 001 045	11 40	01	77 03 001 320	57 10	02
77 01 458 532	79 C1	01	77 01 458 760	77 10	01	77 03 001 018	33 40	04	77 03 001 052	19 80	02	77 03 001 320	76 C1	02
77 01 458 533	79 C1	C1	77 01 458 761	77 10	01	77 03 001 020	11 20	C2	77 03 001 052	19 80	04	77 03 001 337	55 10	02
77 01 458 545	77 10	01	77 01 458 762	77 10	01	77 03 001 020	16 10	02	77 03 001 052	22 C1	C2	77 03 001 347	16 30	C1
77 01 458 546	77 10	01	77 01 458 775	77 10	01	77 03 001 020	45 01	06	77 03 001 054	11 20	04	77 03 001 350	55 C1	C4
77 01 458 547	77 10	C1	77 01 458 776	77 10	01	77 03 001 021	11 30	04	77 03 001 054	19 30	05	77 03 001 353	19 30	C1
77 01 458 548	77 10	01	77 01 458 777	77 10	01	77 03 001 022	19 01	C1	77 03 001 054	19 50	01	77 03 001 362	21 30	04
77 01 458 560	77 10	01	77 01 458 800	78 10	01	77 03 001 022	41 30	02	77 03 001 054	19 80	C2	77 03 001 363	21 20	C1
77 01 458 561	77 10	01	77 01 458 801	78 10	01	77 03 001 022	46 10	C1	77 03 001 054	19 80	06	77 03 001 373	16 30	03
77 01 458 562	77 10	01	77 01 458 802	78 10	01	77 03 001 022	85 01	03	77 03 001 055	12 30	01	77 03 001 380	36 20	02
77 01 458 563	77 10	01	77 01 458 811	10 01	01	77 03 001 022	85 10	03	77 03 001 055	12 80	C1	77 03 001 399	31 40	06
77 01 458 575	77 10	01	77 01 458 814	10 01	01	77 03 001 024	19 01	01	77 03 001 059	11 C1	03	77 03 001 431	21 20	01
77 01 458 576	77 10	01	77 01 458 826	23 01	01	77 03 001 024	19 01	04	77 03 001 064	10 50	12	77 03 001 431	21 30	C4
77 01 458 577	77 10	01	77 01 516 248	87 50	01	77 03 001 024	46 10	C2	77 03 001 065	37 C1	C1	77 03 001 431	23 20	C4
77 01 458 578	77 10	C1	77 01 518 800	21 01	01	77 03 001 024	46 10	03	77 03 001 065	37 10	01	77 03 001 447	57 01	C1
77 01 458 600	77 10	01	77 01 519 383	43 01	01	77 03 001 024	75 01	04	77 03 001 075	52 C1	C2	77 03 001 447	57 10	01
77 01 458 601	77 10	01	77 01 519 384	43 01	01	77 03 001 027	11 01	04	77 03 001 077	19 80	C2	77 03 001 491	10 50	23
77 01 458 602	77 10	01	77 01 519 387	44 01	01	77 03 001 027	11 20	C4	77 03 001 077	41 30	02	77 03 001 491	10 70	C3
77 01 458 603	77 10	01	77 01 519 388	44 01	01	77 03 001 027	76 01	02	77 03 001 051	13 80	C1	77 03 001 497	34 30	C4
77 01 458 615	78 10	01	77 01 519 795	42 10	01	77 03 001 029	75 01	C4	77 03 001 105	36 20	01	77 03 001 501	33 40	06
77 01 458 616	78 10	01	77 01 531 703	43 01	01	77 03 001 034	13 30	02	77 03 001 122	37 70	02	77 03 001 552	16 30	03
77 01 458 617	78 10	01	77 01 531 705	44 01	01	77 03 001 034	23 20	01	77 03 001 125	25 C1	01	77 03 001 584	21 20	10
77 01 458 618	78 10	01	77 01 531 708	43 01	01	77 03 001 035	11 01	C1	77 03 001 125	25 C1	03	77 03 001 596	33 40	08
77 01 458 630	78 10	01	77 01 531 710	44 01	01	77 03 001 035	12 45	C2	77 03 001 125	25 10	01	77 03 001 622	16 30	01
77 01 458 631	78 10	01	77 01 532 785	47 01	01	77 03 001 035	12 70	C2	77 03 001 125	25 10	03	77 03 001 624	11 30	01
77 01 458 632	78 10	01	77 01 532 792	47 01	01	77 03 001 037	10 50	01	77 03 001 138	21 20	02	77 03 001 637	33 01	02
77 01 458 633	78 10	01	77 01 533 081	47 01	01	77 03 001 037	11 40	C2	77 03 001 138	23 20	02	77 03 001 643	21 20	01
77 01 458 645	78 10	01	77 01 533 082	47 01	01	77 03 001 037	12 70	01	77 03 001 140	38 20	02	77 03 001 644	21 20	13
77 01 458 646	78 10	01	77 01 533 087	48 01	01	77 03 001 037	16 30	C1	77 03 001 140	67 50	C2	77 03 001 645	21 20	C2
77 01 458 647	78 10	01	77 01 534 978	42 10	01	77 03 001 037	23 20	02	77 03 001 142	16 30	01	77 03 001 646	21 20	04
77 01 458 648	78 10	01	77 01 534 975	42 10	01	77 03 001 037	23 30	13	77 03 001 145	36 30	02	77 03 001 647	21 20	C1
77 01 458 660	74 C1	01	77 01 535 043	40 10	01	77 03 001 037	37 70	02	77 03 001 165	28 20	01	77 03 001 647	23 20	02
77 01 458 661	74 C1	C1	77 01 982 845	88 01	01	77 03 001 037	37 70	04	77 03 001 172	36 20	04	77 03 001 648	21 20	01
77 01 458 662	74 C1	01	77 01 982 846	88 01	01	77 03 001 037	38 30	02	77 03 001 174	15 50	01	77 03 001 649	21 20	C1
77 01 458 675	79 C1	01	77 01 982 853	88 C1	01	77 03 001 038	21 30	06	77 03 001 174	15 80	04	77 03 001 650	12 70	01
77 01 458 676	79 C1	01	77 01 982 897	88 01	01	77 03 001 038	38 01	C2	77 03 001 180	22 40	03	77 03 001 658	86 20	01
77 01 458 677	79 C1	01	77 01 982 895	88 01	01	77 03 001 038	87 50	02	77 03 001 182	13 90	C2	77 03 001 661	33 01	C4
77 01 458 700	77 10	01	77 01 982 913	88 01	01	77 03 001 039	10 70	04	77 03 001 185	12 50	03	77 03 001 662	13 80	C2
77 01 458 701	77 10	01	77 01 982 915	88 01	01	77 03 001 039	11 01	C4	77 03 001 185	31 40	12	77 03 001 663	13 80	C1
77 01 458 702	77 10	01	77 01 982 918	88 01	01	77 03 001 039	11 40	C6	77 03 001 187	15 80	04	77 03 001 668	50 15	C2
77 01 458 715	77 10	C1	77 01 982 925	88 01	01	77 03 001 039	37 20	02	77 03 001 187	31 C1	C2	77 03 001 668	50 15	04
77 01 458 716	77 10	01	77 01 982 930	88 01	01	77 03 001 039	38 30	02	77 03 001 192	12 50	02	77 03 001 668	50 25	C2
77 01 458 717	77 10	01	77 03 001 001	61 30	06	77 03 001 040	11 01	02	77 03 001 192	23 C1	02	77 03 001 668	50 25	04
77 01 458 730	78 10	01	77 03 001 001	84 10	01	77 03 001 042	10 50	C2	77 03 001 192	23 C1	04	77 03 001 674	41 10	C4
77 01 458 731	78 10	01	77 03 001 007	33 40	02	77 03 001 042	11 40	18	77 03 001 196	41 10	C1	77 03 001 684	61 10	02

1	2	3	1	2	3	1	2	3	1	2	3	1	2	3
77 03 001 684	61 10	04	77 03 C16 C22	16 30	02	77 03 019 040	55 01	02	77 03 044 C1E	15 01	02	77 03 055 C1C	20 01	06
77 03 001 701	61 10	02	77 03 C16 C22	61 10	04	77 03 019 040	55 10	02	77 03 044 C24	85 01	01	77 03 055 C11	13 80	01
77 03 001 703	61 01	01	77 03 C16 C22	66 01	01	77 03 019 041	55 10	02	77 03 044 C24	85 01	02	77 03 055 C11	16 30	03
77 03 001 712	61 10	04	77 03 C16 C22	68 01	08	77 03 027 048	12 01	02	77 03 044 C24	85 10	01	77 03 055 C11	19 50	03
77 03 001 761	52 20	02	77 03 C16 C24	86 01	02	77 03 027 060	11 20	02	77 03 044 C24	85 10	02	77 03 055 C11	19 60	04
77 03 003 002	21 50	09	77 03 C16 C25	19 01	02	77 03 032 007	41 10	04	77 03 044 C25	15 01	01	77 03 055 C11	32 10	04
77 03 004 067	84 01	01	77 03 C16 C25	61 10	04	77 03 032 013	21 20	16	77 03 046 C07	46 01	08	77 03 055 C11	34 10	04
77 03 004 067	84 01	02	77 03 C16 C40	37 30	02	77 03 032 035	21 20	02	77 03 046 C07	46 10	03	77 03 055 C11	36 20	01
77 03 004 073	50 10	06	77 03 C16 C51	71 01	12	77 03 034 003	32 10	02	77 03 046 012	46 01	18	77 03 055 C11	37 01	04
77 03 004 073	50 20	06	77 03 C16 C51	71 10	02	77 03 034 008	37 70	02	77 03 046 C25	77 10	04	77 03 055 C11	37 10	04
77 03 004 073	50 25	06	77 03 C16 C55	58 30	02	77 03 034 009	36 30	02	77 03 046 C31	15 50	04	77 03 055 C12	31 40	12
77 03 004 080	50 01	03	77 03 C16 C67	58 40	01	77 03 034 011	36 20	01	77 03 046 C31	41 10	06	77 03 055 C13	13 80	03
77 03 004 082	50 10	04	77 03 C16 C67	58 40	06	77 03 034 011	37 01	01	77 03 046 C34	58 01	02	77 03 055 C15	13 90	01
77 03 004 082	50 20	04	77 03 C16 C75	84 01	04	77 03 034 011	37 10	01	77 03 046 C35	58 30	02	77 03 055 019	33 40	06
77 03 004 082	50 25	04	77 03 C16 C7E	58 30	02	77 03 034 012	13 80	01	77 03 050 C05	52 20	01	77 03 056 C06	21 20	01
77 03 005 021	50 20	02	77 03 C16 C7E	71 01	08	77 03 034 012	19 80	04	77 03 050 C10	58 01	01	77 03 056 C06	23 20	02
77 03 005 037	50 30	04	77 03 C16 C05	55 20	02	77 03 034 012	31 01	02	77 03 052 015	31 01	02	77 03 056 C11	16 30	01
77 03 007 002	81 40	01	77 03 C16 C23	71 01	04	77 03 034 013	33 01	02	77 03 052 C27	15 01	02	77 03 056 C12	85 01	02
77 03 007 005	87 40	02	77 03 C16 C32	66 01	01	77 03 034 013	33 01	04	77 03 052 C30	85 01	05	77 03 056 C12	85 10	02
77 03 007 007	57 30	03	77 03 C16 C35	61 10	04	77 03 034 013	33 01	08	77 03 052 C30	85 10	05	77 03 056 C19	19 30	01
77 03 007 007	84 20	01	77 03 C16 C44	19 50	04	77 03 034 013	34 01	01	77 03 052 C32	11 01	04	77 03 056 C26	10 50	23
77 03 007 012	84 01	04	77 03 C16 C44	41 10	06	77 03 034 013	36 20	01	77 03 052 C35	11 30	04	77 03 056 C35	52 20	02
77 03 007 013	84 01	01	77 03 C16 C44	46 01	08	77 03 034 013	36 30	02	77 03 052 C36	38 20	02	77 03 056 C35	52 20	04
77 03 007 013	85 01	02	77 03 C16 C44	46 01	18	77 03 034 014	31 30	04	77 03 052 C36	38 30	04	77 03 057 C02	13 90	02
77 03 007 013	85 10	02	77 03 C16 C44	46 10	03	77 03 034 015	33 01	02	77 03 052 C37	38 20	04	77 03 057 C02	13 50	03
77 03 007 013	86 20	02	77 03 C16 C55	55 20	02	77 03 034 016	31 30	02	77 03 052 C66	16 30	01	77 03 057 C02	23 40	03
77 03 007 039	50 40	08	77 03 C16 C55	55 20	12	77 03 034 021	31 01	02	77 03 052 C66	15 80	04	77 03 057 C08	21 60	01
77 03 007 039	72 01	02	77 03 C16 C65	53 40	02	77 03 034 026	36 20	01	77 03 052 071	32 01	08	77 03 057 C09	38 20	01
77 03 007 055	72 01	04	77 03 C16 C65	50 50	XX	77 03 034 C30	36 20	01	77 03 052 112	16 30	01	77 03 057 C12	59 20	02
77 03 007 055	75 01	08	77 03 C16 C7E	81 20	02	77 03 034 C33	32 10	02	77 03 052 113	21 60	01	77 03 058 C06	21 20	02
77 03 007 105	50 30	02	77 03 C16 C84	80 30	06	77 03 034 C44	38 20	04	77 03 052 11E	21 40	01	77 03 058 C06	23 20	02
77 03 007 109	50 30	02	77 03 C16 C86	71 01	08	77 03 034 C46	19 80	04	77 03 052 119	21 40	01	77 03 058 C07	23 20	04
77 03 007 117	50 30	02	77 03 C16 C87	87 01	08	77 03 034 C46	36 20	02	77 03 052 120	21 40	01	77 03 058 C08	16 30	03
77 03 007 123	61 30	02	77 03 C16 C93	55 20	04	77 03 034 C47	19 80	02	77 03 052 121	21 40	01	77 03 058 C08	21 20	11
77 03 009 064	11 01	05	77 03 C16 C93	66 01	03	77 03 034 C47	33 01	04	77 03 052 122	21 40	01	77 03 058 C08	38 20	01
77 03 009 065	10 40	05	77 03 C16 C9E	46 10	12	77 03 034 C47	34 10	02	77 03 052 124	36 20	02	77 03 058 C09	21 40	01
77 03 009 069	20 01	06	77 03 C16 C95	46 10	02	77 03 034 C61	31 01	02	77 03 052 124	31 40	02	77 03 058 C34	21 30	04
77 03 009 071	52 20	04	77 03 C16 C27	55 20	05	77 03 034 C62	31 01	04	77 03 052 136	32 01	08	77 03 058 C34	21 30	12
77 03 015 015	87 30	01	77 03 C16 C27	55 20	06	77 03 034 C67	31 30	02	77 03 052 142	21 40	01	77 03 C61 013	17 01	01
77 03 016 007	81 40	01	77 03 C19 C05	38 20	02	77 03 040 001	21 40	01	77 03 052 144	21 40	01	77 03 C61 C14	11 20	02
77 03 016 008	12 30	01	77 03 C19 C14	38 01	02	77 03 041 003	13 20	04	77 03 052 145	80 30	06	77 03 C61 C16	21 40	02
77 03 016 008	50 15	02	77 03 C19 C14	38 01	03	77 03 041 007	46 10	01	77 03 052 C02	32 30	04	77 03 C62 C01	34 30	01
77 03 016 010	76 01	02	77 03 C19 C14	41 30	04	77 03 044 003	37 70	04	77 03 052 C02	34 30	04	77 03 C62 C01	37 80	02
77 03 016 010	77 10	04	77 03 C19 C17	55 01	02	77 03 044 006	84 01	01	77 03 052 C02	17 01	02	77 03 C62 C01	37 80	04
77 03 016 010	84 20	04	77 03 C19 C31	60 20	03	77 03 044 008	61 10	02	77 03 052 C07	12 45	02	77 03 C62 C01	37 90	02
77 03 016 017	50 40	02	77 03 C19 C31	60 50	03	77 03 044 008	61 10	04	77 03 052 C09	37 10	01	77 03 C62 C01	37 90	04
77 03 016 020	19 30	03	77 03 C19 C32	60 50	03	77 03 044 008	72 01	02	77 03 052 C09	37 40	02	77 03 C62 C03	23 20	01
77 03 016 020	87 30	01	77 03 C19 C38	55 10	02	77 03 044 014	72 01	04	77 03 052 C10	16 30	01	77 03 C62 C03	23 20	02

1	2	3	1	2	3	1	2	3	1	2	3	1	2	3
77 03 065 C11	23 20	C1	77 C3 072 C25	58 01	XX	77 03 078 033	55 20	C2	77 C3 090 052	21 40	C1	79 CC CCC 673	10 10	C1
77 03 065 012	23 20	02	77 03 072 038	19 40	02	77 03 079 027	90 30	02	77 03 090 054	21 40	01	79 00 00C 680	11 40	02
77 03 065 013	22 20	02	77 C3 072 042	69 01	04	77 03 079 032	90 30	XX	77 C3 090 058	26 20	C1	79 CC CCC 681	11 40	02
77 03 065 015	87 50	01	77 03 072 043	34 10	02	77 03 079 033	90 30	C2	77 03 090 059	21 40	02	79 01 010 597	10 40	01
77 03 065 020	87 50	01	77 03 072 043	46 10	04	77 03 079 037	90 30	07	77 03 090 058	23 40	C2	79 01 011 055	10 60	06
77 03 065 032	23 20	01	77 03 072 043	61 30	02	77 03 079 051	90 30	02	77 03 090 115	10 60	01	79 01 011 321	10 30	C1
77 03 065 037	87 50	C2	77 C3 072 043	61 30	07	77 03 079 051	90 30	05	77 03 090 116	26 30	02	79 01 011 871	10 30	C1
77 03 065 053	21 50	01	77 03 072 043	80 10	16	77 03 079 052	90 30	01	77 03 090 118	26 30	02	79 01 020 209	11 20	C1
77 03 065 054	21 50	02	77 C3 072 044	61 01	02	77 03 079 053	90 30	03	77 03 097 012	50 55	XX	79 01 020 211	11 20	C1
77 03 065 055	21 50	01	77 03 072 050	19 50	04	77 03 079 055	90 30	02	77 03 097 013	50 55	XX	79 01 060 155	10 60	06
77 03 065 056	21 40	01	77 03 072 050	19 60	12	77 03 080 000	76 01	02	77 03 097 019	50 55	XX	79 01 060 645	10 30	C1
77 03 066 003	36 20	01	77 03 072 050	37 30	02	77 03 080 012	38 30	02	77 03 097 020	50 55	XX	79 01 060 724	10 60	12
77 03 066 026	36 20	C1	77 C3 072 052	56 10	04	77 03 083 001	90 40	XX	77 C3 097 026	50 55	XX	79 01 060 725	10 60	12
77 03 066 039	38 20	01	77 03 072 104	57 01	04	77 03 083 002	90 40	XX	77 03 097 028	88 20	XX	79 01 064 031	10 60	06
77 03 066 080	38 20	02	77 03 072 104	57 10	04	77 03 083 019	12 01	C1	77 C3 097 044	88 20	XX	79 01 084 907	11 30	C2
77 03 066 087	29 01	01	77 03 073 010	90 10	XX	77 03 083 019	90 40	02	77 03 097 047	50 55	XX	79 01 090 330	11 30	12
77 03 066 137	38 20	01	77 03 073 030	90 10	01	77 03 083 019	90 40	04	77 03 097 050	88 20	XX	79 01 100 126	10 70	C1
77 03 066 150	38 01	01	77 C3 073 034	90 15	XX	77 03 083 033	12 01	C1	77 03 097 057	90 50	XX	79 01 120 708	11 01	C1
77 03 066 150	52 20	01	77 03 074 005	90 15	02	77 03 083 033	90 40	C1	77 03 097 068	88 20	XX	79 02 101 348	11 20	06
77 03 066 151	85 01	05	77 03 074 022	72 01	16	77 03 083 033	90 40	C4	77 03 097 054	88 20	XX	79 02 101 349	11 20	C6
77 03 066 151	85 10	05	77 03 074 022	72 01	18	77 03 083 045	11 01	C2	77 03 097 055	88 20	XX	79 02 101 351	11 20	06
77 03 066 153	37 30	01	77 03 074 034	90 15	04	77 03 083 049	60 20	01	77 03 097 056	88 20	XX	79 02 101 352	11 20	C6
77 03 066 153	38 01	01	77 03 074 035	90 15	02	77 03 083 050	90 40	XX	78 02 188 000	10 60	01	79 02 101 354	11 20	12
77 03 066 153	52 20	01	77 03 074 037	90 15	04	77 03 083 054	90 40	XX	78 02 122 000	10 40	C1	79 02 101 355	11 20	12
77 03 066 153	52 20	02	77 03 074 037	90 15	08	77 03 083 058	90 40	C1	78 05 074 000	11 20	C2	79 02 101 374	10 30	01
77 03 066 153	76 01	01	77 03 075 015	10 40	01	77 03 083 059	90 40	XX	78 05 093 000	12 50	01	79 02 101 375	10 30	01
77 03 066 154	37 30	01	77 C3 075 015	10 50	01	77 03 084 001	36 20	C2	78 10 143 000	11 01	01	79 02 101 376	10 30	C1
77 03 066 154	52 20	02	77 03 075 016	11 40	01	77 03 084 002	36 20	02	78 10 143 000	11 20	01	79 02 101 377	10 30	01
77 03 066 154	85 20	01	77 03 075 020	23 20	01	77 03 085 004	90 35	XX	78 12 050 000	11 30	12	79 02 101 378	10 30	C1
77 03 066 157	21 60	01	77 03 076 018	78 10	02	77 03 085 005	90 35	XX	78 12 075 000	11 40	24	79 03 001 003	37 30	02
77 03 066 205	21 40	01	77 03 076 018	78 10	10	77 03 085 006	90 35	XX	78 12 080 000	11 40	12	79 03 001 011	52 20	C2
77 03 066 209	21 40	01	77 03 076 018	78 10	20	77 03 085 055	21 20	02	78 12 103 000	11 20	06	79 03 001 014	52 01	C4
77 03 066 214	21 40	C1	77 C3 076 018	78 10	28	77 03 087 012	21 40	01	78 12 116 000	11 40	12	79 03 001 037	61 30	C3
77 03 066 215	21 50	01	77 03 076 022	66 01	14	77 03 087 013	21 40	C1	78 13 025 000	12 01	01	79 03 001 040	19 01	C2
77 03 067 023	29 01	02	77 03 076 027	72 01	16	77 03 087 019	11 20	C1	78 30 051 000	23 20	02	79 03 001 051	58 01	C2
77 03 067 039	21 20	02	77 03 076 027	72 01	18	77 03 087 021	21 50	02	78 30 099 000	10 40	01	79 03 001 064	84 01	02
77 03 067 040	21 50	02	77 03 076 033	60 20	06	77 03 087 021	23 20	C2	78 53 127 000	34 01	01	79 03 001 074	56 40	C4
77 03 067 042	11 30	02	77 03 076 034	81 40	01	77 03 087 027	23 20	C1	78 66 037 000	37 20	C2	79 03 001 074	58 01	01
77 03 067 135	29 01	C2	77 C3 076 041	46 10	01	77 03 087 035	10 40	C1	78 66 038 000	37 20	C2	79 03 001 077	80 10	02
77 03 067 136	38 30	01	77 03 076 043	55 20	06	77 03 088 001	57 01	C2	78 66 040 000	37 20	02	79 03 001 077	81 10	02
77 03 067 136	38 30	02	77 03 077 018	55 20	10	77 03 088 001	57 10	C2	78 67 065 000	38 01	C1	79 03 001 080	36 20	C2
77 03 067 138	53 01	C3	77 C3 077 024	55 20	10	77 03 088 003	41 10	02	79 00 000 658	11 01	01	79 03 001 058	13 01	02
77 03 067 140	50 01	C2	77 03 077 025	55 20	26	77 03 088 004	68 01	01	79 00 000 662	12 01	01	79 03 001 344	12 45	C1
77 03 067 141	50 01	04	77 03 077 025	19 01	02	77 03 088 014	19 60	01	79 00 000 663	12 01	01	79 03 001 366	11 30	C2
77 03 067 156	38 30	01	77 03 078 016	90 20	XX	77 03 090 030	21 40	C2	79 00 000 664	12 01	01	79 03 001 367	11 40	02
77 03 068 002	37 20	01	77 03 078 021	90 25	XX	77 03 090 031	21 40	C2	79 00 000 665	10 01	C1	79 03 001 368	11 30	02
77 03 068 002	37 60	01	77 03 078 023	90 20	XX	77 03 090 050	21 50	02	79 00 000 670	10 10	01	79 03 005 057	11 20	20
77 03 068 002	38 01	01	77 03 078 030	71 01	01	77 03 090 052	21 40	01	79 00 000 672	10 10	01	79 03 027 002	12 01	C4

1	2	3	1	2	3	1	2	3	1	2	3	1	2	3
79 03 027 059	11 20	06	79 03 032 01E	19 30	01	79 03 044 014	61 30	03	79 03 053 052	52 01	06	79 03 056 012	21 30	06
79 03 027 065	13 20	06	79 03 032 01E	19 50	01	79 03 046 002	55 20	02	79 03 053 061	21 01	04	79 03 056 012	75 01	08
79 03 027 067	12 01	03	79 03 032 01E	19 50	03	79 03 053 020	17 01	02	79 03 053 061	32 10	04	79 03 056 014	19 50	01
79 03 027 068	12 01	02	79 03 032 01E	19 60	04	79 03 053 020	85 20	03	79 03 053 065	12 70	01	79 03 056 014	31 40	06
79 03 027 069	10 40	0E	79 03 032 01E	19 80	06	79 03 053 024	23 20	01	79 03 053 067	36 20	02	79 03 056 014	36 20	04
79 02 032 003	81 40	01	79 03 032 01E	32 10	04	79 03 053 025	16 20	05	79 03 053 077	13 50	01	79 03 056 014	41 30	04
79 03 032 003	86 20	01	79 03 032 01E	34 10	04	79 03 053 025	72 01	02	79 03 053 095	11 40	12	79 03 056 014	72 01	04
79 03 032 006	12 70	01	79 03 032 01E	37 01	04	79 03 053 025	85 01	02	79 03 053 114	31 01	02	79 03 056 014	76 01	02
79 03 032 006	16 10	02	79 03 032 01E	37 10	04	79 03 053 025	85 10	02	79 03 053 125	46 10	01	79 03 056 014	82 01	01
79 03 032 006	16 16	03	79 03 032 01E	52 20	02	79 03 053 026	37 20	01	79 03 053 157	19 50	04	79 03 056 017	41 10	04
79 03 032 006	16 20	05	79 03 032 01E	55 01	02	79 03 053 026	37 20	02	79 03 053 157	41 10	06	79 03 056 017	41 30	02
79 03 032 006	55 10	18	79 03 032 01E	55 01	04	79 03 053 026	37 70	01	79 03 053 157	60 20	03	79 03 056 021	87 40	02
79 03 032 006	80 10	02	79 03 032 01E	55 10	02	79 03 053 028	11 30	04	79 03 053 162	36 20	01	79 03 056 027	17 10	03
79 03 032 006	81 10	02	79 03 032 01E	57 01	04	79 03 053 028	13 20	04	79 03 053 162	36 30	02	79 03 056 027	46 10	02
79 02 032 006	81 10	06	79 03 032 01E	57 10	04	79 03 053 028	37 30	01	79 03 053 164	11 30	16	79 03 056 027	46 10	03
79 03 032 006	84 01	01	79 03 032 01E	80 01	01	79 03 053 028	37 70	04	79 03 053 215	37 20	02	79 03 056 027	58 30	02
79 03 032 006	85 01	02	79 03 032 021	33 40	06	79 03 053 028	38 01	01	79 03 053 265	10 50	08	79 03 056 030	19 80	04
79 03 032 006	85 10	02	79 03 032 022	50 01	04	79 03 053 031	13 20	02	79 03 055 002	33 40	08	79 03 056 030	52 20	02
79 03 032 006	87 01	02	79 03 032 022	50 01	06	79 03 053 031	46 10	01	79 03 056 003	17 01	02	79 03 056 030	57 01	04
79 03 032 006	88 20	02	79 03 032 023	11 01	01	79 03 053 035	46 01	08	79 03 056 003	64 10	01	79 03 056 030	57 10	04
79 03 032 008	15 01	01	79 03 032 023	13 90	02	79 03 053 035	46 01	18	79 03 056 003	64 20	01	79 03 056 035	55 20	02
79 03 032 008	85 01	02	79 03 032 023	13 90	03	79 03 053 035	46 10	03	79 03 056 003	67 30	01	79 03 056 035	57 30	03
79 03 032 008	85 10	02	79 03 032 023	16 30	01	79 03 053 036	38 01	01	79 03 056 005	16 10	02	79 03 056 035	68 01	08
79 03 032 009	11 01	04	79 03 032 023	41 30	02	79 03 053 039	11 20	02	79 03 056 005	16 16	03	79 03 056 035	81 40	01
79 03 032 009	13 20	06	79 03 032 023	52 01	02	79 03 053 039	16 20	02	79 03 056 005	33 40	02	79 03 056 036	16 30	02
79 03 032 009	16 10	02	79 03 032 036	12 45	03	79 03 053 041	38 01	02	79 03 056 005	80 10	02	79 03 056 036	50 15	02
79 03 032 009	17 10	03	79 03 032 055	85 01	02	79 03 053 041	41 30	04	79 03 056 005	61 10	02	79 03 056 036	50 25	02
79 03 032 009	19 01	04	79 03 032 055	85 10	02	79 03 053 043	12 01	02	79 03 056 005	61 10	06	79 03 056 036	55 10	18
79 03 032 009	37 30	02	79 03 032 070	16 16	03	79 03 053 043	19 50	01	79 03 056 005	64 01	01	79 03 056 036	61 10	04
79 02 032 009	37 70	01	79 03 032 070	85 01	01	79 03 053 043	19 50	04	79 03 056 005	64 01	04	79 03 056 036	86 01	02
79 03 032 009	41 30	02	79 03 032 070	85 10	01	79 03 053 043	19 50	07	79 03 056 005	65 01	02	79 03 056 037	45 01	06
79 03 032 009	50 60	03	79 03 032 072	37 30	01	79 03 053 043	19 60	03	79 03 056 005	65 10	02	79 03 056 037	50 60	03
79 03 032 009	76 01	02	79 03 032 072	38 01	01	79 03 053 043	19 60	12	79 03 056 005	67 01	02	79 03 056 039	13 20	04
79 03 032 009	76 01	04	79 03 032 074	36 30	01	79 03 053 043	36 20	01	79 03 056 005	68 20	02	79 03 056 039	19 01	04
79 03 032 012	11 01	01	79 03 032 100	38 01	01	79 03 053 043	37 01	01	79 03 056 007	19 01	01	79 03 056 039	31 40	04
79 03 032 012	11 20	02	79 03 032 123	11 30	12	79 03 053 043	37 10	01	79 03 056 007	16 10	02	79 03 056 039	41 30	02
79 03 032 012	12 30	02	79 03 032 124	12 10	02	79 03 053 043	38 01	02	79 03 056 007	16 16	03	79 03 056 039	57 01	02
79 03 032 012	16 20	01	79 03 032 160	12 01	12	79 03 053 045	16 30	01	79 03 056 008	33 40	04	79 03 056 039	57 10	02
79 03 032 012	37 10	01	79 03 032 161	10 50	08	79 03 053 046	13 80	01	79 03 056 008	37 30	02	79 03 056 039	76 01	02
79 03 032 012	37 20	01	79 03 034 007	36 30	02	79 03 053 048	52 20	04	79 03 056 008	41 30	02	79 03 056 040	16 30	01
79 03 032 012	37 20	02	79 03 037 001	50 60	12	79 03 053 050	13 80	01	79 03 056 008	75 01	08	79 03 056 040	38 20	04
79 03 032 012	37 40	02	79 03 037 001	50 70	02	79 03 053 050	19 80	02	79 03 056 008	76 01	02	79 03 056 040	72 01	04
79 03 032 012	38 30	02	79 03 037 001	52 20	02	79 03 053 050	31 01	02	79 03 056 008	76 01	04	79 03 056 042	23 20	01
79 03 032 012	38 30	08	79 03 037 002	52 20	02	79 03 053 050	33 01	04	79 03 056 008	65 01	01	79 03 056 042	37 20	02
79 03 032 013	17 01	01	79 03 037 002	52 20	08	79 03 053 050	33 01	06	79 03 056 008	65 01	02	79 03 056 042	37 70	02
79 03 032 016	76 01	02	79 03 037 006	50 30	02	79 03 053 050	41 10	01	79 03 056 008	65 10	01	79 03 056 042	37 70	04
79 03 032 018	12 01	02	79 03 039 005	11 01	01	79 03 053 050	41 10	04	79 03 056 008	65 10	03	79 03 056 042	38 01	02
79 03 032 018	16 30	01	79 03 044 014	58 30	02	79 03 053 052	41 30	02	79 03 056 011	38 30	02	79 03 056 045	19 30	05

1	2	3	1	2	3	1	2	3	1	2	3	1	2	3
79 03 056 045	19 80	02	79 03 C57 013	11 40	02	79 10 009 518	13 50	C1	79 10 245 162	11 30	C4	79 10 245 554	17 10	C1
79 03 056 045	19 80	04	79 03 057 033	37 C1	01	79 10 011 595	12 01	C1	79 10 245 163	11 30	C4	79 10 245 558	97 01	C1
79 03 056 045	38 C1	02	79 03 C57 044	10 40	05	79 10 011 862	37 20	C1	79 10 245 165	12 70	C1	79 10 245 607	13 30	C1
79 03 056 045	55 C1	02	79 03 062 001	10 40	03	79 10 013 828	17 10	02	79 10 245 205	11 40	C1	79 10 245 655	11 20	C1
79 03 056 045	55 C1	04	79 03 062 001	17 10	01	79 10 013 829	13 30	C1	79 10 245 207	10 60	C1	79 10 245 656	11 20	C1
79 03 056 045	55 10	02	79 03 C62 003	10 40	03	79 10 016 365	34 01	01	79 10 245 208	10 60	C1	79 10 245 661	13 50	C1
79 03 056 046	38 C1	01	79 03 C62 003	10 50	01	79 10 016 472	36 20	01	79 10 245 217	12 45	C1	79 10 245 662	12 01	C1
79 03 056 046	85 01	02	79 03 062 003	23 20	02	79 10 016 928	36 20	C1	79 10 245 242	12 C1	C1	79 10 245 670	12 10	C1
79 03 056 046	85 10	02	79 03 062 003	23 30	01	79 10 017 090	36 20	C1	79 10 245 243	11 20	C1	79 10 245 671	12 15	C1
79 03 056 047	19 80	04	79 03 C62 020	10 40	01	79 10 017 459	34 01	02	79 10 245 244	11 20	C3	79 10 245 672	12 45	C1
79 03 056 048	59 20	02	79 03 C65 007	11 40	01	79 10 017 469	34 01	C1	79 10 245 260	10 40	C6	79 10 245 673	12 45	C1
79 03 056 048	59 20	02	79 03 C65 007	11 40	01	79 10 017 469	34 01	C1	79 10 245 260	10 40	C6	79 10 245 673	12 45	C1
79 03 056 048	59 20	02	79 03 C65 007	11 40	01	79 10 017 469	34 01	C1	79 10 245 260	10 40	C6	79 10 245 673	12 45	C1
79 02 056 067	38 01	02	79 03 C65 007	34 01	01	79 10 017 476	34 01	01	79 10 245 261	10 40	C6	79 10 245 685	13 10	C1
79 03 056 067	82 01	02	79 03 C65 015	11 01	02	79 10 017 653	11 C1	C1	79 10 245 262	10 40	C6	79 10 245 686	12 50	C1
79 03 056 068	41 10	02	79 03 C65 030	13 20	01	79 10 017 708	32 01	C2	79 10 245 263	10 40	C6	79 10 245 691	13 50	C1
79 03 057 001	10 70	03	79 03 C65 057	10 40	01	79 10 245 014	12 45	C2	79 10 245 278	11 C1	C1	79 10 245 696	12 70	C1
79 03 057 001	11 30	02	79 03 C65 057	10 70	01	79 10 245 031	11 30	C2	79 10 245 286	11 20	C1	79 10 245 703	17 10	C6
79 03 057 001	11 30	04	79 03 066 014	11 30	02	79 10 245 034	11 30	C2	79 10 245 291	11 20	C1	79 10 245 706	13 01	C1
79 03 057 002	10 70	03	79 03 C67 005	21 40	01	79 10 245 039	12 70	C1	79 10 245 301	11 20	C2	79 10 245 708	12 45	C1
79 03 057 002	10 70	04	79 03 C67 009	10 40	04	79 10 245 055	11 30	C6	79 10 245 305	11 20	C1	79 10 245 720	17 01	C1
79 03 057 002	11 30	C2	79 03 067 012	11 20	04	79 10 245 056	11 30	C2	79 10 245 307	11 20	C1	79 10 245 723	13 50	C1
79 03 057 003	10 50	01	79 03 C67 014	11 30	04	79 10 245 057	11 01	C1	79 10 245 307	10 40	C1	79 10 245 724	13 50	C2
79 03 057 003	10 50	02	79 03 C67 023	10 40	01	79 10 245 060	13 20	C1	79 10 245 308	10 40	C1	79 10 245 725	13 50	C1
79 03 057 003	11 C1	01	79 03 C67 023	10 40	02	79 10 245 061	10 70	C1	79 10 245 370	11 30	C2	79 10 245 731	12 50	C1
79 03 057 003	11 C1	02	79 03 C67 052	10 60	03	79 10 245 065	11 01	C1	79 10 245 407	12 01	C1	79 10 245 738	11 01	C1
79 03 057 003	11 C1	04	79 03 C68 001	12 70	01	79 10 245 068	11 01	C2	79 10 245 405	12 50	C1	79 10 245 766	10 60	C1
79 03 057 003	11 C1	05	79 03 C68 009	10 70	01	79 10 245 069	11 01	C2	79 10 245 412	11 30	C1	79 40 009 120	10 60	C6
79 03 057 003	11 40	02	79 03 C70 004	11 01	01	79 10 245 070	11 20	C1	79 10 245 431	11 40	C1	79 40 009 146	10 50	C1
79 03 057 003	11 40	25	79 03 070 005	10 60	02	79 10 245 073	11 30	C2	79 10 245 464	12 50	C1	79 43 010 004	36 30	C1
79 03 057 003	12 C1	04	79 03 C73 018	90 10	02	79 10 245 074	11 30	C6	79 10 245 465	12 50	C1	79 43 010 011	36 20	C1
79 03 057 003	12 45	02	79 03 C74 053	64 C1	02	79 10 245 075	12 01	C1	79 10 245 472	12 70	C1	79 46 000 030	17 10	C1
79 03 057 003	12 45	04	79 03 075 003	11 20	01	79 10 245 079	11 20	C2	79 10 245 473	12 70	C1	80 70 040 082	17 C1	C2
79 03 057 003	12 70	C1	79 03 075 015	12 01	01	79 10 245 081	10 40	C1	79 10 245 474	12 70	C1	80 70 040 082	16 16	C1
79 03 057 003	12 70	02	79 03 075 019	11 20	03	79 10 245 082	11 30	C2	79 10 245 507	11 01	C1	80 70 040 082	85 20	C3
79 03 057 003	13 C1	02	79 03 075 021	12 01	02	79 10 245 083	11 30	16	79 10 245 505	11 C1	C1	80 70 040 122	17 C1	C2
79 03 057 003	13 30	02	79 03 075 027	10 40	02	79 10 245 088	10 60	01	79 10 245 538	13 50	C1			
79 03 057 003	13 50	01	79 03 075 028	10 40	01	79 10 245 090	13 01	C1	79 10 245 548	11 30	C1			
79 03 057 003	17 C1	01	79 03 075 033	10 40	01	79 10 245 095	11 01	C1	79 10 245 551	17 10	C1			
79 03 057 003	38 20	02	79 03 075 033	10 50	01	79 10 245 098	13 50	01	79 10 245 555	12 70	C1			
79 03 057 003	87 50	02	79 03 C75 033	23 30	01	79 10 245 102	12 01	C2	79 10 245 556	12 70	C1			
79 03 057 005	10 50	12	79 03 076 039	90 20	XX	79 10 245 106	11 30	C8	79 10 245 557	12 70	C2			
79 03 057 005	11 C1	03	79 03 C83 047	50 40	01	79 10 245 107	11 20	20	79 10 245 558	12 C1	C1			
79 03 057 005	11 20	04	79 03 C83 075	13 30	01	79 10 245 110	10 60	01	79 10 245 559	10 60	C1			
79 03 057 005	12 10	02	79 03 C87 C19	11 40	01	79 10 245 144	11 30	C1	79 10 245 573	10 70	C1			
79 03 057 005	13 30	01	79 10 004 062	10 70	01	79 10 245 145	10 40	01	79 10 245 582	11 40	C1			
79 03 057 005	16 30	01	79 10 004 065	11 30	02	79 10 245 154	10 70	01	79 10 245 584	11 40	C1			
79 03 057 009	21 60	01	79 10 004 173	34 01	01	79 10 245 158	11 01	C2	79 10 245 585	11 20	C1			
79 03 057 013	11 C1	04	79 10 007 584	36 20	01	79 10 245 159	11 30	C2	79 10 245 585	12 10	C2			
79 03 057 013	11 20	02	79 10 009 147	13 10	01	79 10 245 160	11 30	C2	79 10 245 593	17 10	C6			



<p style="text-align: center;">FRANÇAIS</p> <p>Tous les droits d'auteur sont réservés à la Régie Nationale des Usines Renault. La reproduction ou la traduction même partielle du présent catalogue ainsi que l'utilisation du système de numérotage de référence des pièces de rechange sont interdites sans l'autorisation écrite et préalable de la Régie Nationale des Usines Renault.</p> <p>© Régie Nationale des Usines RENAULT 1975</p>	<p style="text-align: center;">DANSK</p> <p>Alle ophavsrettigheder tilhører Régie Nationale des Usines Renault. Gengivelse eller oversættelse, også i uddrag, af dette katalog samt anvendelse af reservedelens nummereringssystem er ikke tilladt uden skriftlig tilladelse fra Régie Nationale des Usines Renault.</p> <p>© Régie Nationale des Usines RENAULT 1975</p>	<p style="text-align: center;">DEUTSCH</p> <p>Sämtliche Urheberrechte liegen bei der Régie Nationale des Usines Renault. Nachdruck oder Übersetzung, selbst auszugsweise, des vorliegenden Kataloges sowie die Verwendung der Ersatzteilnummern und des Numerierungssystems sind nicht gestattet ohne besondere schriftliche Genehmigung der Régie Nationale des Usines Renault.</p> <p>© Régie Nationale des Usines RENAULT 1975</p>
<p style="text-align: center;">ENGLISH</p> <p>All copyrights reserved by the Régie Nationale des Usines Renault. Copying or translation, in part or in full of this catalogue or use of the spare part reference numerotation system is forbidden without the prior written authority of the Régie Nationale des Usines Renault.</p> <p>© Régie Nationale des Usines RENAULT 1975</p>	<p style="text-align: center;">ESPAÑOL</p> <p>La Régie Nationale des Usines Renault se reserva todos los derechos de autor. Queda prohibida la reproducción, o la traducción, incluso parcial, del presente catálogo, así como la utilización del sistema de numeración de referencia de las piezas de repuesto, sin la autorización por escrito de la Régie Nationale des Usines Renault.</p> <p>© Régie Nationale des Usines RENAULT 1975</p>	<p style="text-align: center;">ITALIANO</p> <p>Tutti i diritti d'autore sono riservati alla Régie Nationale des Usines Renault. La riproduzione o la traduzione anche parziali del presente catalogo come pure l'utilizzazione del sistema di numerazione di riferimento delle parti di ricambio sono vietate senza previa autorizzazione scritta della Régie Nationale des Usines Renault.</p> <p>© Régie Nationale des Usines RENAULT 1975</p>
<p style="text-align: center;">NEDERLANDS</p> <p>Alle auteursrechten zijn voorbehouden aan de Régie Nationale des Usines Renault. Reproducieren en/of vertalen, zelfs gedeeltelijk, van deze catalogus evenals het overnemen van indeling van dit boek en/of wijze van aanduiding der onderdelen is verboden zonder vooraf ontvangen schriftelijke goedkeuring van de Régie Nationale des Usines Renault.</p> <p>© Régie Nationale des Usines RENAULT 1975</p>		<p style="text-align: center;">SVENSKA</p> <p>Samtliga rättigheter förbehålls oinskränkta Régie Nationale des Usines Renault. Eftertryck eller delvis översättning av denna reservdelskatalog samt användning av referenssystemet för numrering av reservdelar är förbjudna utan skriftligt tillstånd från Régie Nationale des Usines Renault.</p> <p>© Régie Nationale des Usines RENAULT 1975</p>

Dessins originaux exécutés par la Régie Nationale des Usines Renault, Bord, Burotec, D.T.R.B., Editechnic, Filloux, I.T.E. Sofrème
 Originaltegninger udarbejdet af Régie Nationale des Usines Renault, Bord, Burotec, D.T.R.B., Editechnic, Filloux, I.T.E. Sofrème
 Original-Zeichnungen der Régie Nationale des Usines Renault, Bord, Burotec, D.T.R.B., Editechnic, Filloux, I.T.E. Sofrème
 Original drawings prepared by the Régie Nationale des Usines Renault, Bord, Burotec, D.T.R.B., Editechnic, Filloux, I.T.E. Sofrème
 Dibujos originales ejecutados por la Régie Nationale des Usines Renault, Bord, Burotec, D.T.R.B., Editechnic, Filloux, I.T.E. Sofrème
 Disegni originali eseguiti dalla Régie Nationale des Usines Renault, Bord, Burotec, D.T.R.B., Editechnic, Filloux, I.T.E. Sofrème
 Originale tekening door Régie Nationale des Usines Renault, Bord, Burotec, D.T.R.B., Editechnic, Filloux, I.T.E. Sofrème
 Originalritningar utförda av Régie Nationale des Usines Renault, Bord, Burotec, D.T.R.B., Editechnic, Filloux, I.T.E. Sofrème

Der Franzose